

School District 69 Qualicum – Strategic Energy Management Proposal in partnership with BC Hydro

Site	Size in square feet	Year built	Area	Hydro Grant	SD69 Responsibility	Cost per ft2
Ballenas Secondary School	117143	1996-2001	Parksville	\$17,685.00	\$29,286.00	\$0.25/ft2
Kwalikum Secondary School	105206.5	1981-1987	Qualicum Beach	\$15,895.00	\$26,300.00	\$0.25/ft2
Oceanside Elementary School	61694.54	1993	Parksville	\$9,368.00	\$15,524.00	\$0.25/ft2
Springwood Elementary School	56693.52	1996	Parksville	\$8,618.00	\$14,173.00	\$0.25/ft2
Qualicum Elementary School	53119.9	2002	Qualicum Beach	\$8,082.00	\$13,280.00	\$0.25/ft2
<b>Total</b>	<b>393857.46 ft2</b>			<b>\$59,648.00</b>	<b>\$98,563.00</b>	

School District 69 in partnership with Prism Engineering applied to BC Hydro to obtain a Continuous Optimization Program Grant to use towards our Proposal for Strategic Energy Management.

Shown above are the costs associated with both parts of the proposal. BC Hydro has authorized grant amounts to sites in the amount of approx. \$0.15/ft2, but associated with the grant, SD69 will be responsible to pay (over a 2-year period) an amount equal to \$0.25/ft2 in energy related reductions from the Prism Engineering Strategic Plan audit. The totals associated to this (see above under SD69 Responsibilities) will be an expectation under the “BC Hydro Incentive Project Summary and Applicants Project Implementation Declaration” which is a signed contract with BC Hydro.

Respectfully submitted by Chris Dempster

Continuous Optimization for Commercial Buildings Program

# Recommissioning Report

---

Version	Updated on	Phase
1	May 10, 2022	Investigation. Draft for client feedback.

Prepared for:

School District 69

Oceanside Elementary School

980 Wright Rd

Qualicum Beach, BC

Project: BCH-07834

Prism Project: 2021300

---

Prepared by:

Prism Engineering Ltd.

#320 - 3605 Gilmore Way

Burnaby, BC



# TABLE OF CONTENTS

<b>1.0</b>	<b>INTRODUCTION</b> .....	<b>3</b>
<b>2.0</b>	<b>PROJECT OVERVIEW</b> .....	<b>4</b>
<b>3.0</b>	<b>SAVINGS SUMMARY</b> .....	<b>5</b>
<b>4.0</b>	<b>BRIEF DESCRIPTION OF EXISTING SYSTEM</b> .....	<b>6</b>
4.1	FACILITY DESCRIPTION .....	6
4.2	HEATING SYSTEM .....	7
4.3	COOLING SYSTEM .....	9
4.4	VENTILATION SYSTEM .....	9
4.5	DOMESTIC HOT WATER SYSTEM .....	11
4.6	CONTROLS SYSTEM .....	11
4.7	OTHER EQUIPMENT .....	11
<b>5.0</b>	<b>MEASURES SELECTED FOR IMPLEMENTATION (UNDER C.OP. PROGRAM)</b> .....	<b>12</b>
5.1	NEW MEASURES .....	12
<b>6.0</b>	<b>MEASURES TO BE CONSIDERED FOR FUTURE IMPLEMENTATION</b> .....	<b>28</b>
6.1	MEASURE 12: ADD REVERSIBLE HEAT PUMP TO BOILER LOOP .....	28
<b>7.0</b>	<b>NEXT STEPS – IMPLEMENTATION PHASE AND COMPLETION PHASE</b> .....	<b>30</b>
7.1	IMPLEMENTATION PHASE .....	30
7.2	COMPLETION PHASE .....	30
<b>APPENDIX A:</b>	<b> INVESTIGATION PHASE SUMMARY TABLE</b> .....	<b>32</b>
<b>APPENDIX B:</b>	<b> COMPLETION PHASE SUMMARY TABLE</b> .....	<b>33</b>
<b>APPENDIX C:</b>	<b> SAMPLE TRAINING OUTLINE</b> .....	<b>34</b>
<b>APPENDIX D:</b>	<b> TRAINING COMPLETION FORM</b> .....	<b>35</b>

## 1.0 Introduction

Prism Engineering is pleased to present the results of the Investigation Phase that was conducted as part of BC Hydro's Continuous Optimization for Commercial Buildings Program for Oceanside Elementary. The objective of an Investigation is to identify deficiencies and improvements in the operation of a facility's mechanical equipment, lighting, and related controls, and determine opportunities for corrective action that reduce energy consumption and preserve the indoor environmental quality.

This document is a complete record of the work performed at this facility, including the in-depth investigation of the building systems and the implementation of selected measures to optimize building performance.

The Recommissioning Investigation Report provides an overview of the recommendations for the implementation of measures. This information is not considered a specification or detailed sequence of operations. The intent is to provide an overview of the recommendation that can be built upon during the implementation phase as part of any detailed design that may be required. Certain measures may require further investigation and specification for the correct implementation by the owner or the DDC contractor.

Twelve recommended retrofits were identified as a part of this investigation. The proposed measures will be reviewed in a meeting with School District #69 and Prism Engineering representatives to determine which measures will be implemented.

Recommended retrofits for implementation include:

- Measure 1: AC-1 operates continuously
- Measure 2: HV-2 operates continuously
- Measure 3: HV-3 operates continuously
- Measure 4: Air handler schedules
- Measure 5: HV-3 excess ventilation
- Measure 6: Boiler supply setpoint higher when unoccupied
- Measure 7: Night setbacks for reheats and fan coils
- Measure 8: HV-3 occupancy schedule out-of-date
- Measure 9: HV-2 coil issue
- Measure 10: Fan sensor issues
- Measure 11: DHW circulation pump manually on

These measures are presented in the Investigation Summary Table (see Appendix A).

While the investigation focuses on low-cost improvements with short paybacks, some capital improvement opportunities may also be identified. Major retrofit measures are beyond the scope of this program, but other BC Hydro and FortisBC programs provide a variety of incentives to complete the retrofits. Retrofits were identified as a part of this investigation that could potentially qualify for other BC Hydro and FortisBC programs, these measures are described in Section 7.

Retrofits include:

- Measure 12: Add reversible heat pump to boiler loop



## 2.0 Project Overview

Project Information		<i>Complete cells this background colour</i>	
RCx Project File #	<b>BCH-07834</b>		
Date of Workbook Update	10-May-2022		
Organization	School Distict 69		
Building Name	Oceanside Elementary		
Building Type	Large School		
Location (City)	Qualicum Beach, BC		
Owner Contact	Ron Amos		
Investigation Phase start date	01-Feb-2022		
Participated in previous BCH RCx program?	No		
Previous RCx File #			
Previous RCx completion date			
<b>Building Information</b>			
Facility Area (ft <sup>2</sup> )	61,695		
Annual elec consumption (kWh)	233,861	3.8	kWh/ft <sup>2</sup>
Annual elec costs (\$)	\$ 23,071	\$ 0.10	Avg. \$/kWh
Fuel type	Natural Gas		
Annual fuel consumption (GJ)	1,588	7.2	ekWh/ft <sup>2</sup>
Annual fuel cost (\$)	\$ 19,255	\$ 12.1	Avg. \$/GJ
Total GHG emissions (tCO <sub>2</sub> e/yr)	82		
Total Energy Cost	\$ 42,326	\$ 0.69	\$/ft <sup>2</sup>
Energy Use Intensity (ekWh/ft <sup>2</sup> )	10.9		
Year for energy data above	2020		



### 3.0 Savings Summary

Savings Summary	Previous, still working	New + Previous, rectify + Previous, documented					
		Identified		Selected		Implemented	
	# of measures	0	12	11	11		
	Re-claim Savings	Total Savings	% Savings	Total Savings	% Savings	Total Savings	% Savings
Electrical savings (kWh/yr)	-	85,865	36.7%	150,182	64.2%	150,182	64.2%
Fuel savings (GJ/yr)	-	1,558	98.1%	803	50.5%	803	50.5%
Cost savings (\$)	\$ -	\$ 27,359	64.6%	\$ 24,548	58.0%	\$ 24,548	58.0%
GHG reduction (tCO2e/yr)	-	78.6	96.2%	41.6	51.0%	41.6	51.0%
<b># of Abandoned measures</b>	<b>0</b>						



## 4.0 Brief Description of Existing System

This section contains a brief description of the existing HVAC and Controls system. The information is intended to provide a general overview only.

### 4.1 Facility Description

The Oceanside Elementary Schools was built 1993 and has a floor area of 61,695 sqft. The building contains classrooms, admin offices, gym, library, music/drama, and technical teaching spaces.

**Table 1: Schedules**

	Area	Days	From	To
Occupancy	Classrooms	All schooldays	8:45am	2:36pm
	Office hours	All school days	8:00am	3:30pm
Building Equipment	Air Handling Units	Monday-Wednesday	4:00/7:00am*	4:00pm
		Thursday-Friday	7:00am	4:00pm
	Boilers	Monday-Friday	6:30am	6:00pm

\* HV-1, HV-2, HV-3 start at 4am, while other units start at 7am.

Outside occupied hours, air handlers run when required to maintain room temperatures. During occupied hours, boilers are enabled when OAT is below 14°C. Outside these hours they operate when OAT is below 10°C.

Other (zone) equipment, such as reheats and fan coils, do not appear to have any schedules.

Schedules are changed during summer, when the school is mostly unoccupied, and air handlers are only scheduled to flush the school each morning hours.

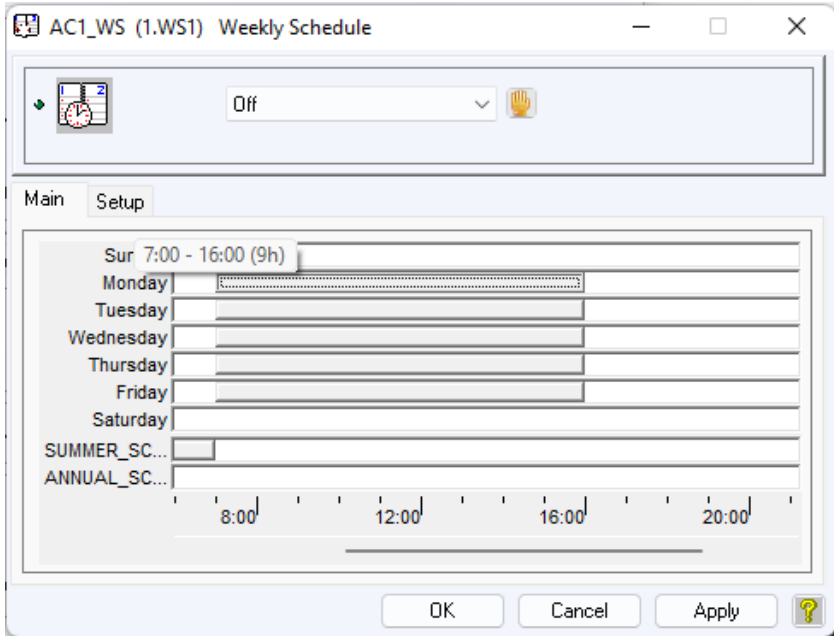
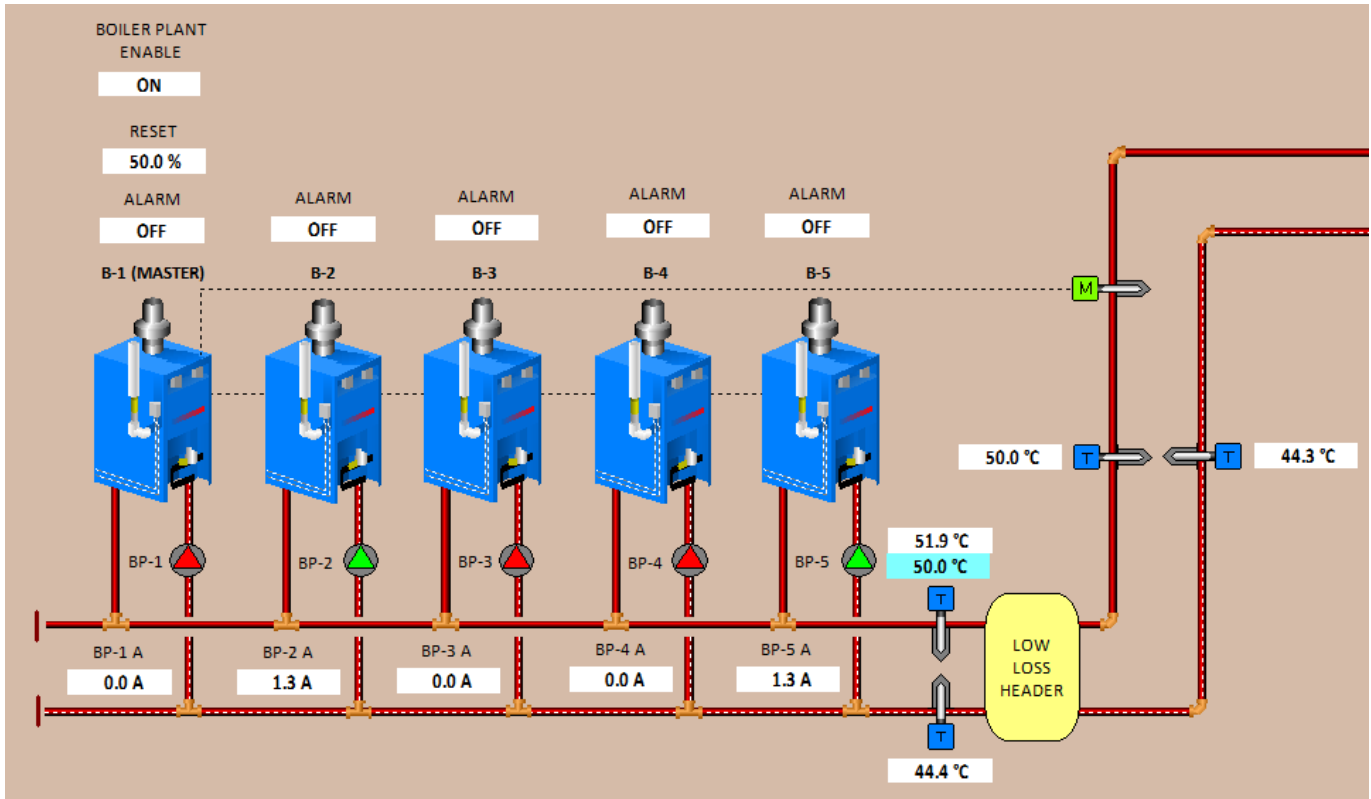

Figure 1: Typical air handler schedule (AC-1)

## 4.2 Heating System

Heating is provided by five 399 MBH (input) IBC condensing gas boilers. Each boiler has its own circulating pump. The primary boiler loop is connected to the secondary loop via a low loss heater. The supply water setpoint for the primary loop has been manually set to 50°C.





**Figure 2: Boilers in the DDC**

Heating water is distributed through a secondary loop to heating coils in AHU-2, AHU-3, and AHU-4, as well as duct reheat coils, fan coil units, unit heaters, and convectors.

**Table 2: Pumps**

Tag	Serves	Size	VSD	Flow	Head (Ft)
BP-1 to BP-5	Boiler pumps	Unknown	No	Unknown	Unknown
P-2	Zone heating coils	3 HP	VSD	10.6 l/s	131.9 Pa
P-3	HV-2	1100 W @ 3.25 A 208 V 3ph	No	0.63 l/s	78.3 Pa
P-4	HV-3	1/3 HP 235 W @ 0.72 A	No	0.95 l/s	68.7 Pa
P-5	DHW circulation	77 W	No	Unknown	Unknown
P-7	Chilled water	3 HP	No	4.48 l/s	186.8 Pa

### 4.3 Cooling System

An air-source chiller serves one hydronic cooling coil in air handling unit AC-1.

Details of the existing chiller have not been made available, but based on AC-1 cooling coil specification, we estimate the chiller capacity is around 25 Tons.

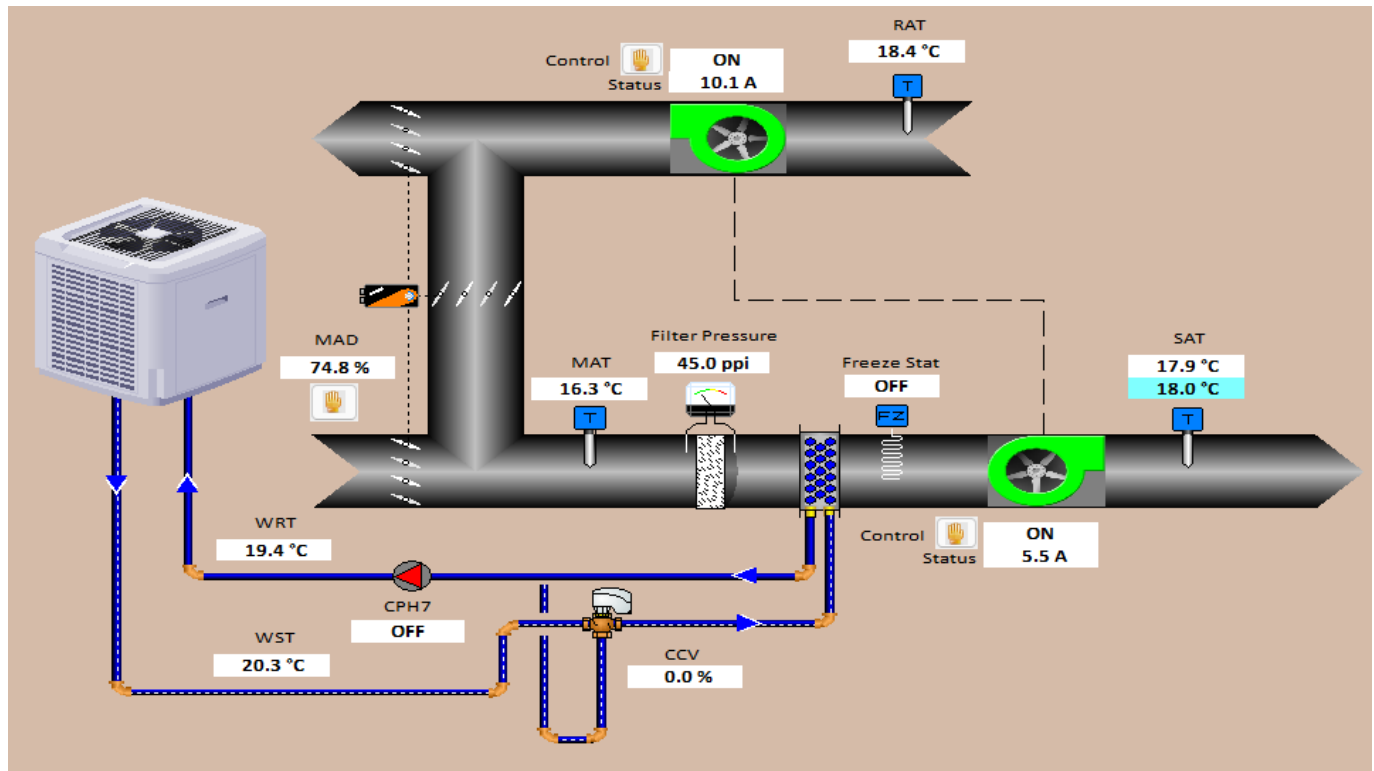

Figure 3: AC-1 and chiller

### 4.4 Ventilation System

Ventilation is provided by the air handlers shown in Table 3. Note that air handlers HV-1 to HV-5 are sometimes referred to as AHU-1 to AHU-5 in the DDC and other documentation.

Table 3: Air handlers

Tag	Service	Airflow	Supply Fan	Return Fan	Coils	Outdoor Air
AC-1	Computer, Tech Lab, Office, Library	5024 l/s	10 HP Constant speed	5 HP	Heating Cooling	Mix

HV-1	Block B. Part of Block C.	7237 l/s	10 HP Constant speed	5 HP	None	Mix
HV-2	Gym	7888 l/s	10 HP VSD	5 HP*	Heating	Mix
HV-3	Block A Classrooms (Main/Upper)	10888 l/s	20 HP Constant speed	7.5 HP Constant	Heating	Mix
HV-4	Construction	944 l/s	1.5 HP Constant speed	N/A	Heating	Mix
HV-5	Boiler room	590 l/s	0.75 HP Constant speed	N/A	None	Mix

\* This fan is listed in the building HVAC documentation, but not shown in the DDC graphics.

Exhaust fans are listed in Table 4.

**Table 4: Exhaust fans**

Tag	Service	Airflow (l/s)	Fan	DDC
EF-A01	Washrooms	1062	½ HP	Not connected
EF-A02	Science	1416	1 HP	Not connected
EF-A03	A104	236	¼ HP	Not connected
EF-A04 EF-A05	Fume Hood Exhaust	330	1 HP	Not connected
EF-A06	A111 Range	94	100 W	Not connected
EF-A07	A130 Range	36	50 W	Not connected
EF-A08	A131 Range	94	100 W	Not connected
EF-B01	B107 Range	94	100 W	Not connected
EF-C01	Gym Dressing	813	½ HP	

EF-C02	B119, B120	376	¼ HP	Controlled
EF-C03	C106	708	½ HP	Controlled
EF C04	C107	708	¾ HP	Controlled
EF-C05	C107 Kiln	472	½ HP	Controlled
EF-C06	C107 Cer	472	½ HP	Controlled
EF-C07	C112	472	½ HP	Not connected

### 4.5 Domestic Hot Water System

Domestic hot water is provided by an electric tank heater with 15 kW heating capacity from three elements and 405 litres storage capacity. The domestic hot water recirculation pump (P-5) is controlled by the DDC.

### 4.6 Controls System

The HVAC system is controlled by a Delta Controls DDC, using ORCAView 3.40. Remote access to the system is available.

Boilers, boiler pumps, and P-2 are on BACnet protocol. Other systems use the older “V2” protocol.

Zone heating (coils and radiators) are not shown in the DDC graphics.

### 4.7 Other Equipment

The school has a 50 kW<sub>p</sub> roof-mounted solar PV system, connected to the electrical system through two string inverters.

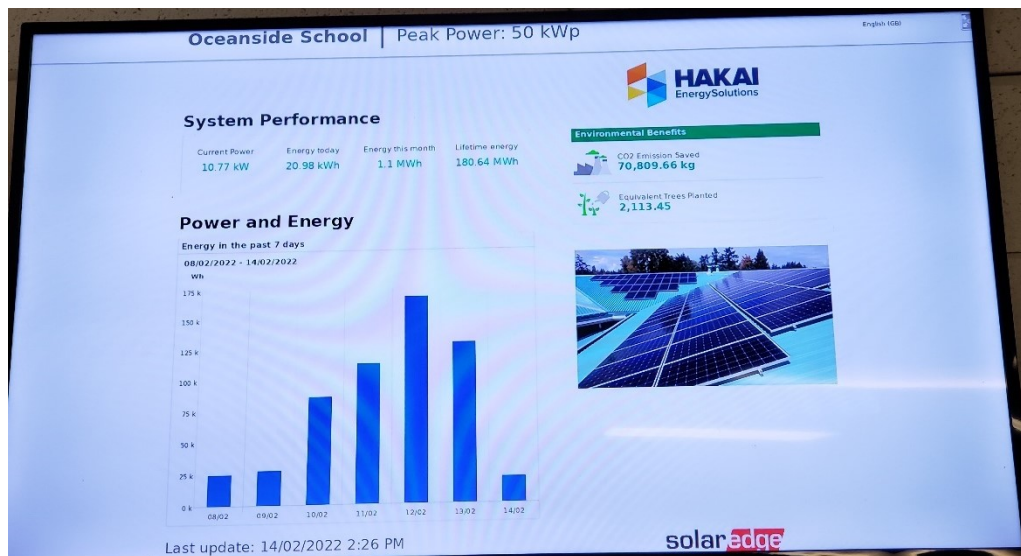

Figure 4: Solar PV Dashboard

## 5.0 Measures Selected for Implementation (Under C.Op. Program)

This section provides an overview of each measure, recommendations for implementation, and an update after implementation.

### 5.1 New Measures

#### 5.1.1 Measure 1: AC-1 operates during unoccupied hours

##### Description of Finding

Outside occupied hours, AC-1 operates to maintain unoccupied setback temperatures based on the temperature of coldest room it serves (the DDC analog value AC1\_LOW\_RT). This variable is always 0 due to an apparent error in the programming (Figure 6 and Figure 7), so AC-1 operates continuously.

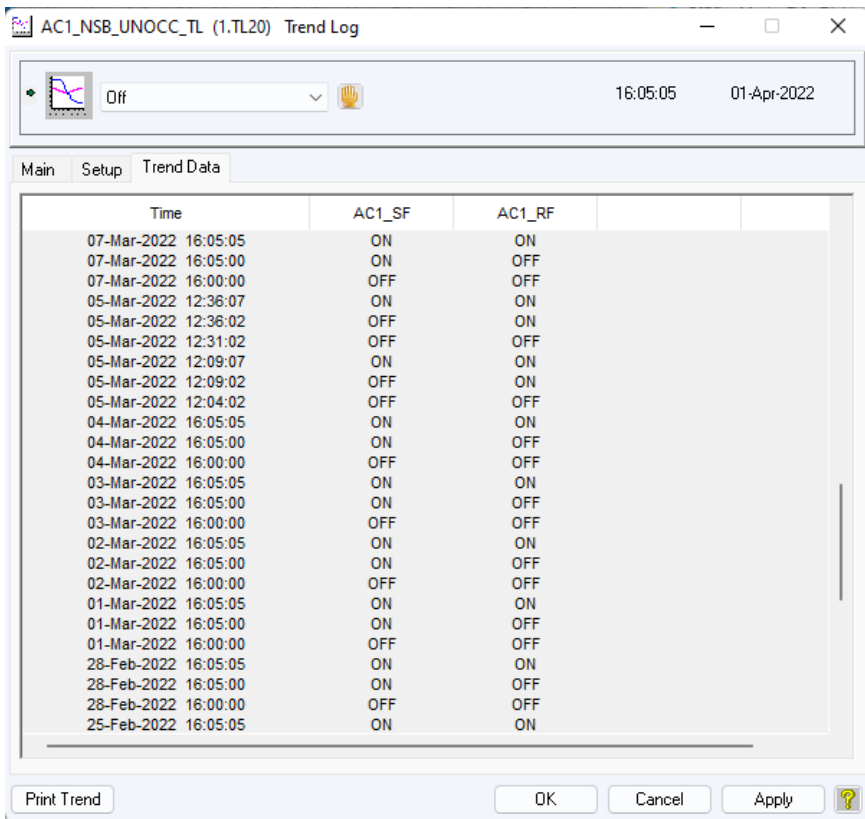

**Figure 5: Both AC-1 supply and return fans operate continuously, except for brief shutdowns between occupancy modes**

```

40 ●
41 ● [***** NIGHT SETBACK *****]
42 ● IFONCE AC1_WS OFF THEN AC1_NSB = AC1_NSB_SP ENDIF
43 ● IFONCE TIME = 23:00 THEN AC1_NSB = AC1_UNOCC_SP ENDIF
44 ● IF AC1_WS = OFF THEN
45 ●   AC1_NMD = SWITCH(AC1_NMD , AC1_LOW_RT , AC1_NSB , AC1_NSB + 1 )
46 ● ELSE
47 ●   AC1_NMD = OFF
48 ● ENDIF
49 ●

```

AC1\_LOW\_RT = 0.0

Figure 6: AC1\_LOW\_RT is always zero and does not reflect actual room temperatures

Figure 7: AC1\_LOW\_RT appears to be calculated from non-temperature values or variables with no defined value.

The outdoor air damper remains at least 30% open whenever the supply fan operates. It only closes if return air temperature drops below 16°C. This seldom occurs because the AC-1's zones are always maintained at occupied temperature setpoints, including during scheduled unoccupied hours.

Figure 8: Typical reheat controller



## Measure Description

Correctly calculate AC1\_LOW\_RT from room temperature readings in the spaces served by AC-1. This will enable the air handler to only run when required to maintain space setpoints.

## Measure Implementation Update

[Provide confirmation details **AFTER** the measure is implemented and verified]

### 5.1.2 Measure 2: Gymnasium HV-2 operates continuously

#### Description of Finding

During unoccupied periods, gymnasium air handler HV-2 operates if the temperature of the coldest space served by HV-2 (HV2\_LO\_RT) is lower than HV-2's night setback temperature setpoint (HV2\_NSB, overridden to 19°C). The value of HV2\_LO\_RT remains constant at 18.1°C, which is not the gymnasium temperature. This causes HV-2 to operate continuously.

```

49 ● HV2_DMP_RAMP = 0
50 ● ENDIF
51 ●
52 ● [***** HV2_NIGHT MODE *****]
53 ●
54 ● IF HV2_WS = OFF AND HV2_WS_EA = OFF THEN
55 ●   HV2_NMD = SWITCH(HV2_NMD , HV2_LO_RT , HV2_NSB , (HV2_NSB + 1) )
56 ● ELSE
57 ●   HV2_NMD = OFF
58 ● ENDIF
    
```

HV2\_LO\_RT = 18.1

Figure 9: HV2\_LO\_RT value on 17 April 2022, 2:29PM

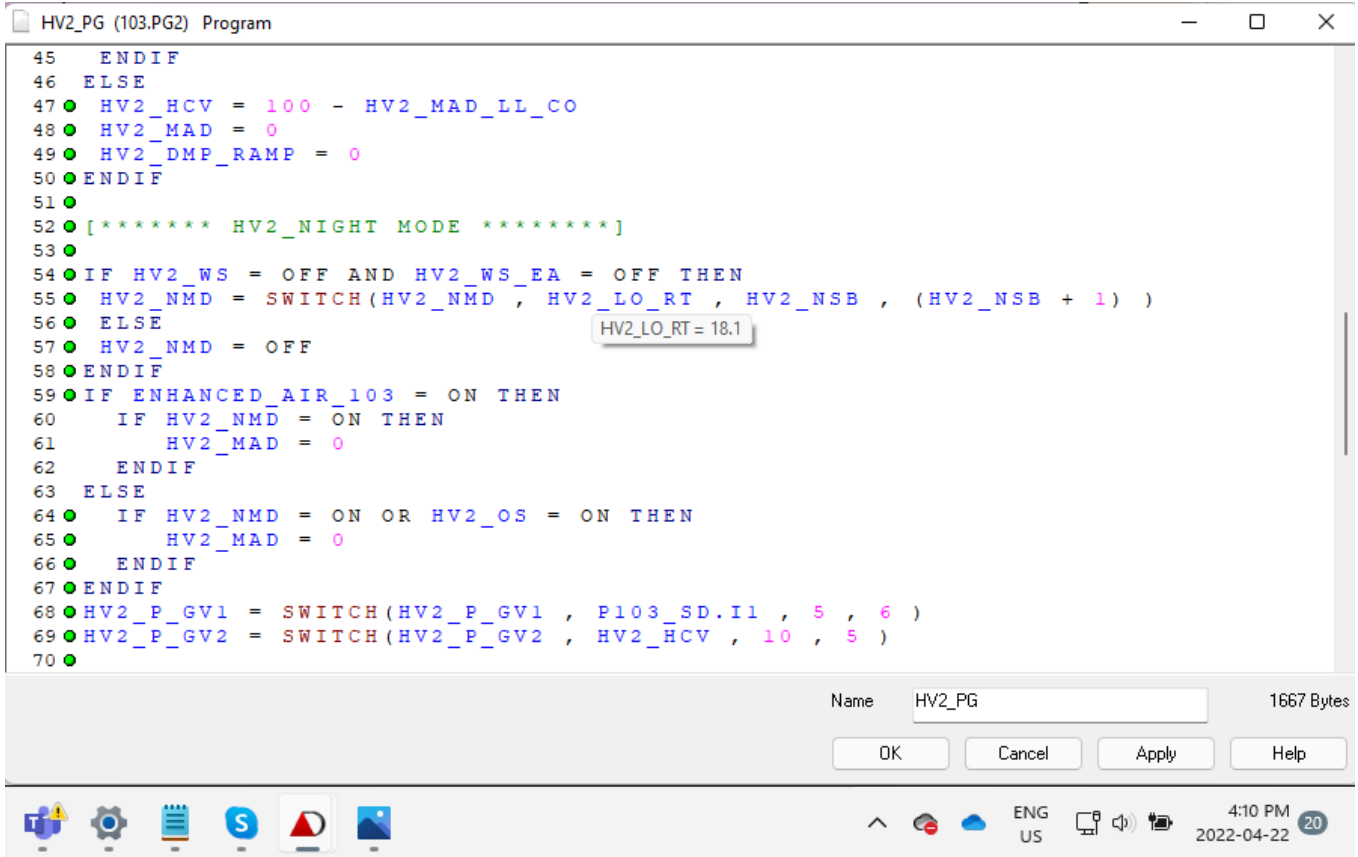

Figure 10: value of HV2\_LO\_RT on April 22, 4:10pm

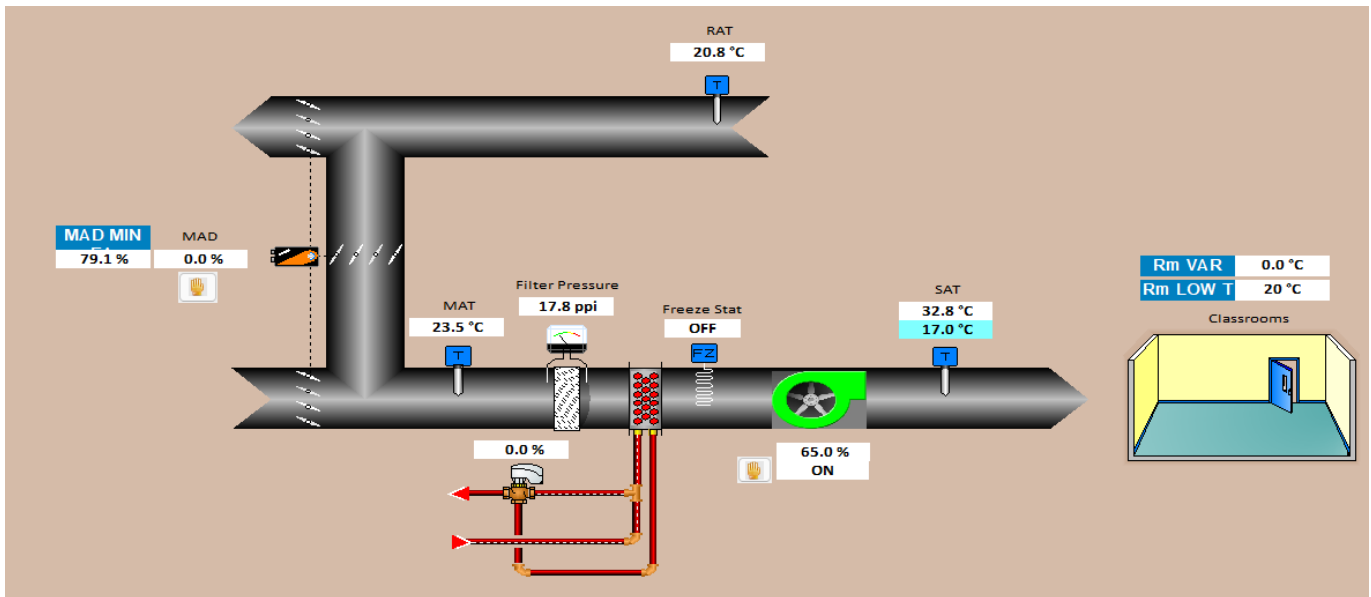

Figure 11: HV-2



### Measure Description

Calculate the value of HV2\_LO\_RT correctly using the existing gymnasium zone temperature sensors. This will allow HV-2 to shut down during unoccupied hours when its unoccupied setback temperature is satisfied.

### Measure Implementation Update

[Provide confirmation details **AFTER** the measure is implemented and verified]

### 5.1.3 Measure 3: HV-3 operates continuously

#### Description of Finding

HV-3 operates continuously, including during its scheduled unoccupied hours. Outside of scheduled occupied hours, HV-3 is programmed to start if the temperature of the coldest zone it serves is below its night setback setpoint (19°C). However, this variable (HV3\_LOW\_RT) is always 0, apparently because it is calculated using sensors that have been removed.

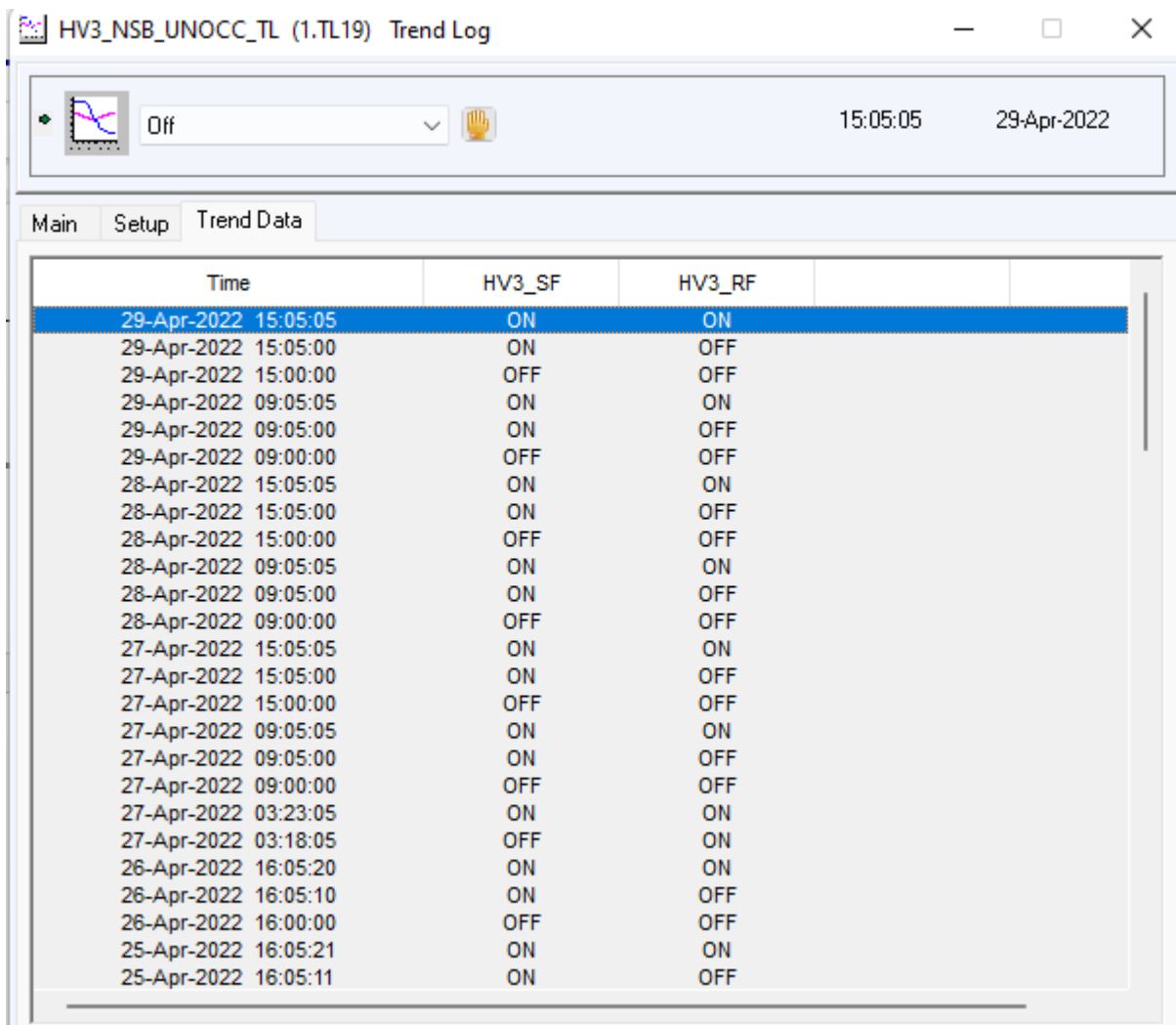

Figure 12: HV-3 fans run except for brief stops when occupancy mode changes

```

63 ● IF HV3_WS = OFF OR HV3_WS_EA = OFF THEN
64 ● HV3_NMD = SWITCH(HV3_NMD , HV3_LOW_RT , HV3_NSB , (HV3_NSB + 1)
65 ● ELSE
66 ● HV3_NMD = OFF
67 ● FNDTF

89 ● [***** HV ROOM TEMPERATURE SELECT*****]
90 ● HV3_LOW_RT = LSEL (RAD_MP5_IC.S1 , RAD_MP6_IC.S1 )
91 ● HV3_LOW_RT = LSEL (HV3_LOW_RT , RAD_MP15_IC.S1 )
92 ● HV3_LOW_RT = LSEL (HV3_LOW_RT , RAD_MP17_IC.S1 )
93 ● HV3_LOW_RT = LSEL (HV3_LOW_RT , RAD_MP18_IC.S1 )
94 ●
    
```

HV3\_LOW\_RT = 0.0

Figure 13: HV3\_LOW\_RT value does not reflect actual room temperatures

### Measure Description

Calculate HV3\_LOW\_RT using HV-3’s functioning zone temperature sensors only. This will enable HV-3 to shut down during unoccupied periods when night setbacks are satisfied.

### Measure Implementation Update

[Provide confirmation details **AFTER** the measure is implemented and verified]

## 5.1.4 Measure 4: Air handler schedules

### Description of Finding

HV-1, HV-2, and HV-3’s weekly scheduled occupied hours begin at 4am on Monday to Wednesday. On other days, they begin at 7am.

The 7am Thursday and Friday start time indicates that a 7am start time is sufficient to warm up the building in time for regular occupied hours (offices are occupied at 8am, classes at 8:45am) and that the earlier Monday to Wednesday start time is not required.

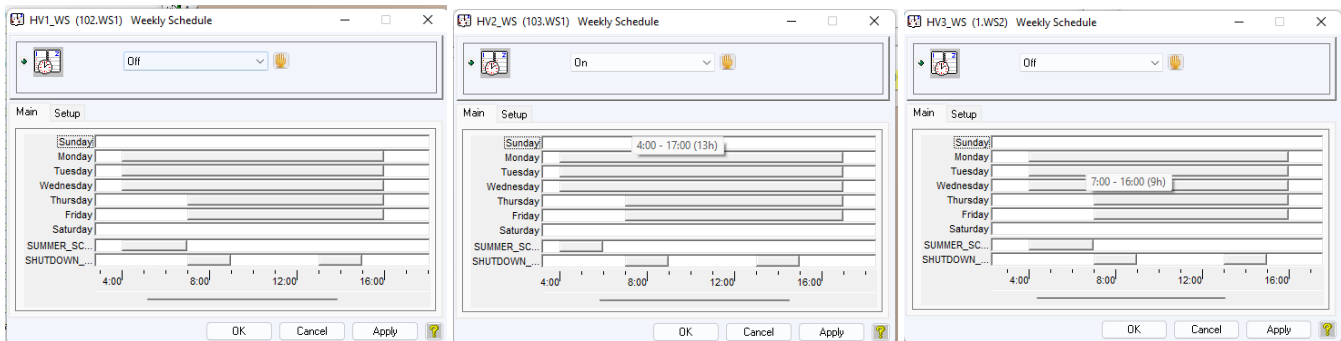

Figure 14: HV-1, HV-2, HV-3 schedules

### Measure Description

Modify schedules for HV-1, HV-2, and HV-3 so the start time is 7am on all weekdays. Since the building may take longer to warm up after the weekend, the system may need to start slightly earlier on Monday morning for the room temperature to reach setpoint in time for occupancy.

For further savings, the DDC can be programmed to adjust start times based on outdoor air temperature and room temperatures, since it takes more time to warm up the building on a cold morning than on a warmer day when the building has retained most of the heat from the previous day. This is commonly known as “optimal start”. The start time should be calculated separately for each air handler, since they have different occupancy times (e.g. start AC-1 in time to bring office/admin spaces to temperature by 8am).

### Measure Implementation Update

[Provide confirmation details **AFTER** the measure is implemented and verified]

#### 5.1.5 Measure 5: HV-3 excess ventilation

##### Description of Finding

Figure 1 shows HV-3 with its mixed air damper above minimum and its heating coil open at the same time. In this operating condition, HV-3 is drawing more cold outdoor air into the school than necessary for indoor air quality, only to immediately heat it as required for occupant comfort.

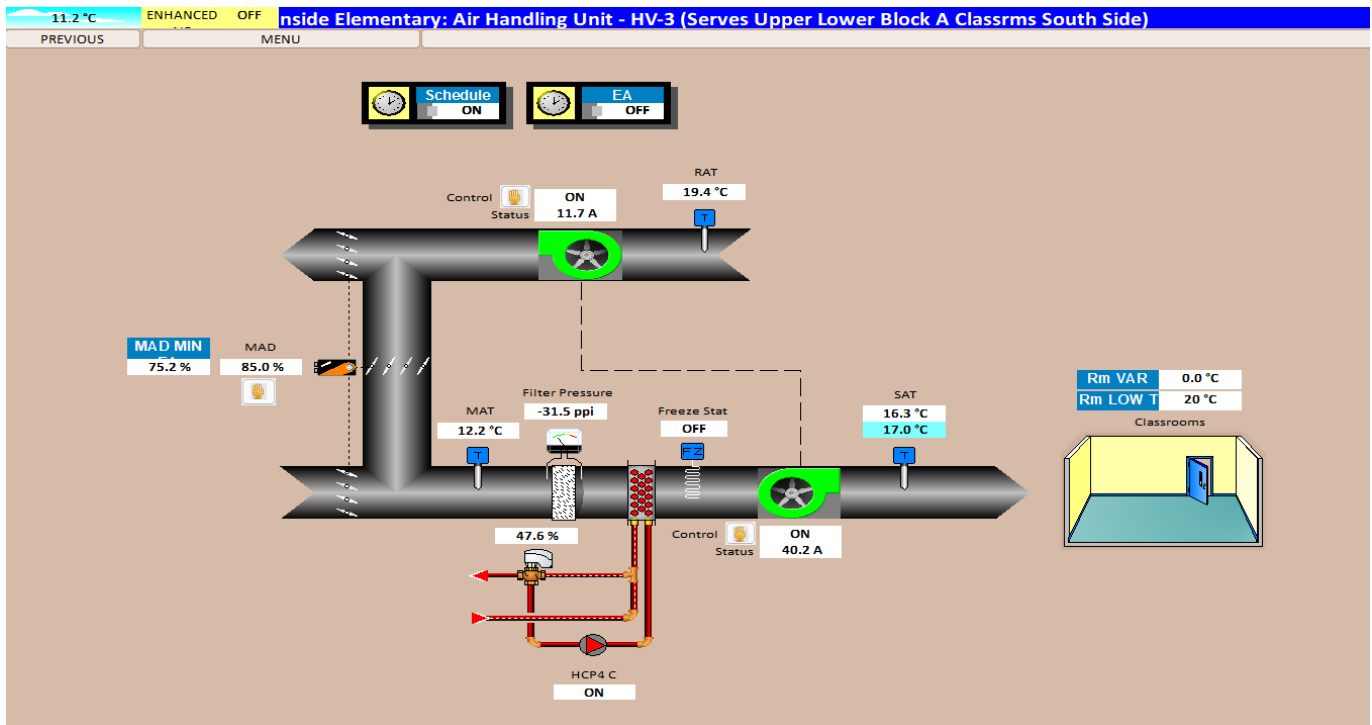

Figure 15: HV-3 has simultaneous high outdoor air and heating

Both the mixed air damper and the heating coil control valve modulate to maintain supply air temperature at its setpoint. This leads to situations where both the dampers and heating coil valve open more than required, resulting in simultaneous heating and cooling.

```

HV3_PG (1.PG3) Program
25
26 [***** SUPPLY TEMPERATURE CALCULATION *****]
27
28 HV3_SAT_SP = 16 - (3 * HV3_RM_VAR)
29 HV3_SAT_SP = LIMIT(HV3_SAT_SP, 17, 22)
30 HV3_HCV_SP = HV3_SAT_SP - 1
31 IF ENHANCED_AIR_SYS = ON THEN [ENHANCED AIR]
32   HV3_MAT_SP = HV3_SAT_SP - 2
33 ELSE
34   HV3_MAT_SP = HV3_SAT_SP
35 ENDIF
36 [***** HV3 DAY CONTROL *****]
37
    
```

Figure 16: HCV targets SAT = SAT\_SP – 1. MAD targets SAT = SAT\_SP

Figure 17: Overlapping bands on the HCV and MAD controllers enables heating and increased outdoor air at the same time

**Figure 18: Typical reheat control to maintain 19°C RT**

**Measure Description**

Implement a single split range control loop that controls both damper and heating valve.

**Measure Implementation Update**

[Provide confirmation details **AFTER** the measure is implemented and verified]

**5.1.6 Measure 6: Boiler supply setpoint higher when unoccupied**

**Description of Finding**

During occupied hours, the boiler setpoint has been manually set to 50°C. Outside the boiler schedule (6:30am to 6pm Monday to Friday), the boiler setpoint changes to 60°C. This results in lower boiler efficiency, and higher heat losses from pipes.

```

24 Else //if unoccupied
25   If OAT_ENABLE = On Then //if unoccupied and below 2 degC
26     BLR_RESET = BLR_SWT_SP_MIN
27     SEC_LOOP_P2_ENAB = 20000.AV3 = 60 °C

```

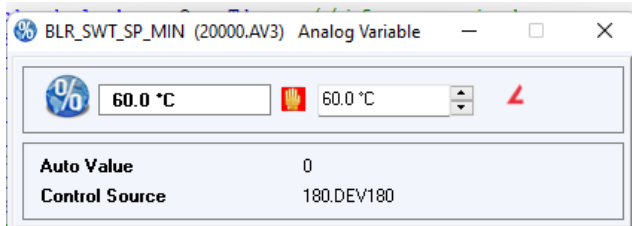

**Figure 19: Boiler temperature is set to 60°C when unoccupied**

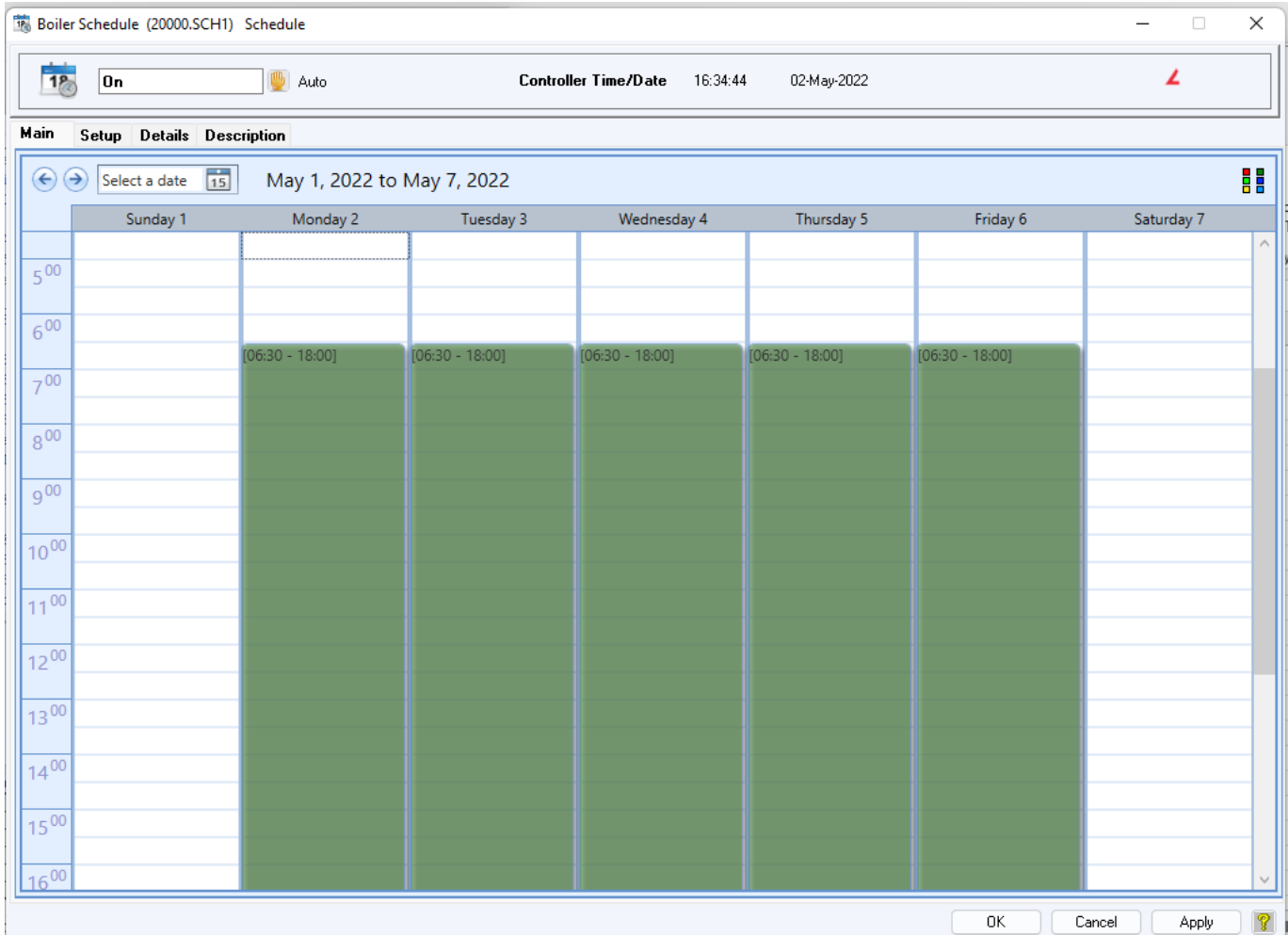

**Figure 20: Boiler schedule**

**Measure Description**

Reduce boiler supply minimum temperature variable (BLR\_SWT\_SP\_MIN; the programmed unoccupied boiler supply water temperature setpoint per Figure 19) to 50°C.

**Measure Implementation Update**

[Provide confirmation details **AFTER** the measure is implemented and verified]

**5.1.7 Measure 7: Night setbacks for reheats and fan coils**

**Description of Finding**

The controllers for the hydronic duct reheat coils and fan coil units do not have night setbacks configured and they will attempt to maintain rooms to their typical daytime setpoints, even during unoccupied hours.

In addition, the reheat coils are programmed to provide heat regardless of whether their air handling units are operating.

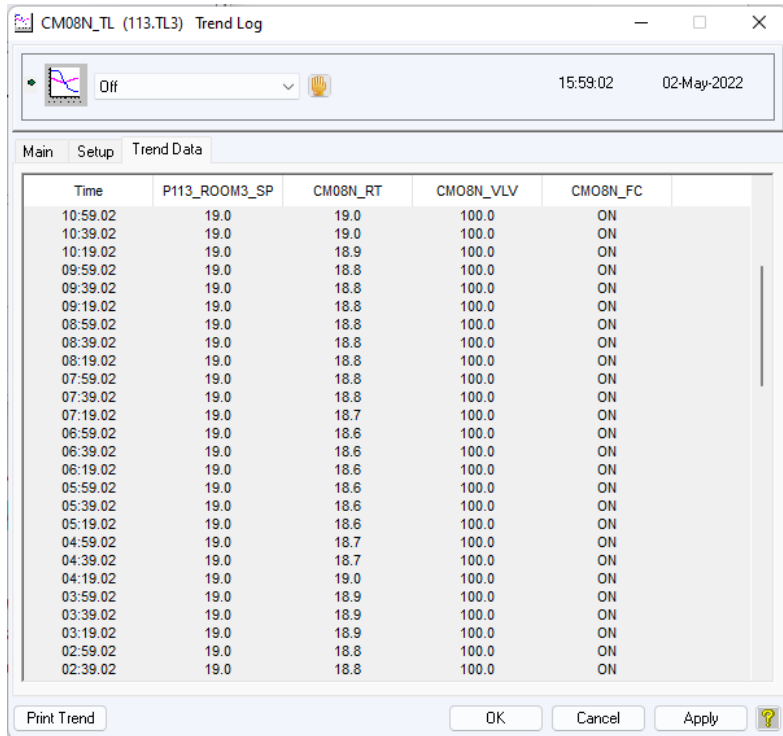

Figure 21: Fan coil CM08N. Room temperature remains at constant 19°C setpoint continuously

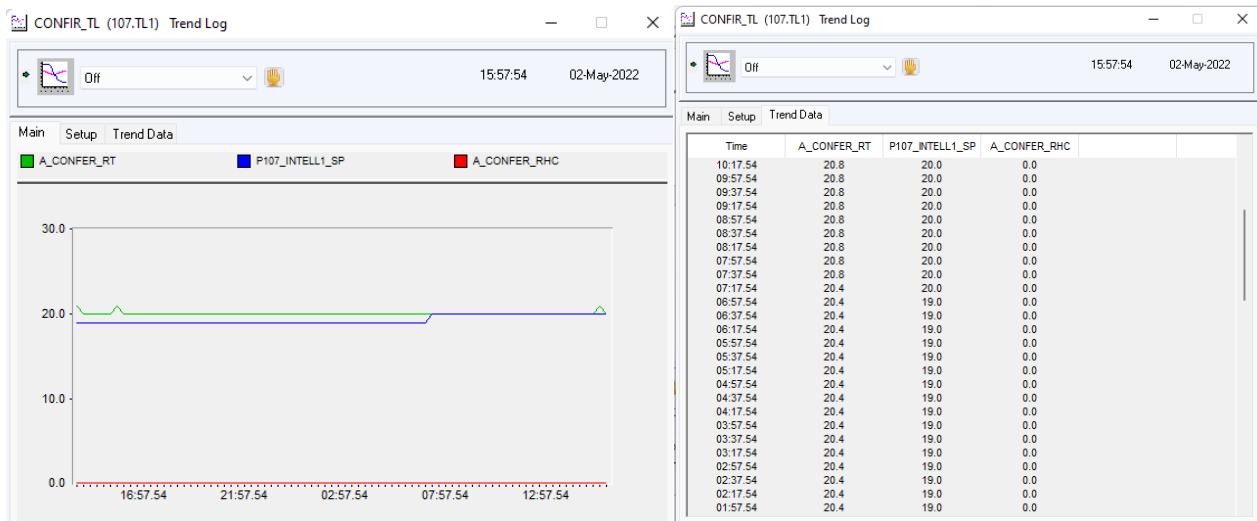

Figure 22: The typical zone night setback temperature setpoint is 19°C, which provides limited energy savings

### Measure Description

Reducing the room temperatures while unoccupied will reduce heat loss through the envelope (walls, windows, etc.) and save energy. We recommend reducing room temperature setpoints for all equipment to 15°C during unoccupied periods.

Reprogram reheat coil control valves to close whenever the corresponding air handling units are disabled.

Show reheat coils in the DDC graphics for improved visibility and troubleshooting.

**Measure Implementation Update**

[Provide confirmation details **AFTER** the measure is implemented and verified]

**5.1.8 Measure 8: HV-3 occupancy schedule out-of-date**

**Description of Finding**

The HV-3 occupancy schedule includes a secondary “shutdown” calendar which provides two 2-hour periods of operation, likely intended to maintain air quality during extended unoccupied period. The schedule appears to be from a previous year and causes the air handler to run on Saturdays and Sundays, over 6 weeks in March and April (a total of 12 days).

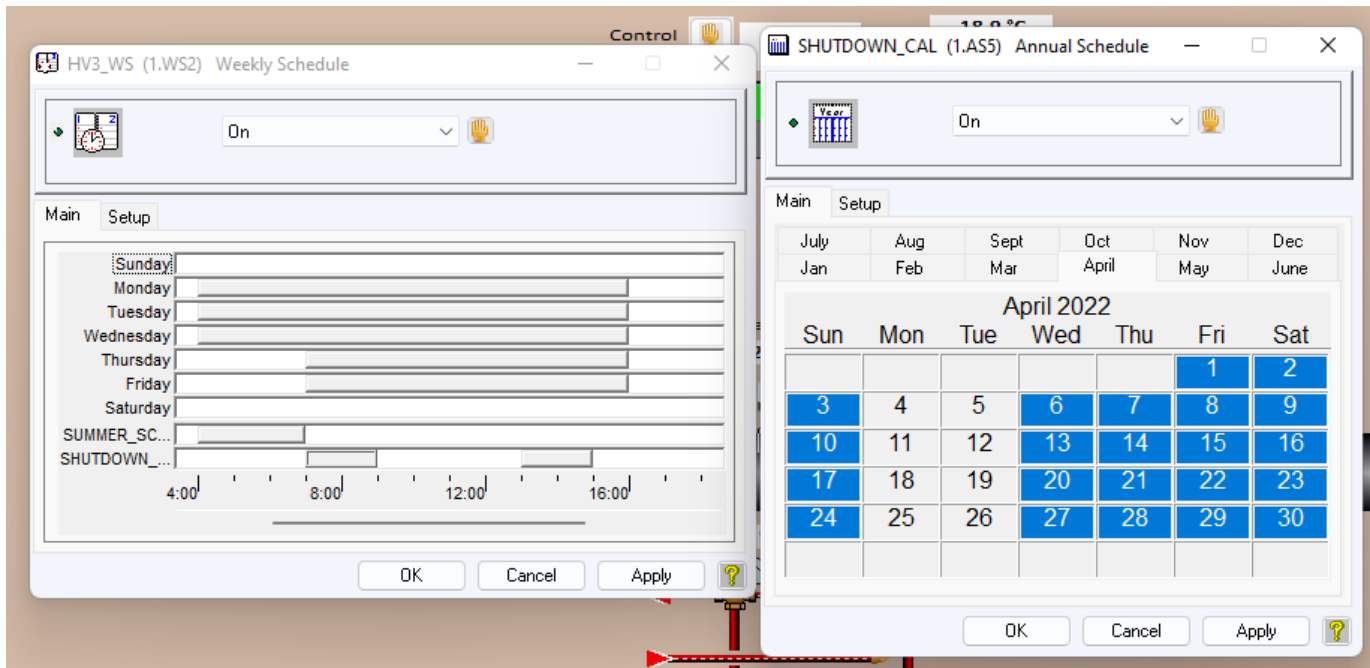

**Measure Description**

Review shutdown schedules and remove unnecessary entries.

**Measure Implementation Update**

[Provide confirmation details **AFTER** the measure is implemented and verified]



### 5.1.9 Measure 9: HV-2 fan or coil issue

#### Description of Finding

Figure 23 shows HV-2 operating with its heating coil control valve closed but a supply air temperature of 31.8°C. This suggests the heating coil is passing, or there is an issue with the supply air temperature sensor.

This issue appeared in late April and was not present during earlier inspections of the DDC.

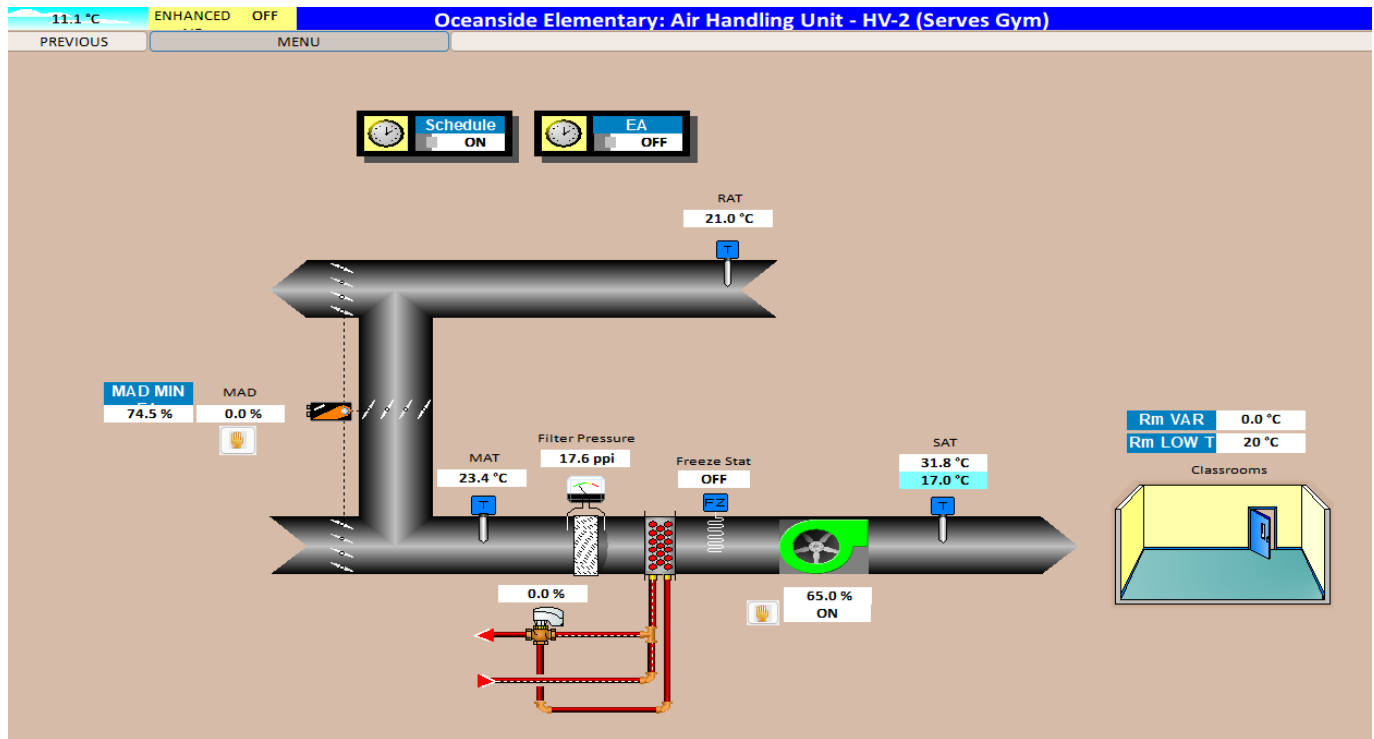

Figure 23: Significant increase in air temperature over the heating coil (and fan)

#### Measure Description

Validate the supply air temperature sensor with a manual temperature reading in the field.

Operate HV-2 with the supply fan enabled and the heating coil control valve commanded fully closed (0%). Manually measure the air temperature at the coil inlet and outlet. A temperature rise indicates a passing valve. Furthermore, the heating coil inlet and outlet pipes should be cold after the control valve is closed for several minutes.

Measure costs assume the control valve requires repair or replacement.

#### Measure Implementation Update

[Provide confirmation details **AFTER** the measure is implemented and verified]

### 5.1.10 Measure 10: Fan sensor issues

#### Description of Finding

Several fans have inconsistent feedback values. There are no energy savings associated with this measure, but possible comfort or air quality issues.

#### EFC-02

The feedback from exhaust fan EFC-02 (Science Rooms, A220, served by HV-3) indicates it never runs, even when commanded on.

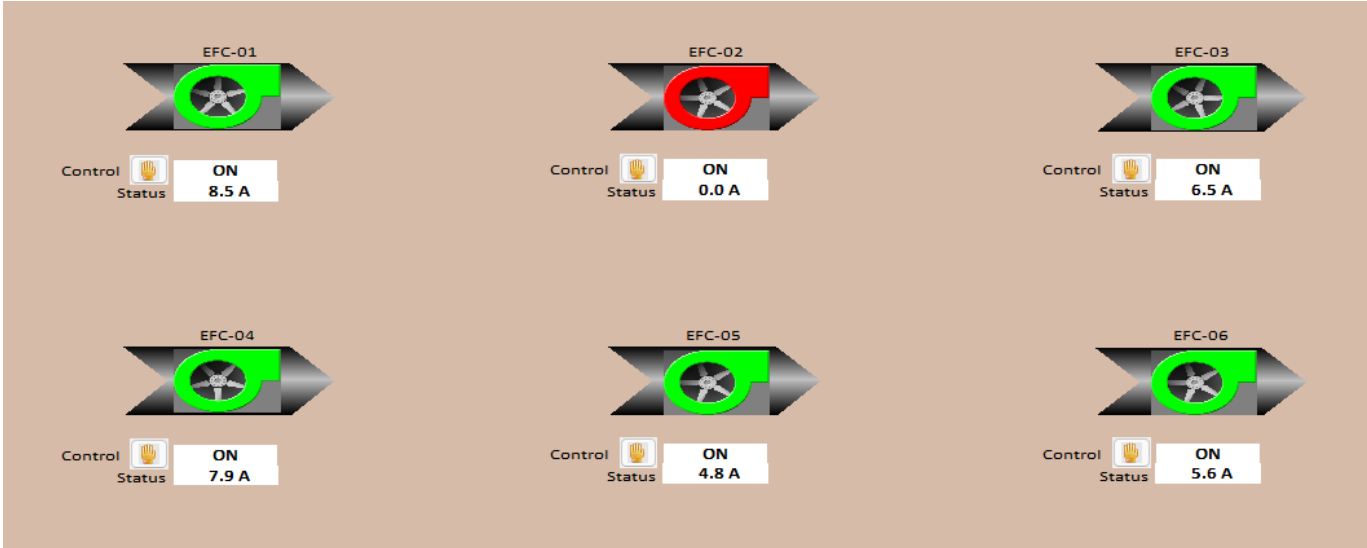

Figure 24: Exhaust fans in the DDC

#### AC-1 Supply Fan

The AC-1 supply fan feedback sensor shows a very different current (5 A) than what is specified for the fan motor (30 A), as seen in Figure 3.

This is likely a sensor issue. The air handler will function normally while the sensor reading remains higher than 3 A, but it may become an issue if the sensor degrades further.

#### HV-2 Supply Fan

The HV-2 supply fan feedback variable (HV2\_SFVD\_S) is 'Off' even when the fan is commanded to run. In this error state, the outdoor air dampers are always closed, and heating is minimized. This is leading to temperature and air quality issues in the gym.

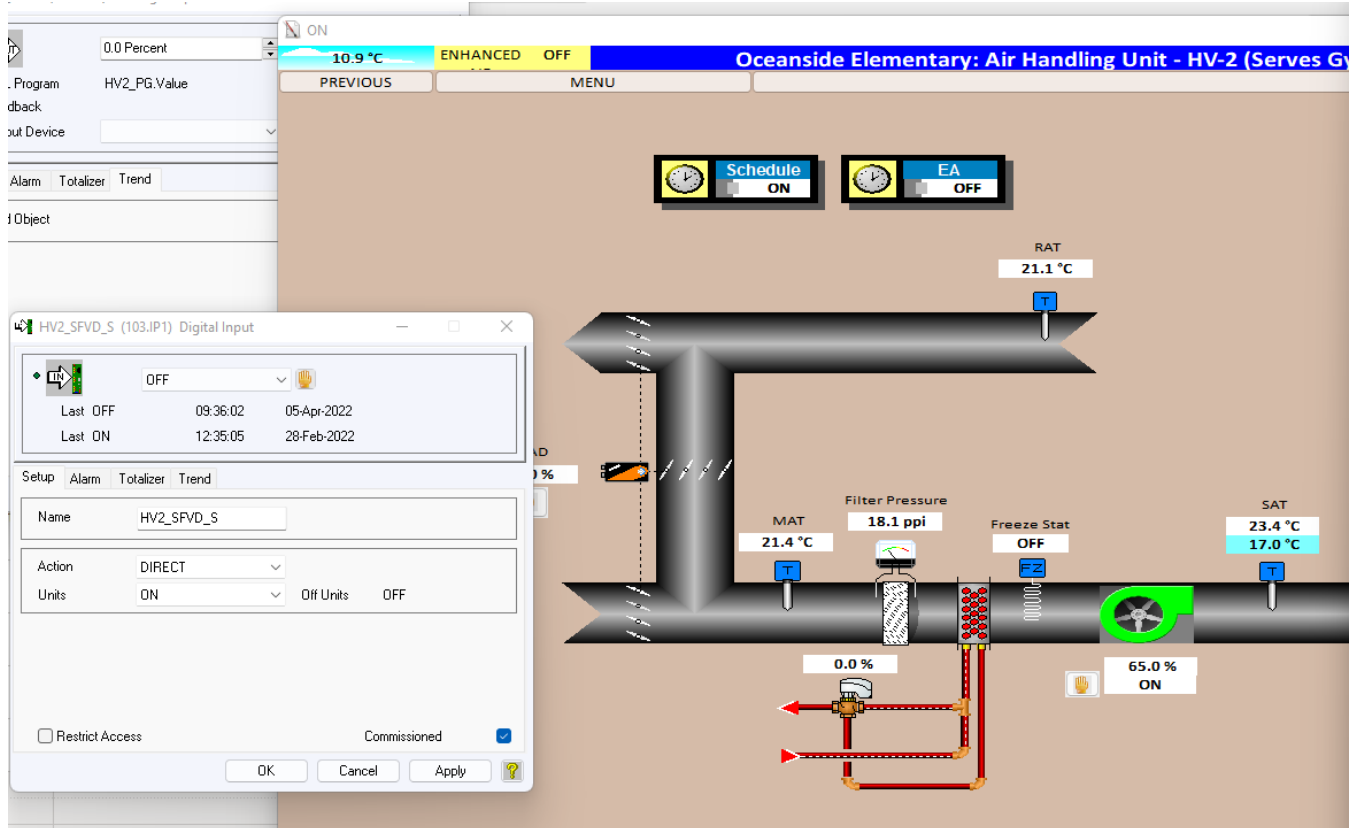

Figure 25: The value of HV2\_SFVD\_S is off even when the supply fan is commanded on.

```

32 ● IF HV2_SFVD_S = ON THEN
33   HV2_HCV = HV2_HCV_CO
34   HV2_DMP_RAMP = HV2_DMP_RAMP + 0.1
35   HV2_DMP_RAMP = LIMIT(HV2_DMP_RAMP , 0 , 100 )
36   IF ENHANCED_AIR_103 = ON THEN
37     HV2_MAD = LIMIT(HV2_MAD_CO , MAD_MIN_POS103 , 100 )
38     HV2_MAD = LSEL(HV2_MAD , HV2_MAD_LL_CO )
39   ELSE
40     HV2_MAD = LIMIT(HV2_MAD_CO , HV2_MAD_MIN , 100 )
41     HV2_MAD = LSEL(HV2_MAD , HV2_MAD_LL_CO , HV2_DMP_RAMP )
42   ENDIF
43   IF HV2_RAT < 16 THEN
44     HV2_DMP_RAMP = 0
45   ENDIF
46 ELSE
47 ● HV2_HCV = 100 - HV2_MAD_LL_CO
48 ● HV2_MAD = 0
49 ● HV2_DMP_RAMP = 0
50 ● ENDIF

```

Figure 26: HV-2 MAD is set to 0 if there is no fan feedback.

## Measure Description

### EFC-02

Confirm whether EFC-02 runs when commanded on. If not, identify and correct issue with the fan or connections. If it runs, the fan feedback sensor or connections should be corrected.

### AC-1 Supply Fan

Verify the AC-1 supply fan feedback sensor correctly reports that status of the fan by manually checking AC-1 supply fan's status in the field. If the sensor is faulty, it should be repaired or replaced. If the reading is correct, there may be an issue with the fan motor.

### HV-2 Supply Fan

Verify the HV-2 supply fan feedback sensor by manually checking if the fan is running in the field and comparing it with the current feedback. If the sensor is faulty, it should be repaired or replaced. If the reading is correct, there may be an issue with the fan.

Update DDC graphics to reflect measured feedback, for example by showing the fan in red or green depending on the measured state.

## Measure Implementation Update

[Provide confirmation details **AFTER** the measure is implemented and verified]

### 5.1.11 Measure 11: DHW circulation pump manually on

#### Description of Finding

The DHW recirculation pump (P-5) has been overridden to operate continuously.

Running the pump outside of scheduled hours causes a (small) energy penalty and distribution losses.

The purpose of the pump is to ensure hot water immediately at taps and showers throughout the building, so it should run whenever custodial staff or other occupants are in the building.

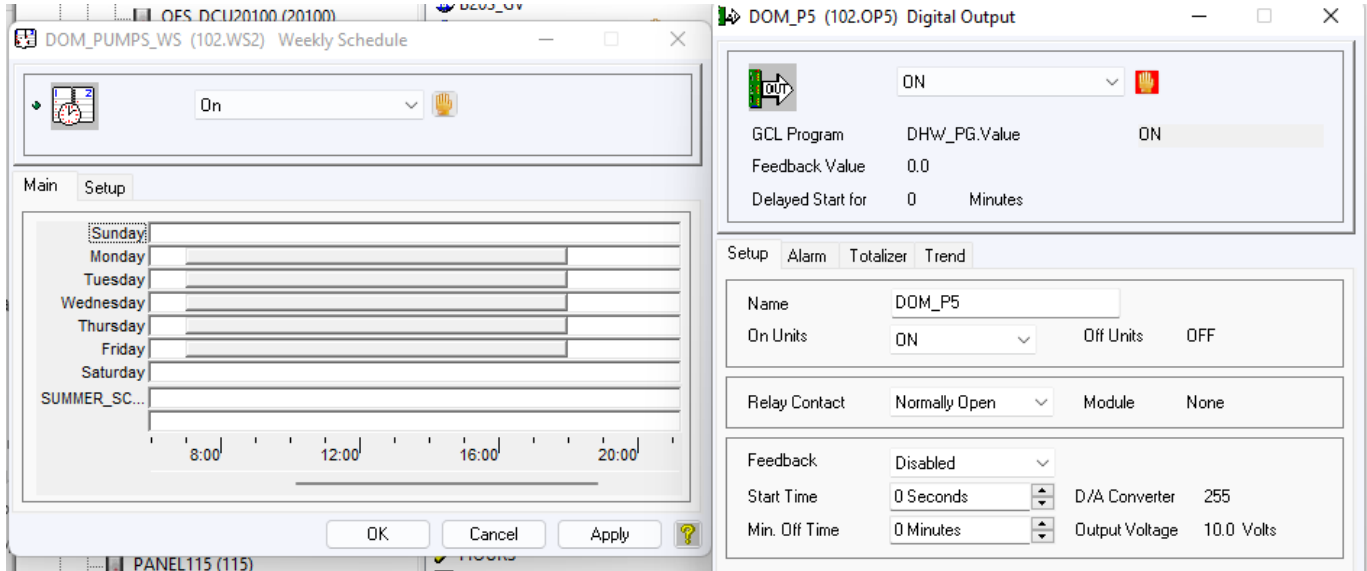

**Figure 27: The P-5 schedule has been manually overridden**

**Measure Description**

Adjust the pump schedule to match occupancy, including custodial staff working outside regular occupancy hours. Remove manual override.

**Measure Implementation Update**

[Provide confirmation details **AFTER** the measure is implemented and verified]

**6.0 Measures to be considered for Future Implementation**

This section provides an overview of each measure (that was identified but **was not selected** as part of this C. Op. project, but maybe considered for future implementation), recommendations for implementation, and the most suitable method for providing evidence of implementation. See Appendix A - Investigation Phase Summary Table for more details.

**6.1 Measure 12: Add reversible heat pump to boiler loop**

**Measure Description**

The boiler loop supply temperature is currently set manually to 50°C without any reported comfort issues. Commercially available air and ground source heat pumps can efficiently heat water to this temperature. This makes Oceanside Elementary an excellent candidate for low carbon electrification by supplementing the existing boilers plant with air or ground source heat pumps.

If the chiller connected to AC-1 is original to the building (1993), it would be nearing its end-of-service-life. If so, we propose replacing it with a two-pipe reversible air source heat pump able to heat or chill water depending on season. If a unit of similar cooling capacity to the existing chiller is selected (25 Tons, based on the AC-1 cooling coil specification), it will not require additional electrical capacity.

The current supply and return pipes from the chiller to AC-1 pass close by the boilers plant in the basement mechanical room. This makes it inexpensive to connect a heat pump installed in place of AC-

1's chiller with the heating water loop. During summer, the heat pump would provide cooling as it does now, serving AC-1<sup>1</sup>. In winter, the heat pump would provide 1<sup>st</sup>-stage heating to the heating water loop, supplemented by the existing boilers as required.

A feasibility study is recommended as the next step to assessing the viability of this project. The boiler plant's heating water supply temperature should be trended through winter to confirm the fraction of the year a heat pump could supplement Oceanside's heating. Mechanical and structural assessments are required to refine the cost and viability of the project.

Estimated measure costs include all work required to replace the existing chiller with a heat pump. If the existing AC-1 chiller is nearing end-of-life, the base case cost (replacing the chiller like-for-like) may be similar.



**Figure 28: Basement mechanical room. Chiller water pipe marked in blue. The boilers are on the right.**

---

<sup>1</sup> If the school district is considering cooling in other parts of the school, for example as a climate resilience measure to manage extreme heat events, the chilled water piping could be extended supply other zones. This would require a larger heat pump, installation of additional cooling equipment, and higher project costs.

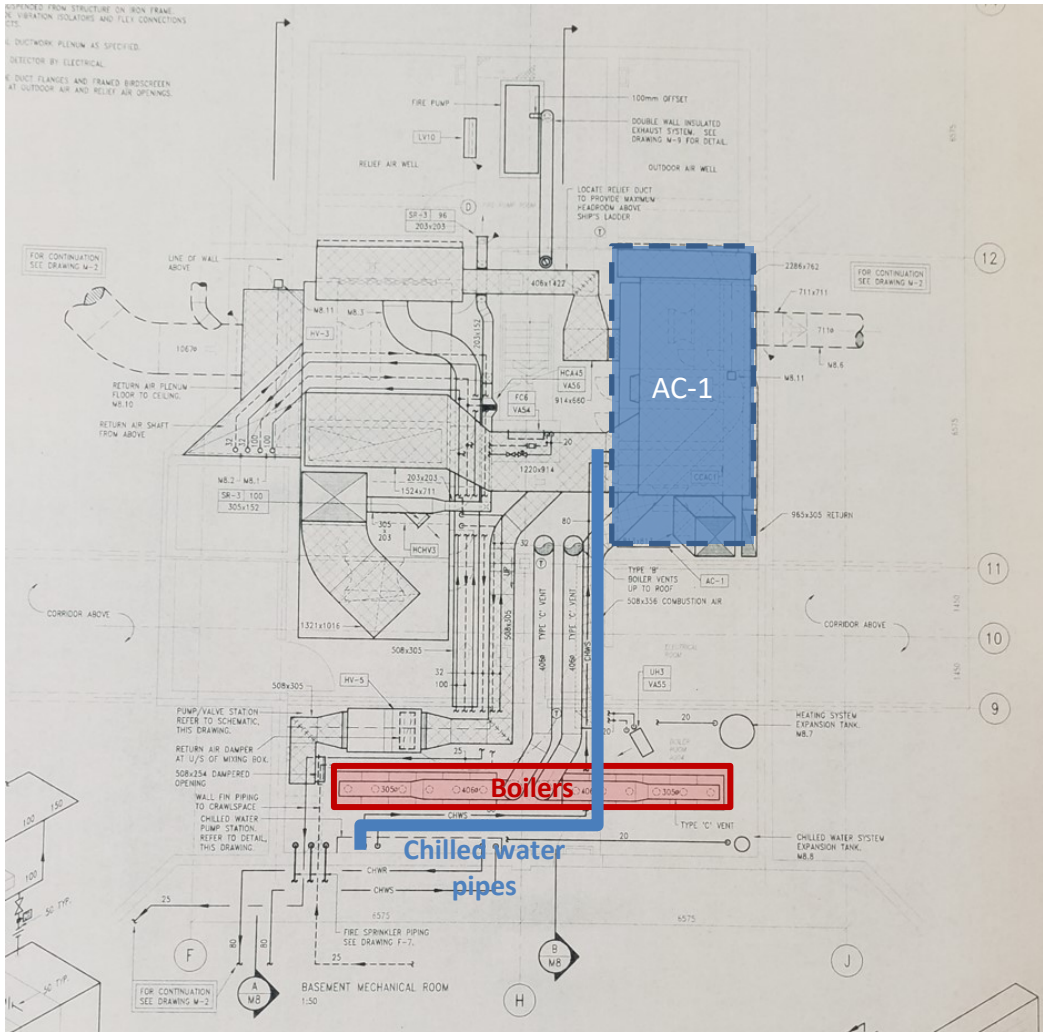

Figure 29: Basement mechanical room. Supply and return pipes from the existing chiller pass close to the boiler plant and heating loop.

## 7.0 Next Steps – Implementation Phase and Completion Phase

### 7.1 Implementation Phase

To continue in the program, the owner is responsible for implementing the selected bundle of measures that pay back in two years or less. Using the *Recommissioning Report* for implementation allows flexibility in how the selected measures are implemented. Options include: utilize in-house building staff, hire the C.Op Provider to implement or provide technical assistance, contract with outside service contractors, or any combination of the above.

### 7.2 Completion Phase

C.Op Service provider will follow up after implementation of the selected measures and **update** this *Recommissioning report and Recommissioning Workbook*.



The updated report for the implemented measures includes but not limited to: date of completion of each measure, new or improved sequences of operation, the energy savings impact of the measures, the requirements for ongoing maintenance and monitoring of the measures, and contact information for the service provider, in house staff, and contractors responsible for the implementation. When feasible, verification data should include trends or functional test results, though other methods, such as copies of invoices, site visit reports, and before/after photos, may be acceptable.

The C.Op Service Provider will conduct an in-house (teleconference) session for the Applicant and the appropriate building operations personnel covering the new documentation, measures that were implemented, and requirements for ongoing maintenance and monitoring. Document the attendance of the building operations staff.

The *updated Recommissioning Workbook* and *updated Recommissioning Report* will be submitted to the owner and the program for review. See Appendix B: Completion Phase Summary Table for more details on implemented measures.



## Appendix A: Investigation Phase Summary Table

Investigation Phase Summary				Investigation Phase							
ECM #	Measure Title	Measure History	Include cost	Energy Savings			Cost Savings	Financial		Est. GHG Reduction	Enter "x" if DESELECT for implementation
				Demand (kW)	Electrical (kWh/yr)	Fuel (GJ)	Total (\$/yr)	Estimated Measure Cost (\$)	Simple Payback (yrs)	tonnes CO2e/yr	
ECM-1	AC-1 operates continuously	New	1	-	56,057	195	\$ 7,892	\$ 600	0.1	10.3	
ECM-2	HV-2 operates continuously	New	1	-	24,135	-	\$ 2,381	\$ 600	0.3	0.3	
ECM-3	HV-3 operates continuously	New	1	-	68,334	-	\$ 6,741	\$ 200	0.0	0.7	
ECM-4	Air handler schedules	New	1	-	1,419	61	\$ 877	\$ 400	0.5	3.0	
ECM-5	HV-3 excess ventilation	New	1	-	-	168	\$ 2,043	\$ 1,100	0.5	8.4	
ECM-6	Boiler supply setpoint higher when unoccu	New	1	-	-	28	\$ 344	\$ 200	0.6	1.4	
ECM-7	Night setbacks for reheats and fan coils	New	1	-	-	120	\$ 1,457	\$ 4,100	2.8	6.0	
ECM-8	HV-3 occupancy schedule out-of-date	New	1	-	-	2	\$ 28	\$ 200	7.0	0.1	
ECM-9	AHU-2 coil issue	New	1	-	-	228	\$ 2,761	\$ 4,800	1.7	11.4	
ECM-10	Fan sensor issues	New	1	-	-	-	\$ -	\$ 900	#DIV/0!	-	
ECM-11	DHW circulation pump manually on	New	1	-	236	-	\$ 23	\$ 200	8.6	0.0	
ECM-12	Reversible heat pump connected to hydron	New	1	-	64,316	755	\$ 2,811	\$ 236,929	84.3	37.0	x
TOTAL (Previous, still working):				-	-	-	\$ -	n/a	n/a	-	
TOTAL (All potential measures for Implementation):				-	85,865	1,558	\$ 27,359	\$ 250,229	9.1	78.6	
TOTAL (Selected measures only):				-	150,182	803	\$ 24,548	\$ 13,300	0.5	41.6	

## Appendix B: Completion Phase Summary Table

[Paste image of Completion Summary Table from the RCx Workbook AFTER Implementation]

## Appendix C: Sample Training Outline

### [Completion Report AFTER Implementation]

The Commissioning Provider (C.Op Provider) may customize the outline for the training and developing the training materials. Before preparing the training outline and materials, the C.Op Provider should assess the related level of knowledge of the building operators, to set up the training accordingly. For reference, the Program provides the following sample outline for the training:

- Background on the energy use of this particular building
  - Present Energy Utilization Index
  - Describe Operating Schedules and Owner's operating requirements
- RCx investigation process used in this building
  - Describe the methods used to identify problems and deficiencies
  - Review the RCx Workbook
- Implementation process in this building
  - Describe the measures that were implemented and by whom
  - Walk around the building to look at any physical changes or step through the new control sequences at the operator workstation
  - Provide as many details about implementation as necessary to describe what was done
  - Describe improved performance that these measures will create (show trends if available)
- O&M requirements
  - Describe the O&M requirements needed to keep these improvements working
  - Describe how the staff can be aware of energy efficiency opportunities and begin looking for additional savings potential

The C.Op Provider should follow the outline to prepare materials, as necessary, to hand out at the training session.



## Appendix D: Training Completion Form

Project ID
------------

### Facility Information

Company Name	Building Name(s)	
Facility Address	City	Province

### Training Details

Location	Date
Commissioning Provider/Trainer	

### Materials Attached

<input type="checkbox"/> Agenda
<input type="checkbox"/> Materials used for training
<input type="checkbox"/> List of individuals who attended

#### COMMISSIONING PROVIDER SIGNATURE

By signing this Training Completion Form, I verify that this training took place with the listed attendees.	
Commissioning Provider (print name):	
Signature:	Date:

**FACSIMILE/SCANNED SIGNATURES:** Facsimile transmission of any signed original document, and the retransmission of any signed facsimile transmission, shall be the same as delivery of the original signed document. Scanned original documents transmitted to BC Hydro as an attachment via electronic mail shall be the same as delivery of the original signed document. At the request of BC Hydro, C.Op Provider shall confirm documents with a facsimile transmitted signature or a scanned signature by providing an original document.



Targeted Documentation

O & M Manual

O & M Manual updated <input type="checkbox"/>	Describe updates below and attach copies of new or amended portions
O & M Manual not updated <input type="checkbox"/>	Province reasons below
Building has no O & M Manual <input type="checkbox"/>	

Building Plans (“as-builts”)

Building Plans updated <input type="checkbox"/>	Describe below
Wiring diagrams updated <input type="checkbox"/>	Describe below
No plans or diagrams updated <input type="checkbox"/>	Describe below

EMS Programming

New sequences of operation on file <input type="checkbox"/>	Specify location of file and attach copy
Printed screenshots on file <input type="checkbox"/>	Specify location of file and attach copy

Equipment Manuals



Manuals for new equipment are on file <input type="checkbox"/>	Describe below (attach copy if applicable)





Continuous Optimization for Commercial Buildings Program

# Recommissioning Report

---

Version	Updated on	Phase
1	July 12, 2022	Investigation

Prepared for:

School District 69

Qualicum Beach Elementary School

699 Claymore Rd

Qualicum Beach, BC

Project: BCH-07836

Prism Project: 2021300

---

Prepared by:

Prism Engineering Ltd.

#320 - 3605 Gilmore Way

Burnaby, BC







# TABLE OF CONTENTS

<b>1.0</b>	<b>INTRODUCTION .....</b>	<b>3</b>
<b>2.0</b>	<b>PROJECT OVERVIEW .....</b>	<b>4</b>
<b>3.0</b>	<b>SAVINGS SUMMARY .....</b>	<b>5</b>
<b>4.0</b>	<b>BRIEF DESCRIPTION OF EXISTING SYSTEM .....</b>	<b>6</b>
4.1	FACILITY DESCRIPTION .....	6
4.2	HEATING SYSTEM .....	6
4.3	VENTILATION SYSTEM .....	8
4.4	DOMESTIC HOT WATER SYSTEM .....	9
4.5	CONTROLS SYSTEM (INCLUDES LIGHTING CONTROLS IF APPLICABLE) .....	9
4.6	OTHERS.....	9
<b>5.0</b>	<b>MEASURES SELECTED FOR IMPLEMENTATION (UNDER C.OP. PROGRAM) .....</b>	<b>10</b>
5.1	MEASURE 1: AHU HEATING COIL VALVE PASSING .....	10
5.2	MEASURE 2: AHU-1 RUNS CONTINUOUSLY .....	12
5.3	MEASURE 3: AHU-4 RANDOM OPERATION.....	14
5.4	MEASURE 4: REHEAT VALVES BLOCKED OR PASSING .....	16
5.5	MEASURE 5: DAILY HVAC OPERATION SCHEDULE .....	19
5.6	MEASURE 6: SUMMER HVAC OPERATION SCHEDULE.....	19
5.7	MEASURE 7: DHW PUMPS RUN CONTINUOUSLY.....	20
5.8	MEASURE 8: EXHAUST FAN FEEDBACK.....	21
5.9	MEASURE 9: AHU-4 DAMPER ISSUE.....	22
<b>6.0</b>	<b>MEASURES TO BE CONSIDERED FOR FUTURE IMPLEMENTATION .....</b>	<b>24</b>
6.1	MEASURE 10: REPLACE AC-1 CONDENSING UNIT WITH AIR-TO-WATER HEAT PUMP .....	24
6.2	MEASURE 11: AIR SOURCE HEAT PUMP CONNECTED TO BOILER PLANT.....	25
<b>7.0</b>	<b>NEXT STEPS – IMPLEMENTATION PHASE AND COMPLETION PHASE.....</b>	<b>28</b>
7.1	IMPLEMENTATION PHASE .....	28
7.2	COMPLETION PHASE.....	28
<b>APPENDIX A:</b>	<b> INVESTIGATION PHASE SUMMARY TABLE .....</b>	<b>29</b>
<b>APPENDIX B:</b>	<b> COMPLETION PHASE SUMMARY TABLE .....</b>	<b>30</b>
<b>APPENDIX C:</b>	<b> SAMPLE TRAINING OUTLINE.....</b>	<b>31</b>
<b>APPENDIX D:</b>	<b> TRAINING COMPLETION FORM .....</b>	<b>32</b>

## 1.0 Introduction

Prism Engineering is pleased to present the results of the Investigation Phase that was conducted as part of BC Hydro's Continuous Optimization for Commercial Buildings Program for Qualicum Beach Elementary. The objective of an Investigation is to identify deficiencies and improvements in the operation of a facility's mechanical equipment, lighting, and related controls, and determine opportunities for corrective action that reduce energy consumption and preserve the indoor environmental quality.

This document is a complete record of the work performed at this facility, including the in-depth investigation of the building systems and the implementation of selected measures to optimize building performance.

The Recommissioning Investigation Report provides an overview of the recommendations for the implementation of measures. This information is not considered a specification or detailed sequence of operations. The intent is to provide an overview of the recommendation that can be built upon during the implementation phase as part of any detailed design that may be required. Certain measures may require further investigation and specification for the correct implementation by the owner or the DDC contractor.

Nine recommended retrofits were identified as a part of this investigation. The proposed measures will be reviewed in a meeting with SD69 and Prism Engineering representatives to determine which measures will be implemented.

- Measure 1: AHU heating coil valve passing
- Measure 2: AHU-1 runs continuously
- Measure 3: AHU-4 random operation
- Measure 4: Reheat valves blocked or passing
- Measure 5: Daily HVAC operation schedule
- Measure 6: Summer HVAC operation schedule
- Measure 7: DHW pumps run continuously
- Measure 8: Exhaust fan feedback
- Measure 9: AHU-4 damper issue

These measures are presented in the Investigation Summary Table (see Appendix A).

While the investigation focuses on low-cost improvements with short paybacks, some capital improvement opportunities may also be identified. Major retrofit measures are beyond the scope of this program, but other BC Hydro and FortisBC programs provide a variety of incentives to complete the retrofits. Retrofits were identified as a part of this investigation that could potentially qualify for other BC Hydro and FortisBC programs, these measures are described in Section 6.

Retrofits include:

- Measure 10: Replace AC-1 condensing unit with air-to-water heat pump
- Measure 11: Air source heat pump connected to boiler plant



## 2.0 Project Overview

<b>Project Information</b>		<i>Complete cells this background colour</i>	
RCx Project File #	<b>BCH-07836</b>		
Date of Workbook Update	12-Jul-2022		
Organization	School District 69		
Building Name	Qualicum Beach Elementary School		
Building Type	Large School		
Location (City)	Qualicum Beach, BC		
Owner Contact	Phil Munro		
Investigation Phase start date	01-Feb-2022		
Participated in previous BCH RCx program?	No		
Previous RCx File #			
Previous RCx completion date			
<b>Building Information</b>			
Facility Area (ft <sup>2</sup> )	53,120		
Annual elec consumption (kWh)	260,356	4.9	kWh/ft <sup>2</sup>
Annual elec costs (\$)	\$ 25,661	\$ 0.10	Avg. \$/kWh
Fuel type	Natural Gas		
Annual fuel consumption (GJ)	1,742	9.1	ekWh/ft <sup>2</sup>
Annual fuel cost (\$)	\$ 21,118	\$ 12.1	Avg. \$/GJ
Total GHG emissions (tCO <sub>2</sub> e/yr)	90		
Total Energy Cost	\$ 46,779	\$ 0.88	\$/ft <sup>2</sup>
Energy Use Intensity (ekWh/ft <sup>2</sup> )	14.0		
Year for energy data above	2021		



### 3.0 Savings Summary

Savings Summary	Previous, still working	New + Previous, rectify + Previous, documented					
		Identified		Selected		Implemented	
	# of measures	11		9		9	
		0					
	Re-claim Savings	Total Savings	% Savings	Total Savings	% Savings	Total Savings	% Savings
Electrical savings (kWh/yr)	-	16,198	-6.2%	119,998	46.1%	119,998	46.1%
Fuel savings (GJ/yr)	-	2,191	125.8%	748	42.9%	748	42.9%
Cost savings (\$)	\$ -	\$ 24,969	53.4%	\$ 20,889	44.7%	\$ 20,889	44.7%
GHG reduction (tCO2e/yr)	-	109.1	121.7%	38.6	43.0%	38.6	43.0%
# of Abandoned measures	0						



## 4.0 Brief Description of Existing System

This section contains a brief description of the existing HVAC and Controls system. The information is intended to provide a general overview only.

### 4.1 Facility Description

The Qualicum Beach Elementary School was built 2002 and has a floor area of 53,120 sqft. The building contains classrooms, admin offices, gym, library, arts, music, drama, and technical teaching spaces.

**Table 1: Schedules**

	Area	Days	Start	End
Occupancy	Classes	All Days	8:50am	2:36pm
	Office hours	All Days	8am	3:30pm
Building operation	HVAC (main schedule)	Monday-Wednesday	4am	4pm
		Thursday-Friday	7am	4pm
	Gym (AHU2)	Monday-Friday	8am	4:30pm
	Boilers	Monday-Friday	6:30am	7pm

While the HVAC operating calendars allow for different operation on holidays, no holidays have been defined for air handlers. Boilers are shut down in July and August.

### 4.2 Heating System

Heating is provided by four 399 MBH (input) IBC condensing boilers. Each has a dedicated circulating pump. The primary boiler loop is connected to the secondary loop via a low loss header.

The supply water temperature is reset between 40 and 82°C depending on outdoor air temperature and building load (determined by the difference between building loop supply and return water). Boilers are disabled above 17°C outdoor air temperatures.

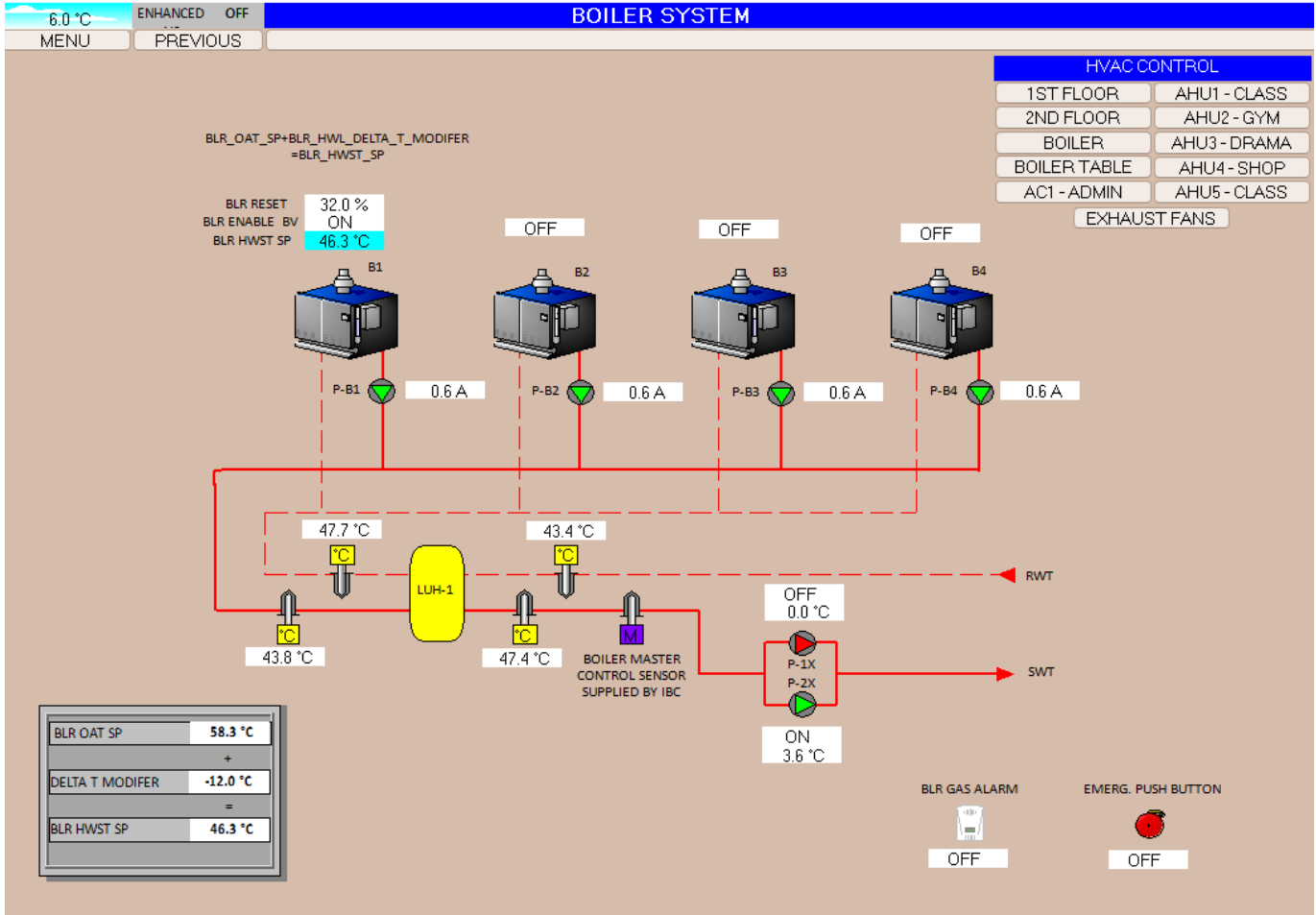

**Figure 1: Boilers in the DDC**

Heating water is distributed to heating coils in air handlers, duct reheat coils, fan coil units, radiant panels, and a unit heater.

**Table 2: Building Pumps**

Tag	Serves	Size	VSD	Flow (GPM)	Head (Ft)
BP1 to BP4	Boiler pumps	157W @ 1.4A (0.6A on DDC)	No		
P-7	Heating loop	1.5 HP each	No	93 GPM	32 Ft
P-8	Lead-lag				
P-9	DHW boiler/tank circulation	1/6 HP 3.6 FLA	No		
P-10	DHW recirculation	58 W	No		



### 4.3 Ventilation System

The building has five heating-only air handlers, and one unit with heating and cooling. HV-4 and HV-5 are in the mechanical room at the East end of the building. The other units are on the roof, at the East end of the building.

**Table 3: Air handlers**

Tag	Service	Airflow (cfm)	Supply Fan Power (hp)	Return Fan Power (hp)	Coils	Outdoor air
AC-1	Admin/Office, Tech, Library	8,110	7.5	3	Heating 20 ton 2-stage DX	Mixed Min 20%
HV-1 / AHU-1*	General Offices and Classrooms	14,000**	10**	5**	Heating	Mixed Min 30%
HV-2 / AHU-2*	Gymnasium	21,600	15 VSD	7.5** VSD	Heating	Mixed Min 20%
HV-3 / AHU-3*	Music / Multi-purpose	7,930	5	3	Heating	Mixed Min 20%
HV-4 / AHU-4*	Construction	4,000**	3**	2	Heating	Mixed Min 30%
HV-5 / AHU-5*	North Classrooms	11,345	7.5	3	Heating	Mixed Min 15%

\* Both IDs are used interchangeable in the DDC and other documentation.

\*\* Estimated based on area served and sizing of similar units

**Table 4: Exhaust fans**

Tag	Service
EF-1	Gym change rooms
EF-2	Storage (104,112)
EF-3	Kitchen range hood
EF-4	Storage (116)
EF-5	Copy 125
EF-6	Washroom 143
EF-7	Elevator 122
EF-8	Kitchen range 126
EF-9	Main washrooms
EF-10	Science 209



EF-11	207, 211, 213
EF-12	Science 215
EF-13	Fume Hood 209
EF-14	Fume hood 215
EF-5	Home Ec. 163
EF-16	Room 159
EF-17	Hood 159
EF-18	221, 165, 167, 171
EF-19	Rm 169
EF-20	Telecom 217
EF-21	Staff Room 123
EF=22	Telecom 145A

#### **4.4 Domestic Hot Water System**

Domestic hot water is provided by a 399 MBH input AO Smith atmospheric water heater with an external storage tank. Pump P-9 circulates water between boiler and tank. Pump P-10 recirculates domestic hot water through the building.

#### **4.5 Controls System (includes Lighting Controls if Applicable)**

The HVAC system is controlled by a Delta Controls DDC, using ORCAView 3.40. Remote access to the system is available.

#### **4.6 Others**

The school has a 60 kW roof-mounted solar photovoltaic system, installed in 2021. It has a Tesla backup battery.



## 5.0 Measures Selected for Implementation (Under C.Op. Program)

This section provides an overview of each measure, recommendations for implementation, and update after implementation.

For each measure, costs, savings and payback calculations can be referenced in the *Investigation Summary Table* (see Appendix A).

### 5.1 Measure 1: AHU heating coil valve passing

#### 5.1.1 Description of Finding

##### AHU-1

AHU-1 supply air temperature is consistently 4-5°C higher than mixed air temperature when its heating valve is commanded closed. This was the case when Figure 8 was captured.

As a result, additional outdoor air must be brought in as cooling to keep the supply air at setpoint. During unoccupied operation, when outdoor air dampers are kept shut, it can also lead to overheating.

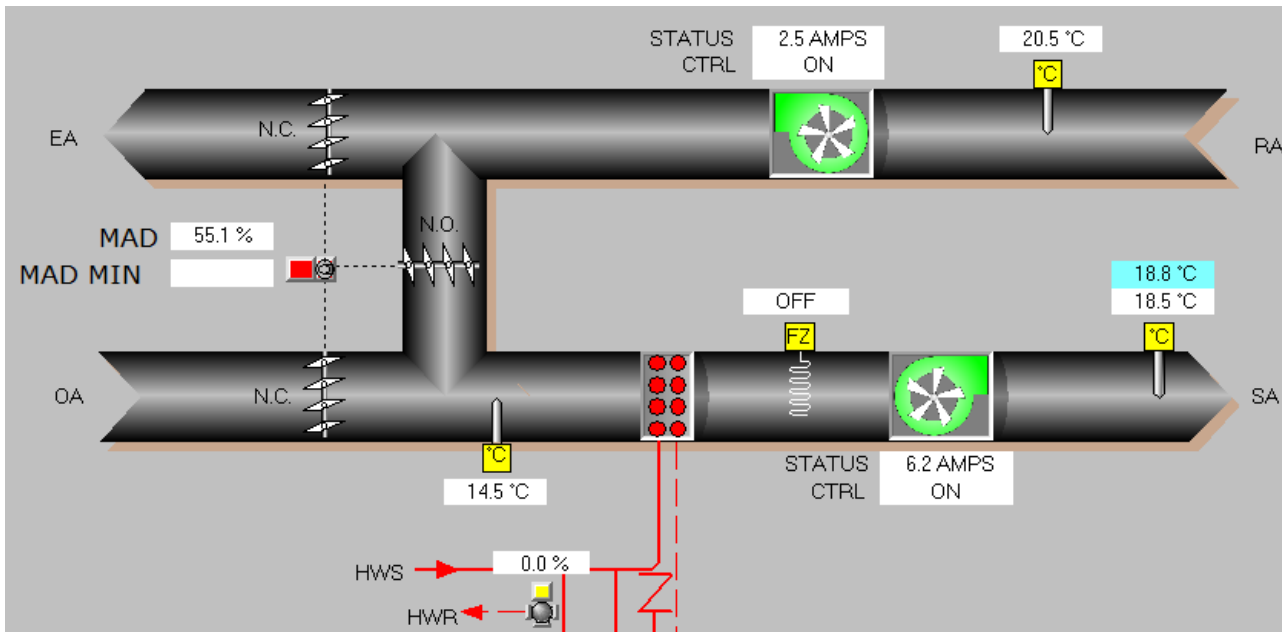

Figure 2: AHU-1, SAT is 5°C higher than MAT, with HCV at 0%

##### AHU-5

Figure 3 shows AHU-5 heating supply air by 2.5°C despite its control valve being fully closed. This suggests the valve is passing. Figure 4 shows the supply air temperature exceeds 30°C overnight (when AHU-5 is off), which also indicates passing.

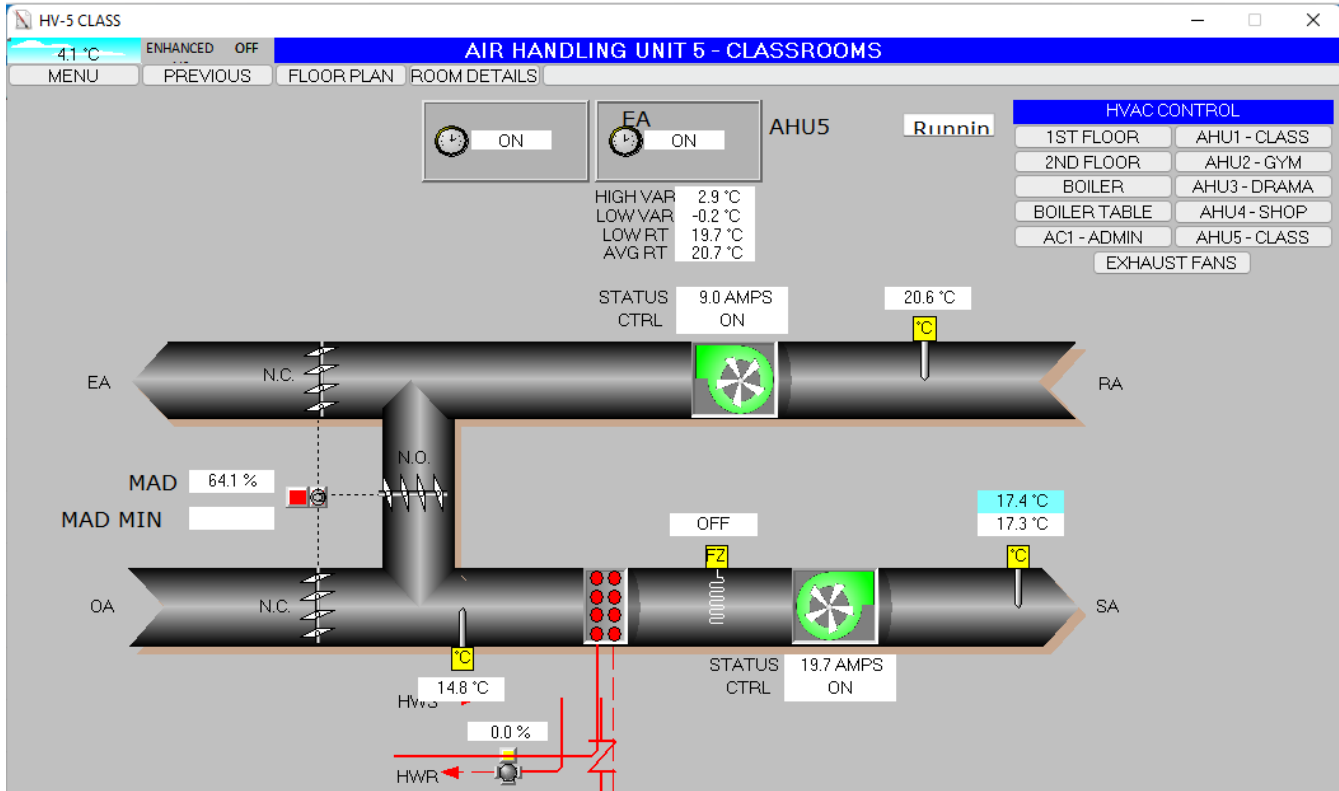

Figure 3: AHU-5 heating despite the control valve closed.

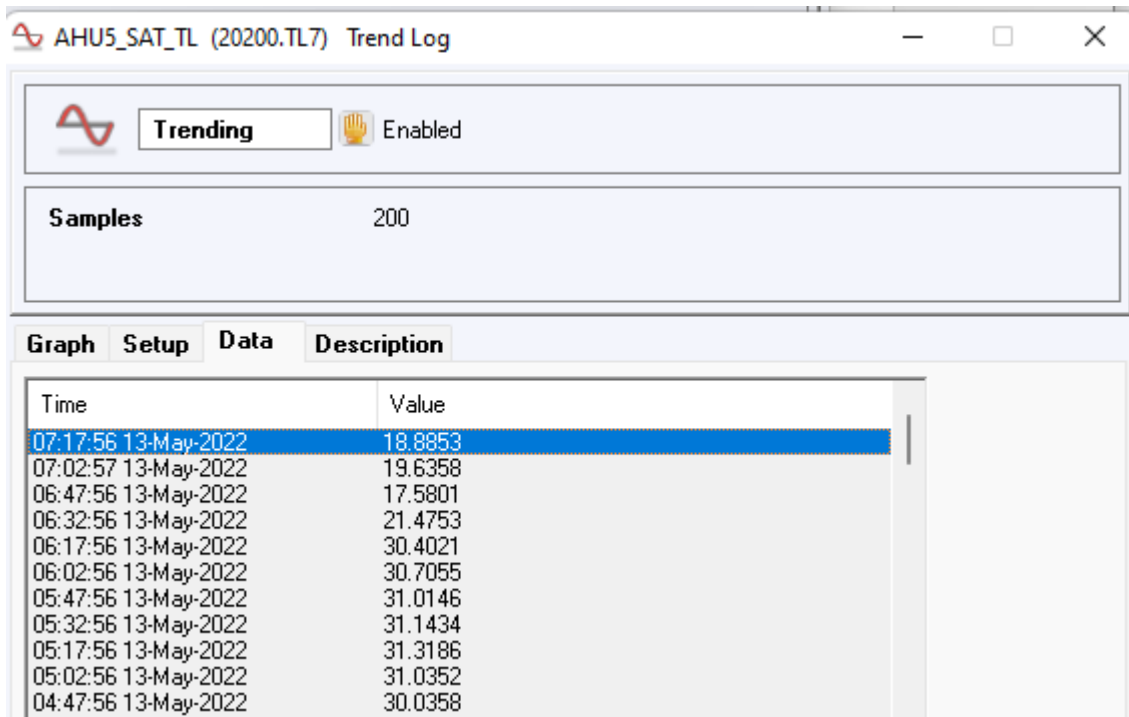

Figure 4: High supply air temperature overnight (before unit starts at 6:30am)

### 5.1.2 Measure Description

Validate the mixed air and supply air temperature sensor readings with a manual temperature reading in the field.

Operate the affected airhandlers with the supply fan enabled and the heating coil control valve commanded fully closed (0%). Manually measure the air temperature at the coil inlet and outlet. A temperature rise indicates a passing valve. Furthermore, the heating coil inlet and outlet pipes should be cold after the control valve is closed for several minutes.

Measure costs assume the control valve needs to be replaced.

### 5.1.3 Measure Implementation Update

[Provide confirmation details **AFTER** the measure is implemented and verified]

## 5.2 Measure 2: AHU-1 runs continuously

### 5.2.1 Description of Finding

AHU-1 was observed to run during its scheduled unoccupied period. Several different causes were identified during the investigation period.

#### Return fan feedback sensor

The return fan feedback sensor reports that the fan runs, even when commanded off. Figure 6 shows the supply fan is programmed to operate whenever the return fan's status is on. Figure 7 shows AHU-1 is programmed to operate its mixed air damper in occupied mode whenever the supply fan operates.

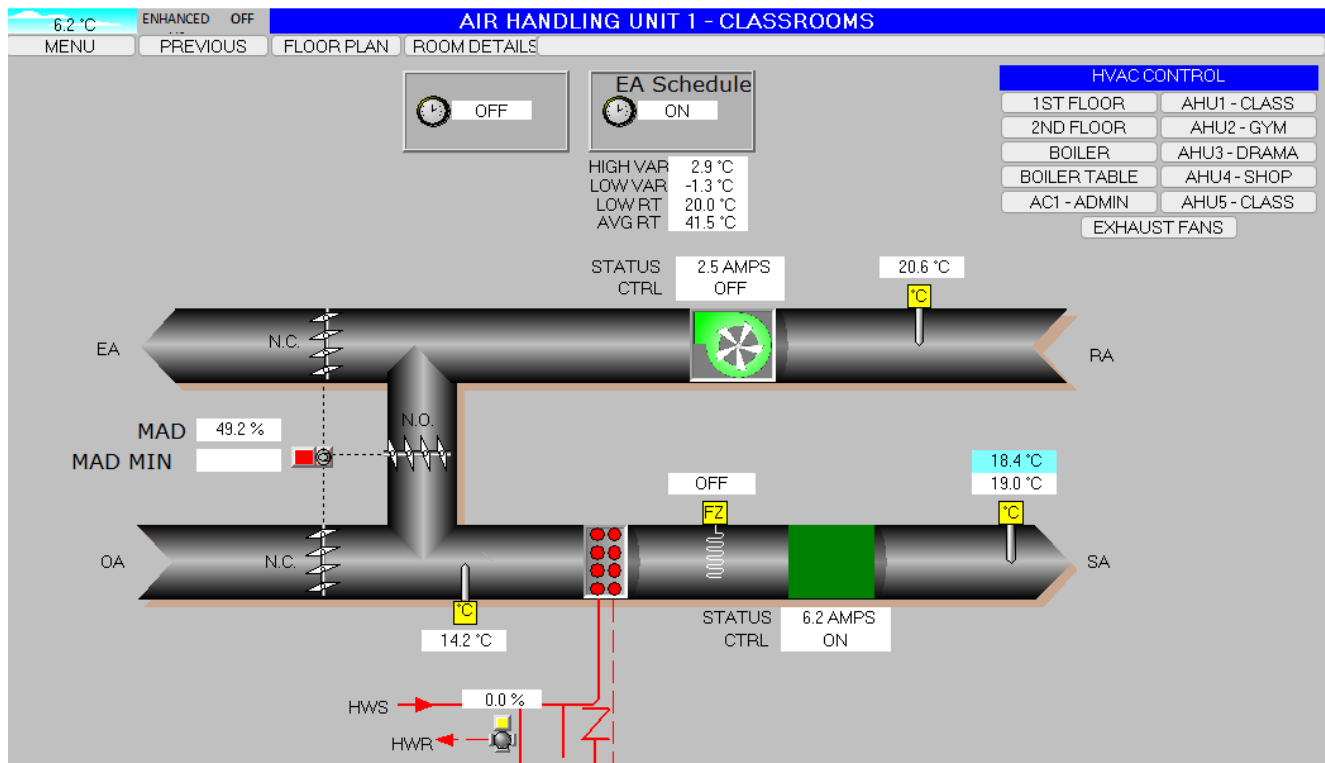

**Figure 5: AHU-1 runs with open mixed air dampers even when the main schedule is OFF**

```

49 ●
50 ● If (AHU1_RFS > 2) OnFor 10S Then
51 ● AHU1_SFC = 20301.AI2 = 2.46937 A
52 ● Else
53 ● AHU1_SFC = Off
54 ● End If
55 ●

```

**Figure 6: Return fan status enables the supply fan**

```

56 ● If AHU1_SFS > 5 Then
57 ● DoEver 20301.AI1 = 6.12943 A
58 ● AHU1_MAD_RAMP = Limit (AHU1_MAD_RAMP + (AHU1_RAT - 18), 0, 100)
59 ● End Do
60 ● AHU1_MAD_GV = (2 * AHU1_SAT_CO) - 100
61 ● AHU1_MAD_GV = Limit (AHU1_MAD_GV, 0, 100)
62 ● AHU1_MAD_GV = Max (AHU1_MAD_GV, AHU1_MAD_MIN)
63 ● AHU1_MAD_GV = Min (AHU1_MAD_GV, AHU1_MAD_LL_CO, AHU1_MAD_RAMP)
64 ●
65 ● If AHU1_NSB_GV On Then
66 ● AHU1_MAD_GV = 0
67 ● End If
68 ●
69 ● AHU1_HCV_GV = - 2 * AHU1_SAT_CO + 100
70 ● AHU1_HCV_GV = Limit (AHU1_HCV_GV, 0, 100)
71 ● Else

```

**Figure 7: Enabling the supply fan triggers normal damper and heating coil operation**

### Low room temperature calculation

AHU-1 is programmed to start during unoccupied hours if the lowest room temperature (*AHU1\_LOW\_RT*) is less than 16°C per Figure 9. However, the lowest room temperature is often a random negative value. This causes AHU-1 to run continuously.

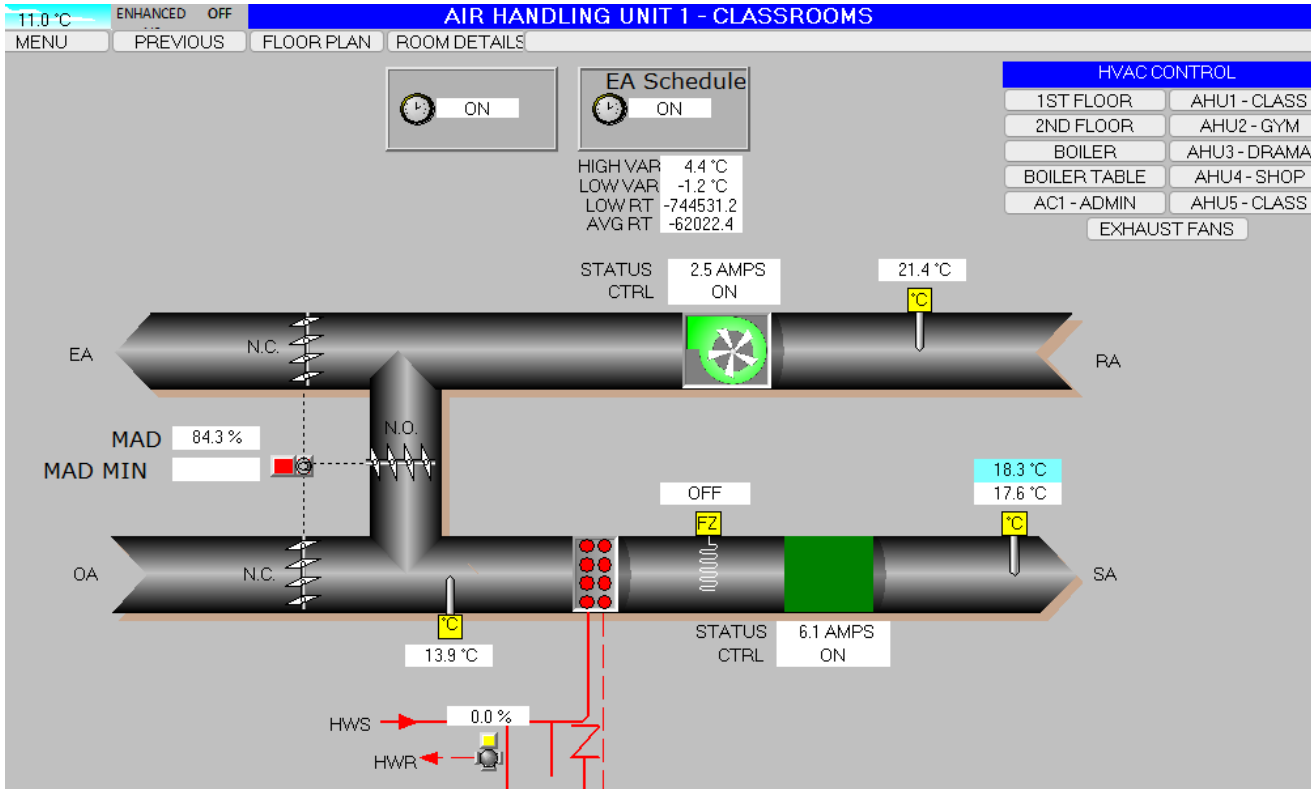

Figure 8: AHU-1 DDC Graphic

```

42 ● If AHU1_OCC On Then
43 ●   AHU1_RFC = On
44 ●   AHU1_NSB_GV = Off
45 ● Else
46 ●   AHU1_NSB_GV = Switch ( AHU1_NSB_GV, AHU1_LOW_RT, NSB_SP, NSB_SP + 1 )
47 ●   AHU1_RFC = AHU1_NSB_GV
48 ● End If
49 ●

```

20301.AV3 = -726819.1875 °C

Figure 9: The value of AHU1\_LOW\_RT is random (low negative number) which triggers night setback heating

### 5.2.2 Measure Description

Confirm whether the return fan responds correctly when commanded on and off. Confirm whether the feedback sensor correctly measures fan current. Replace the current sensor if necessary.

Replace any failed sensors used to calculate AHU1\_LOW\_RT and remove any sensors from its calculation that no longer exist.

### 5.2.3 Measure Implementation Update

[Provide confirmation details **AFTER** the measure is implemented and verified]

## 5.3 Measure 3: AHU-4 random operation

### 5.3.1 Findings

AHU-4 sometimes runs outside occupied hours, with no clear pattern.

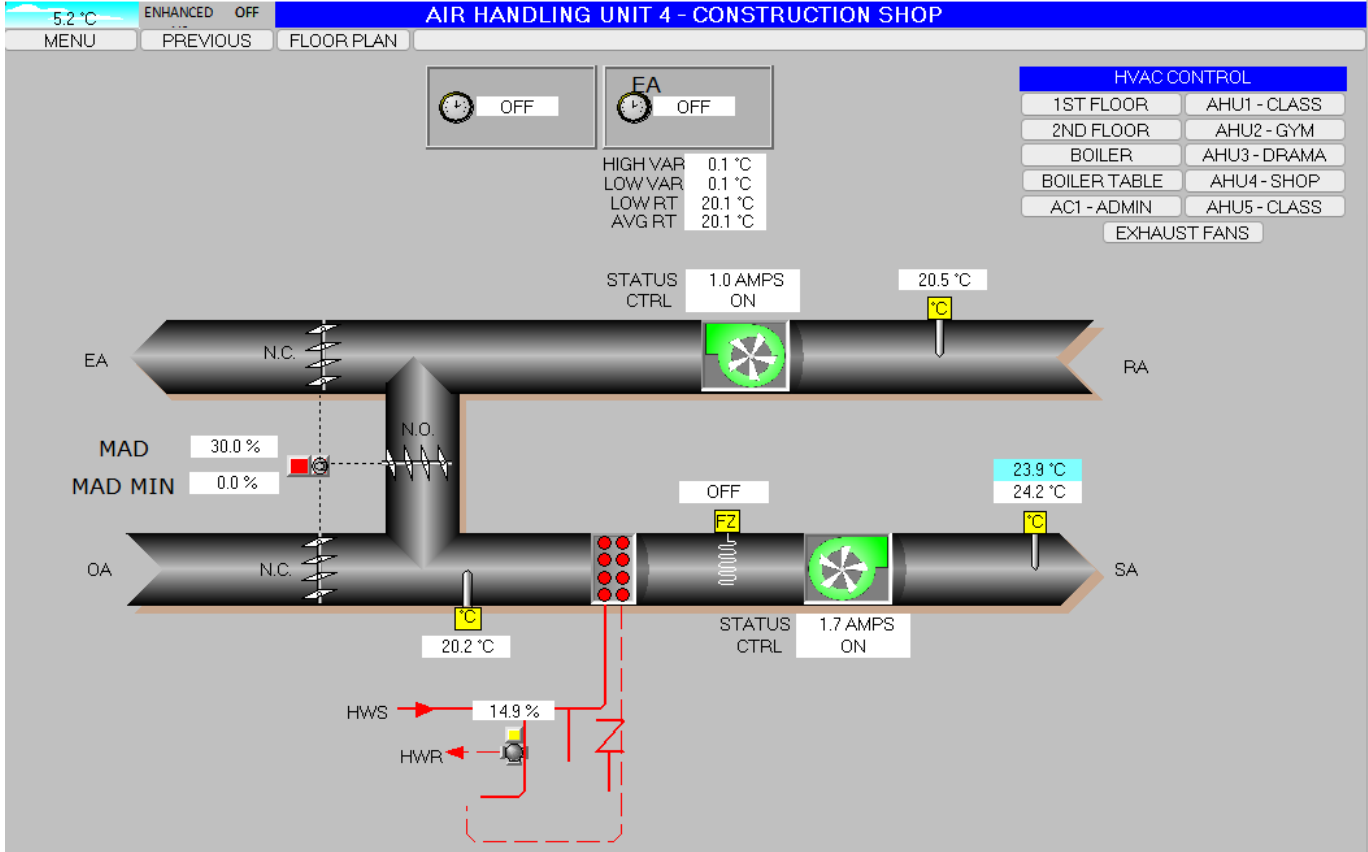

Figure 10: Operating schedule is OFF (Sunday) but AHU-4 is running.

Operation of AHU-4 is triggered by occupancy data from panel 20210 in room 169. However, this panel appears to be offline with undefined values, and the air handler operation does not match expected occupancy.

RM169\_OCC contains changing values and the value of 20210.Alg.Mode is "Object Undefined"

```

AHU4_PG (20201.PG4) Program
1 //AHU4 PROGRAM
2
3 AHU4_HI_VAR = Max (RM169_VAR)
4 AHU4_LO_VAR = Min (RM169_VAR)
5 AHU4_LOW_RT = Min (RM169_RT_AV)
6 AHU4_AVG_RT = Average (RM169_RT_AV)
7 AHU4_OCC = RM169_OCC
8

AHU4_ROOMS_PG (20201.PG5) Program
1 DoEvery 30S
2 RM169_RT_AV = 20210.Temperature
3 RM169_SP_AV = 20210.Setpoint
4 RM169_OCC = '20210.Alg.Mode'
5 RM1 | 20201.BV5 = ON RM169_RT_AV - RM169_SP_AV
6 // HEAT FROM AHU4 ONLY
7 End Do
    
```

Figure 11: AHU-4 occupancy determined by panel 20210

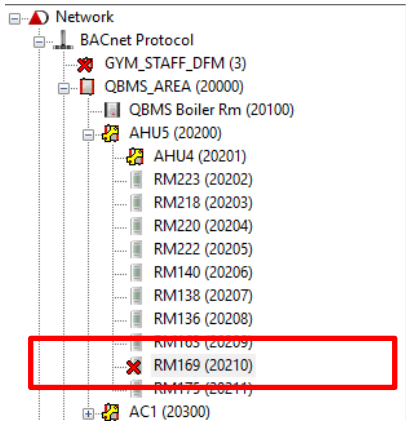

**Figure 12: Panel 20210 is offline**

### 5.3.2 Measure Description

Ensure Panel 20210 is correctly connected and that all control variables are available to other panels as required. Savings assume AHU-4 should run during regular class hours, but currently runs randomly (50% of all hours).

### 5.3.3 Measure Implementation Update

[Provide confirmation details **AFTER** the measure is implemented and verified]

## 5.4 Measure 4: Reheat valves blocked or passing

### 5.4.1 Description of Finding

The following reheat coil valves are suspected to be *passing* (discharge air temperature is higher than the supply air temperature from the air handler with the reheat coil valve commanded closed), or *blocked* (discharge air temperature close to the supply air temperature from the air handler with the reheat coil valve open).

**Table 5: Reheat issues**

Room / reheat	Air handler	Issue
RM123, RM127, RM129	AC-1	Blocked
RM107, RM108	AHU-3	Blocked
RM102, RM106	AHU-3	Passing

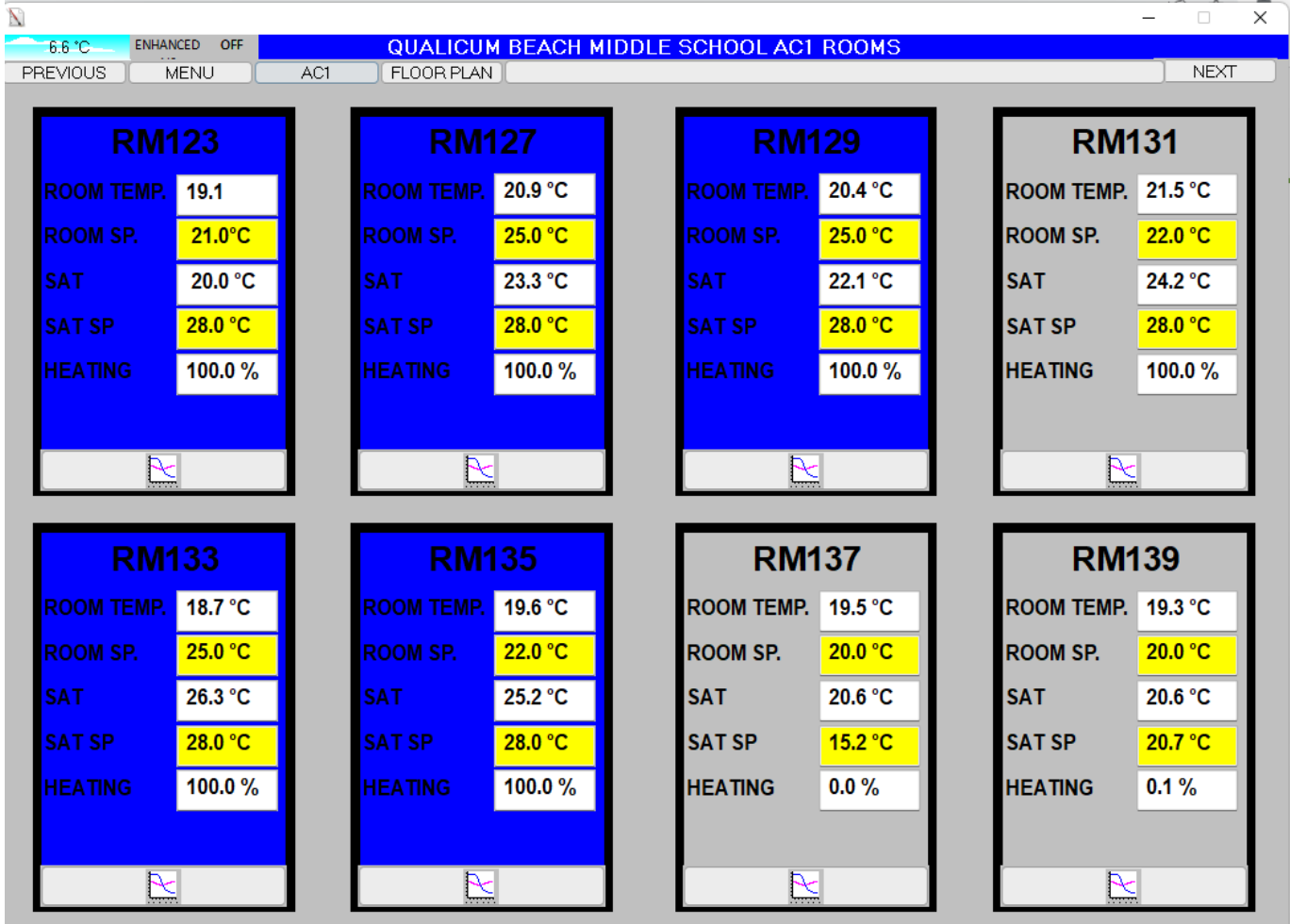

Figure 13: RM123 and RM129 reheat coils providing little or no heat. AC-1 supply air temperature was 21°C.



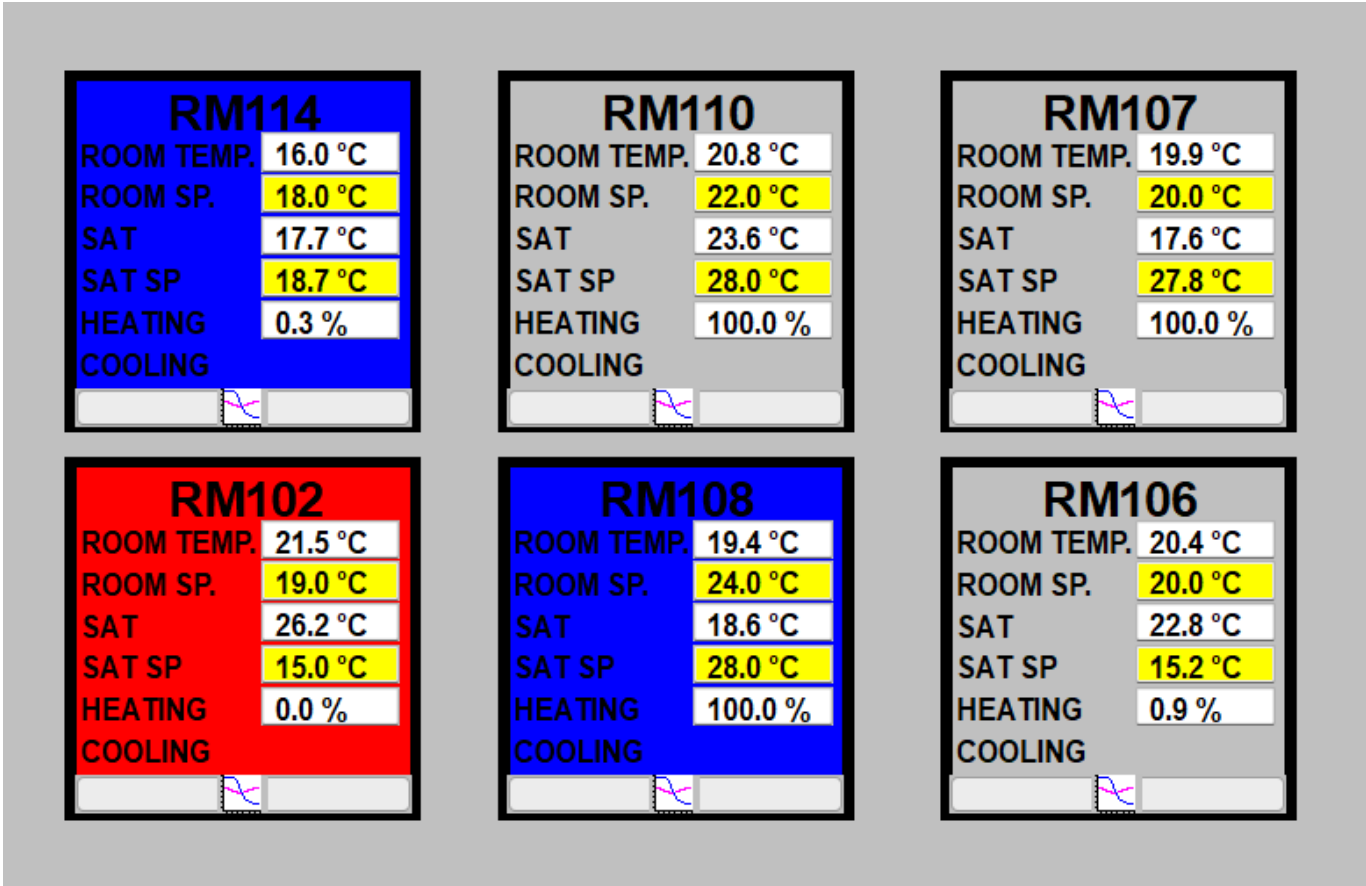

Figure 14: AHU-3 reheat coils. Little or no heat from RM107, RM108 reheats. RM102 and RM106 are heating even with valves at 0%. AHU-3 supply air temperature was 18.8°C.

The passing valve in room 102 is overheating the room. This causes AHU-3 to lower its supply air temperature setpoint and draw more outdoor air. This extra outdoor air needs to be reheated, increasing gas use.

### 5.4.2 Measure Description

Investigate the identified reheat coils:

- Confirm correct movement of the valve in positions from closed (0%) to fully open (100%).
- Confirm coils are clean and air flow matches design.

With boilers and air handler fans enabled:

- Close the valve fully, then confirm the vent discharge temperature matches the temperature of air supplied by the air handler, and that pipes leading to/from the coil warm quickly after the valve is closed.
- Open the valve fully, then confirm the pipes leading to/from the coil warm up, and that the air temperature rise over the coil matches specifications.

### 5.4.3 Measure Implementation Update

[Provide confirmation details **AFTER** the measure is implemented and verified]

## 5.5 Measure 5: Daily HVAC operation schedule

### 5.5.1 Description of Finding

The main HVAC schedule starts AC-1, AHU-1, AHU-3, and AHU-5 at 4am, Monday to Wednesday. On Thursday and Friday, the systems start at 7am, without any issues, which indicates that it should be possible to delay startup to 7am on the other days.

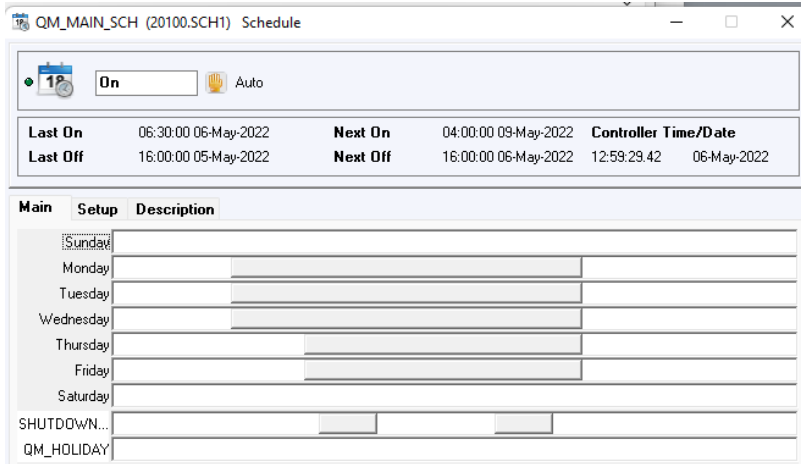

Figure 15: Main building operations schedule

### 5.5.2 Measure Description

Update the main building operations schedule (QM\_MAIN\_SCH) to start at 7am on all weekdays. Monitor room temperatures on Monday mornings, to determine if the Monday start time needs to be adjusted.

For further savings, the DDC can be programmed to adjust start times based on outdoor air temperature and room temperatures, since it takes more time to warm up the building on a cold morning than on a warmer day when the building has retained most of the heat from the previous day. This is commonly known as “optimal start”. The start time should be calculated separately for each air handler since they have different occupancy times.

### 5.5.3 Measure Implementation Update

[Provide confirmation details **AFTER** the measure is implemented and verified]

## 5.6 Measure 6: Summer HVAC operation schedule

### 5.6.1 Description of Finding

There is no evidence of a summer shutdown schedule for the HVAC system this year (2021) or in previous years.

Based on observation of the DDC system on 7 July 2022, the HVAC system maintains regular operation during the summer break. The occupancy of the school during this time is unknown, but it is assumed that it is largely unoccupied.

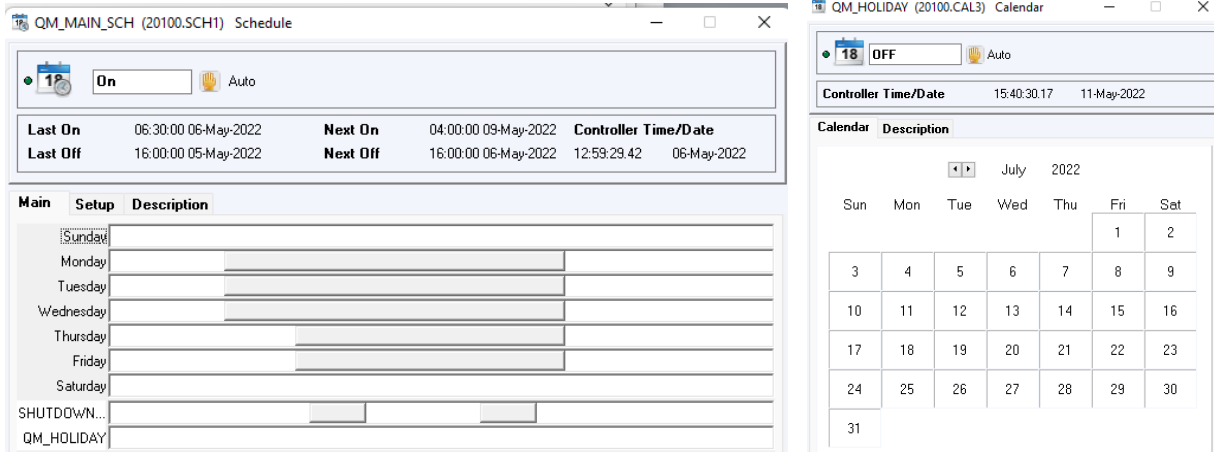

Figure 16: Main building operations schedule

### 5.6.2 Measure Description

Add summer shutdown days to the QM\_HOLIDAY schedule.

Define appropriate daily/weekly schedule to main schedule. For the sake of saving calculations, a two-hour morning flush during unoccupied holidays is assumed.

### 5.6.3 Measure Implementation Update

[Provide confirmation details **AFTER** the measure is implemented and verified]

## 5.7 Measure 7: DHW pumps run continuously

### 5.7.1 Description of Finding

The DHW recirculation pump control is overridden on in the DDC, causing it to operate continuously. Disabling the distribution pumps when the building is unoccupied would provide small electricity savings from reduced pump hours and gas savings from reduced distribution losses.

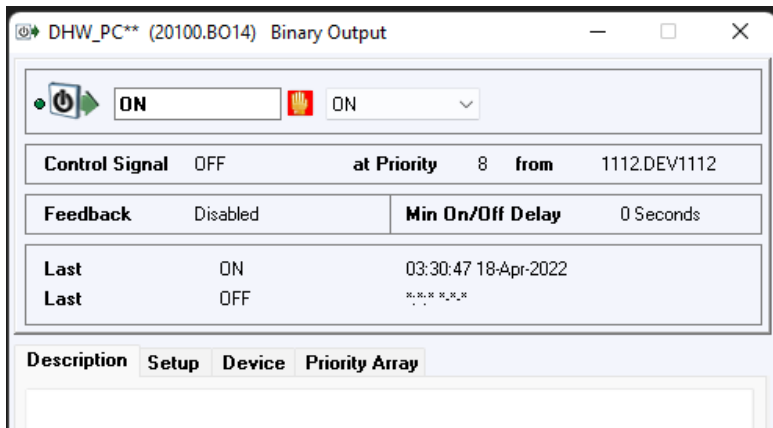

Figure 17: DHW recirculation pump override



### 5.7.1 Measure Description

Create a pump schedule to match occupancy, including custodial staff working outside regular occupancy hours. Remove manual override.

### 5.7.2 Measure Implementation Update

[Provide confirmation details **AFTER** the measure is implemented and verified]

## 5.8 Measure 8: Exhaust fan feedback

### 5.8.1 Description of Finding

The feedback sensor values for several exhaust fans do not match the fans' commanded state.

While this is likely due to sensor defects or calibration errors, the function of the fans should be investigated. Failed fans can cause indoor air quality issues. Exhaust fans operating continuously will use unnecessary electricity to spin the fan and gas from heating the infiltrated makeup air.

**Table 6: Mismatch between commanded state and feedback**

Fan	Room	Command	Feedback
EF-2	Storage (104,112)	Off	Running (16.3 Amps)
EF-4	Storage (116)	Off	Running (16.9 Amps)
EF-9	Main washrooms	On	Not running (0 Amps)
EF-19	Rm 169	On	Not running (0 Amps)

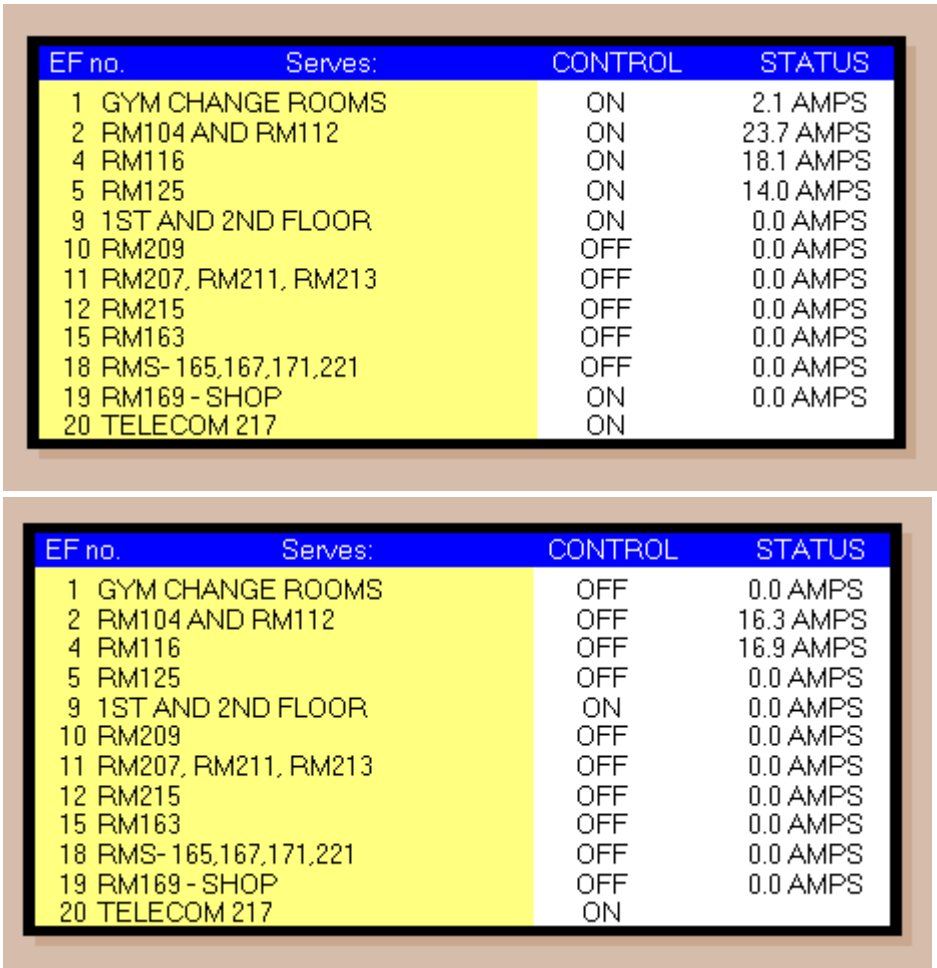

Figure 18: Exhaust fans at different times

### 5.8.2 Measure Description

Confirm in the field whether each exhaust fan operates when commanded and if the status aligns with its actual state.

### 5.8.3 Measure Implementation Update

[Provide confirmation details **AFTER** the measure is implemented and verified]

## 5.9 Measure 9: AHU-4 damper issue

### 5.9.1 Description of Finding

AHU-4 mixed air temperature equals return air temperature in Figure 19 despite a 30% open mixed air damper. This suggests the dampers are not functioning, and the RM 169 Construction Shop served by AHU-4 is not getting any outdoor air. This reduces indoor air quality and cooling, reducing occupant comfort.

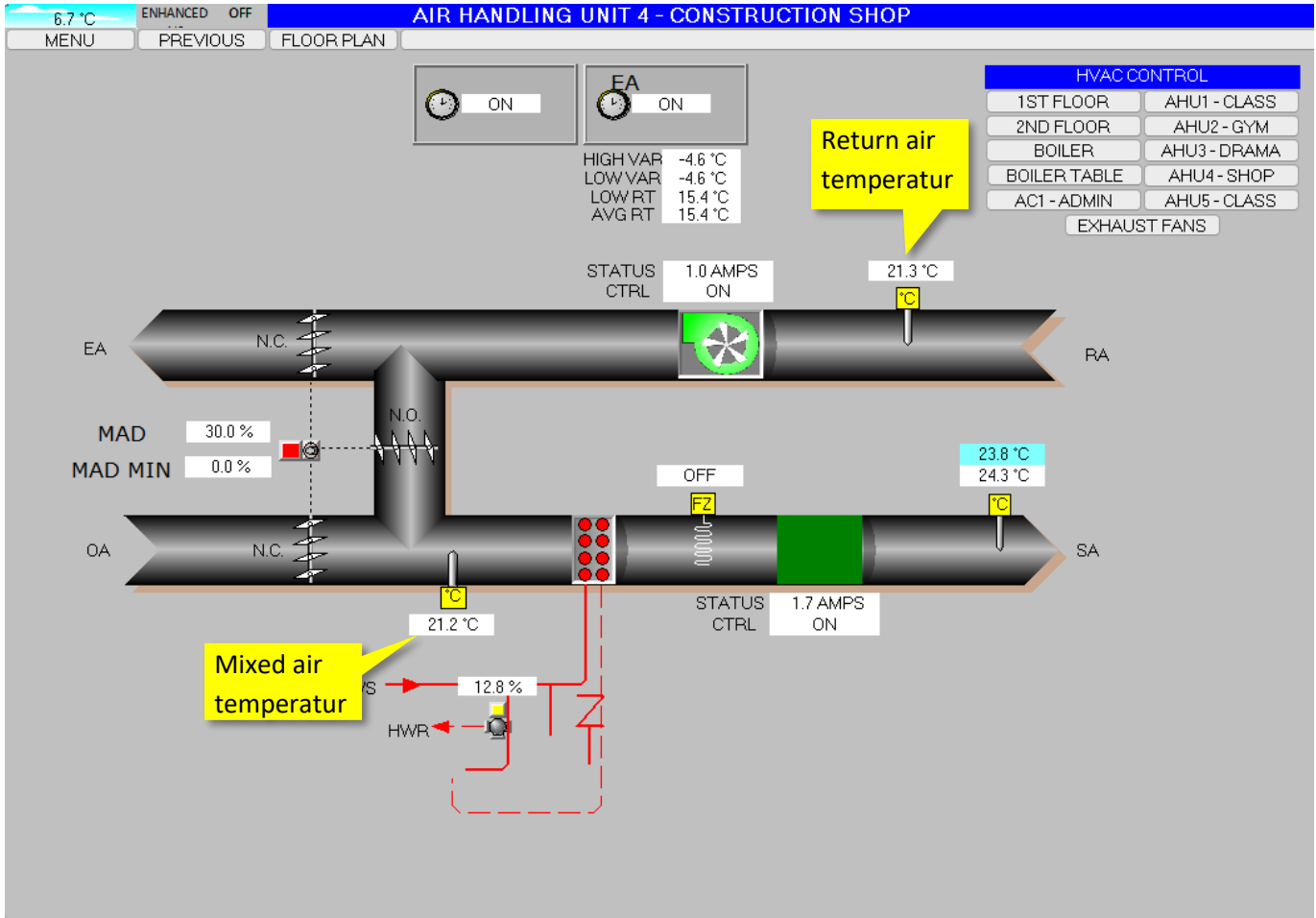

Figure 19: AHU-4 with RAT equal MAT

### 5.9.2 Measure Description

Visually confirm the AHU-4 dampers operate when commanded to various positions. Check for obstructions to the outdoor air supply.

Measure costs are for replacing one damper actuator.

There are no energy savings for this measure.

### 5.9.3 Measure Implementation Update

[Provide confirmation details **AFTER** the measure is implemented and verified]

## 6.0 Measures to be considered for Future Implementation

This section provides an overview of each measure (that was identified but **was not selected** as part of this C. Op. project, but maybe considered for future implementation), recommendations for implementation, and the most suitable method for providing evidence of implementation. See Appendix A - Investigation Phase Summary Table for more details.

### 6.1 *Measure 10: Replace AC-1 condensing unit with air-to-water heat pump*

AC-1's condensing unit is original to the building (2002) and at the end of its predicted service life. It could be replaced by a reversible air-to-water heat pump. The heat pump could be connected to the existing heating coils in AC-1 and the three other air handlers on the roof. During winter, the heat pump would operate in heating mode, and provide 1<sup>st</sup> stage heating to the four air handlers. When required, additional heat would be supplied from the existing boiler loop.

During summer, the heat pump and air handlers could be isolated from the rest of the boiler loop, and the heat pump would provide chilled water to AC-1, with either the existing coil, or a new larger coils serving as a switchover coils. Cooling could also be provided to the other nearby air handlers if desired<sup>1</sup>, but this would require a larger heat pump at a higher project cost.

Estimated costs include all work required to replace the condensing unit with a heat pump. While a heat pump installation is likely to be more expensive than like-for-like replacement of the condensing unit, it is more cost effective than installing both a new condensing unit and a separate heat pump. If the heat pump is sized similarly to the existing condensing unit (20 Tons), it would be able to operate on the existing electrical circuit.

A feasibility study is recommended as the next step to assessing the viability of this project and alternatives. Heating water supply temperatures, and heating coil operation for the four impacted air handlers should be trended through the heating season to confirm savings potential. Mechanical and structural assessments are required to refine the cost and viability of the project.

---

<sup>1</sup> This help achieve any climate resilience goals that require managing extreme heat events.

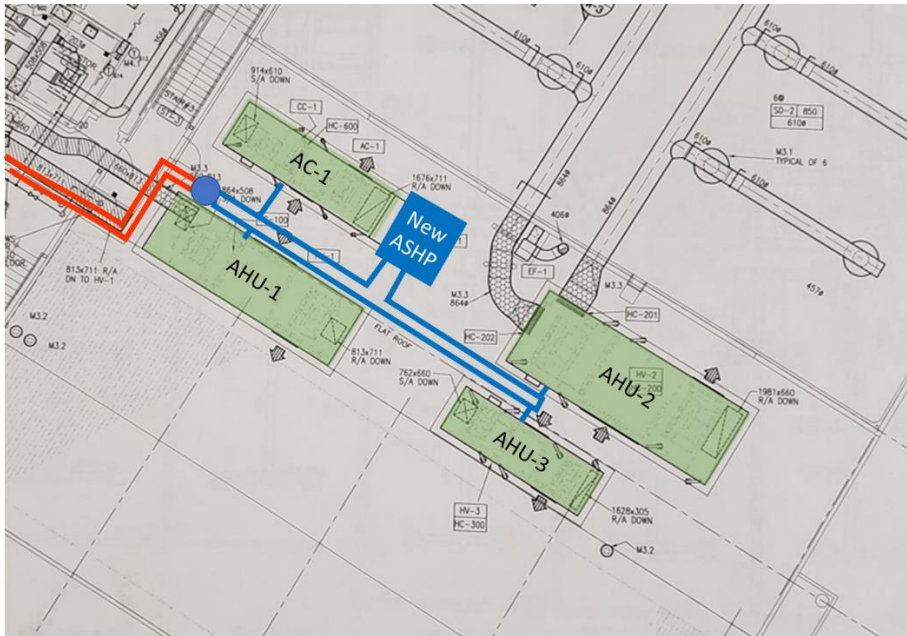

Figure 20: Possible location of ASHP on roof with new loop

## 6.2 Measure 11: Air source heat pump connected to boiler plant

The boiler supply temperature setpoint was observed to reset to low temperatures (50°C or below) at moderate outdoor temperatures (4°C and above), and the supply water temperature could likely be adjusted even lower. This makes the building a potential candidate for connecting an air source heat pump to the hydronic loop.

One possible location for an air-source heat pump would be in the gated storage/dust-collector area next to the construction classroom. Alternatively, any location near the school might suffice with fencing around the heat pump. It may also be possible to install the heat pump in the mechanical room, with outdoor air ducted through the heat pump.

During winter, the heat pump would operate in heating mode, and provide 1<sup>st</sup> stage heating to all heating coils in the building, with supplemental heating from the boiler plant. During colder periods, when the heating system requires higher water temperatures than what the heat pump can produce, the system would switch to full gas heating mode.

Estimated costs include all work required to install a new heat pump in the storage area. Alternative locations would involve higher costs. The need or cost for an electrical service upgrade has not been evaluated.

A feasibility study is recommended as the next step to assessing the viability of this project. Heating water supply temperatures, and heating coil performance should be trended through the heating season to confirm the heat pump could operate for most of the heating season. Mechanical and structural assessments are required to refine the cost and viability of the project.



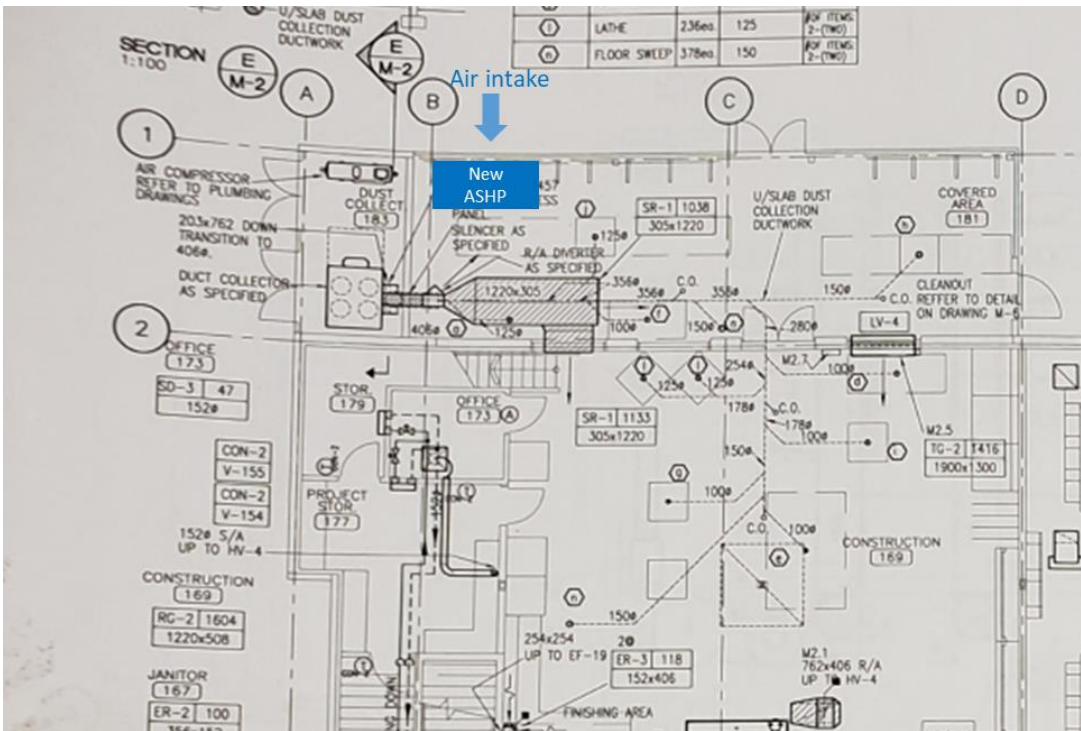

Figure 21: Possible location for ASHP in the covered storage/dust collector area



**Figure 22: Possible alternative locations for an air-source heat pump connected to the heating loop**

## 7.0 Next Steps – Implementation Phase and Completion Phase

### 7.1 Implementation Phase

To continue in the program, the owner is responsible for implementing the selected bundle of measures that pay back in two years or less. Using the *Recommissioning Report* for implementation allows flexibility in how the selected measures are implemented. Options include: utilize in-house building staff, hire the C.Op Provider to implement or provide technical assistance, contract with outside service contractors, or any combination of the above.

### 7.2 Completion Phase

C.Op Service provider will follow up after implementation of the selected measures and **update** this *Recommissioning report and Recommissioning Workbook*.

The updated report for the implemented measures includes but not limited to: date of completion of each measure, new or improved sequences of operation, the energy savings impact of the measures, the requirements for ongoing maintenance and monitoring of the measures, and contact information for the service provider, in house staff, and contractors responsible for the implementation. When feasible, verification data should include trends or functional test results, though other methods, such as copies of invoices, site visit reports, and before/after photos, may be acceptable.

The C.Op Service Provider will conduct an in-house (teleconference) session for the Applicant and the appropriate building operations personnel covering the new documentation, measures that were implemented, and requirements for ongoing maintenance and monitoring. Document the attendance of the building operations staff.

The *updated Recommissioning Workbook* and *updated Recommissioning Report* will be submitted to the owner and the program for review. See Appendix B: Completion Phase Summary Table for more details on implemented measures.

## Appendix A: Investigation Phase Summary Table

Investigation Phase Summary				Investigation Phase							
ECM #	Measure Title	Measure History	Include cost	Energy Savings			Cost Savings	Financial		Est. GHG Reduction	Enter "x" if DESELECT for implementation
				Demand (kW)	Electrical (kWh/yr)	Fuel (GJ)	Total (\$/yr)	Estimated Measure Cost (\$)	Simple Payback (yrs)	tonnes CO2e/yr	
ECM-1	AHU heating coil valve passing	New	1	-	-	467	\$ 5,666	\$ 9,500	1.7	23.3	
ECM-2	AHU-1 runs continuously	New	1	-	64,275	120	\$ 7,793	\$ 800	0.1	6.7	
ECM-3	AHU-4 random operation	New	1	-	26,282	22	\$ 2,854	\$ 700	0.2	1.4	
ECM-4	Reheat valves blocked or passing	New	1	-	-	58	\$ 698	\$ 4,800	6.9	2.9	
ECM-5	HVAC daily schedule	New	1	-	15,362	58	\$ 2,218	\$ 400	0.2	3.1	
ECM-6	HVAC summer schedule	New	1	-	13,452	-	\$ 1,326	\$ 600	0.5	0.1	
ECM-7	DHW pumps run continuously	New	1	-	627	23	\$ 335	\$ 600	1.8	1.1	
ECM-8	Exhaust fan feedback	New	1	-	-	-	\$ -	\$ 1,100	#DIV/0!	-	
ECM-9	AHU-4 damper issues	New	1	-	-	-	\$ -	\$ 1,000	#DIV/0!	-	
ECM-10	Replace AC-1 condensing unit with air-to-w	New	1	-	62,440	635	\$ 1,543	\$ 284,614	184.5	31.0	x
ECM-11	ASHP connected to boiler plant	New	1	-	73,756	809	\$ 2,537	\$ 307,151	121.1	39.6	x
TOTAL (Previous, still working):				-	-	-	\$ -	n/a	n/a	-	
TOTAL (All potential measures for Implementation):				-	16,198	2,191	\$ 24,969	\$ 611,265	24.5	109.1	
TOTAL (Selected measures only):				-	119,998	748	\$ 20,889	\$ 19,500	0.9	38.6	

Implementation cap @\$0.25/ft2 \$ 13,280

## Appendix B: Completion Phase Summary Table

[Paste image of Completion Summary Table from the RCx Workbook AFTER Implementation]

## Appendix C: Sample Training Outline

### [Completion Report AFTER Implementation]

The Commissioning Provider (C.Op Provider) may customize the outline for the training and developing the training materials. Before preparing the training outline and materials, the C.Op Provider should assess the related level of knowledge of the building operators, to set up the training accordingly. For reference, the Program provides the following sample outline for the training:

- Background on the energy use of this particular building
  - Present Energy Utilization Index
  - Describe Operating Schedules and Owner's operating requirements
- RCx investigation process used in this building
  - Describe the methods used to identify problems and deficiencies
  - Review the RCx Workbook
- Implementation process in this building
  - Describe the measures that were implemented and by whom
  - Walk around the building to look at any physical changes or step through the new control sequences at the operator workstation
  - Provide as many details about implementation as necessary to describe what was done
  - Describe improved performance that these measures will create (show trends if available)
- O&M requirements
  - Describe the O&M requirements needed to keep these improvements working
  - Describe how the staff can be aware of energy efficiency opportunities and begin looking for additional savings potential

The C.Op Provider should follow the outline to prepare materials, as necessary, to hand out at the training session.



## Appendix D: Training Completion Form

Project ID
------------

### Facility Information

Company Name	Building Name(s)
Facility Address	City Province

### Training Details

Location	Date
Commissioning Provider/Trainer	

### Materials Attached

<input type="checkbox"/> Agenda
<input type="checkbox"/> Materials used for training
<input type="checkbox"/> List of individuals who attended

### COMMISSIONING PROVIDER SIGNATURE

By signing this Training Completion Form, I verify that this training took place with the listed attendees.	
Commissioning Provider (print name):	
Signature:	Date:

**FACSIMILE/SCANNED SIGNATURES:** Facsimile transmission of any signed original document, and the retransmission of any signed facsimile transmission, shall be the same as delivery of the original signed document. Scanned original documents transmitted to BC Hydro as an attachment via electronic mail shall be the same as delivery of the original signed document. At the request of BC Hydro, C.Op Provider shall confirm documents with a facsimile transmitted signature or a scanned signature by providing an original document.



Targeted Documentation

O & M Manual

O & M Manual updated <input type="checkbox"/>	Describe updates below and attach copies of new or amended portions
O & M Manual not updated <input type="checkbox"/>	Province reasons below
Building has no O & M Manual <input type="checkbox"/>	

Building Plans (“as-builts”)

Building Plans updated <input type="checkbox"/>	Describe below
Wiring diagrams updated <input type="checkbox"/>	Describe below
No plans or diagrams updated <input type="checkbox"/>	Describe below

EMS Programming

New sequences of operation on file <input type="checkbox"/>	Specify location of file and attach copy
Printed screenshots on file <input type="checkbox"/>	Specify location of file and attach copy

Equipment Manuals





Manuals for new equipment are on file <input type="checkbox"/>	Describe below (attach copy if applicable)



Checklist of subjects discussed at training

Explain investigation process and how measures were identified	<input type="checkbox"/>
Describe implemented measures, and how they are reducing energy usage	<input type="checkbox"/>
Building walkthrough to show implemented measures	<input type="checkbox"/>
Describe methods for monitoring and maintaining optimum system performance related to implemented measures	<input type="checkbox"/>
Describe scenarios where system setting changes would be required, and how to maintain optimum energy efficiency, e.g., seasonal-based manual adjustments to setpoints.	<input type="checkbox"/>



**List of Individuals Who Attended**

Name	Title	Building (address or name)	Contact information (e-mail and/or phone number)



Continuous Optimization for Commercial Buildings Program

# Recommissioning Report

---

Version	Updated on	Phase
1	July 12, 2021	Investigation

Prepared for:

School District 69

Springwood Elementary School

450 Despard Ave W

Parksville, BC

Project: BCH-07833

Prism Project: 2021300

---

Prepared by:

Prism Engineering Ltd.

#320 - 3605 Gilmore Way

Burnaby, BC





# TABLE OF CONTENTS

<b>1.0</b>	<b>INTRODUCTION .....</b>	<b>3</b>
<b>2.0</b>	<b>PROJECT OVERVIEW .....</b>	<b>4</b>
<b>3.0</b>	<b>SAVINGS SUMMARY .....</b>	<b>5</b>
<b>4.0</b>	<b>BRIEF DESCRIPTION OF EXISTING SYSTEM .....</b>	<b>6</b>
4.1	FACILITY DESCRIPTION .....	6
4.2	HEATING SYSTEM .....	7
4.3	COOLING SYSTEM .....	9
4.4	VENTILATION SYSTEM .....	9
4.5	DOMESTIC HOT WATER SYSTEM .....	10
4.6	CONTROLS SYSTEM .....	10
<b>5.0</b>	<b>MEASURES SELECTED FOR IMPLEMENTATION (UNDER C.OP. PROGRAM) .....</b>	<b>11</b>
5.1	MEASURE 1: AHUs RUNNING OVERNIGHT .....	11
5.2	MEASURE 2: AHU SCHEDULES .....	15
5.3	MEASURE 3: SUMMER SCHEDULES .....	16
5.4	MEASURE 4: BOILER TEMPERATURE OVERRIDDEN TO 60°C .....	17
5.5	MEASURE 5: AC-2 VALVE AND DAMPER CONTROL .....	18
5.6	MEASURE 6: INEFFECTIVE REHEAT COILS .....	19
5.7	MEASURE 7: HV-5 BROKEN SAT SENSOR .....	21
5.8	MEASURE 8: HV-2 RF NOT RUNNING WHEN SF IS AT 40% .....	21
5.9	MEASURE 9: AC-1 MIXED AIR TEMPERATURE IS HIGHER THAN EXPECTED .....	22
<b>6.0</b>	<b>MEASURES TO BE CONSIDERED FOR FUTURE IMPLEMENTATION .....</b>	<b>24</b>
6.1	MEASURE 10: REPLACE CHILLER WITH REVERSIBLE HEAT PUMP .....	24
<b>7.0</b>	<b>NEXT STEPS – IMPLEMENTATION PHASE AND COMPLETION PHASE .....</b>	<b>25</b>
7.1	IMPLEMENTATION PHASE .....	25
7.2	COMPLETION PHASE .....	25
<b>APPENDIX A:</b>	<b> INVESTIGATION PHASE SUMMARY TABLE .....</b>	<b>26</b>
<b>APPENDIX B:</b>	<b> COMPLETION PHASE SUMMARY TABLE .....</b>	<b>27</b>
<b>APPENDIX C:</b>	<b> SAMPLE TRAINING OUTLINE .....</b>	<b>28</b>
<b>APPENDIX D:</b>	<b> TRAINING COMPLETION FORM .....</b>	<b>29</b>

## 1.0 Introduction

Prism Engineering is pleased to present the results of the Investigation Phase that was conducted as part of BC Hydro's Continuous Optimization for Commercial Buildings Program for School District 69. The objective of an Investigation is to identify deficiencies and improvements in the operation of a facility's mechanical equipment, lighting, and related controls, and determine opportunities for corrective action that reduce energy consumption and preserve the indoor environmental quality.

This document is a complete record of the work performed at this facility, including the in-depth investigation of the building systems and the implementation of selected measures to optimize building performance.

The Recommissioning Investigation Report provides an overview of the recommendations for the implementation of measures. This information is not considered a specification or detailed sequence of operations. The intent is to provide an overview of the recommendation that can be built upon during the implementation phase as part of any detailed design that may be required. Certain measures may require further investigation and specification for the correct implementation by the owner or the DDC contractor.

Nine recommended retrofits were identified as a part of this investigation. The proposed measures will be reviewed in a meeting with SD69 and Prism Engineering representatives to determine which measures will be implemented.

Recommended retrofits for implementation include:

- Measure 1: AHUs running overnight
- Measure 2: AHU Schedules
- Measure 3: Summer schedules
- Measure 4: Boiler temperature override
- Measure 5: AC-2 valve and damper control
- Measure 6: Ineffective Reheat Coils
- Measure 7: Broken HV-5 SAT sensor
- Measure 8: HV-2 return fan not running when SF is at 40%
- Measure 9: AC-1 mixed air temperature

These measures are presented in the Investigation Summary Table (see Appendix A).

While the investigation focuses on low-cost improvements with short paybacks, some capital improvement opportunities may also be identified. Major retrofit measures are beyond the scope of this program, but other BC Hydro and FortisBC programs provide a variety of incentives to complete the retrofits. Retrofits were identified as a part of this investigation that could potentially qualify for other BC Hydro and FortisBC programs, these measures are described in Section 6.

Retrofits include:

- Measure 10: Replace chiller with reversible heat pump



## 2.0 Project Overview

<b>Project Information</b>		<i>Complete cells this background colour</i>			
RCx Project File #	<b>BCH-07833</b>				
Date of Workbook Update	12-Jul-2022				
Organization	School District 69				
Building Name	Springwood Elementary School				
Building Type	Large School				
Location (City)	Parksville, BC				
Owner Contact	Phil Munro				
Investigation Phase start date	01-Feb-2022				
Participated in previous BCH RCx program?	No				
Previous RCx File #					
Previous RCx completion date					
<b>Building Information</b>					
Facility Area (ft <sup>2</sup> )	56,694				
Annual elec consumption (kWh)	309,465	5.5		kWh/ft <sup>2</sup>	
Annual elec costs (\$)	\$ 30,487	\$ 0.10		Avg. \$/kWh	
Fuel type	Natural Gas				
Annual fuel consumption (GJ)	1,199	5.9		ekWh/ft <sup>2</sup>	
Annual fuel cost (\$)	\$ 14,535	\$ 12.1		Avg. \$/GJ	
Total GHG emissions (tCO <sub>2</sub> e/yr)	63				
Total Energy Cost	\$ 45,023	\$ 0.79		\$/ft <sup>2</sup>	
Energy Use Intensity (ekWh/ft <sup>2</sup> )	11.3				
Year for energy data above	2021				



### 3.0 Savings Summary

Savings Summary	Previous, still working	New + Previous, rectify + Previous, documented					
		Identified		Selected		Implemented	
	# of measures	10		9		9	
		Re-claim Savings	Total Savings	% Savings	Total Savings	% Savings	Total Savings
Electrical savings (kWh/yr)	-	102,019	33.0%	170,450	55.1%	170,450	55.1%
Fuel savings (GJ/yr)	-	983	82.0%	171	14.3%	171	14.3%
Cost savings (\$)	\$ -	\$ 21,971	48.8%	\$ 18,867	41.9%	\$ 18,867	41.9%
GHG reduction (tCO2e/yr)	-	50.1	79.4%	10.4	16.4%	10.4	16.4%
<b># of Abandoned measures</b>	<b>0</b>						





## 4.0 Brief Description of Existing System

This section contains a brief description of the existing HVAC and Controls system. The information is intended to provide a general overview only.

### 4.1 Facility Description

The Springwood Elementary School was built in 1996 and has a floor area of 56,694 sqft. The building contains classrooms, admin offices, gym, library, music room, and technical teaching spaces.

**Table 1: Occupancy Schedule**

Area	Days	From	To
Classrooms	All schooldays	8:55am	2:45pm
Office hours	All schooldays	8:00am	3:30pm

**Table 2: Operating Schedules**

Area	Days	From	To
Main equipment schedule	Mon/Tue/Thu/Fri	6:30am	3:30pm
	Thursday	6:30am	9:30pm
DHW	Monday-Friday	6am	9pm
AC-1	Monday-Friday	6am	3:30pm (9pm Thu)
HV-1, HV-5	Monday-Wednesday	4am	4:30pm
	Thursday-Friday	7am	4:30pm
	Monday and Friday	6pm	7pm
HV-2, HV-3, HV-4, AC-2	Monday-Wednesday	4am	4pm (9pm Tue)
	Thursday-Friday	7am	4pm
	Mon/Fri (HV-3 only)	6pm	7pm

Outside occupied hours, air handlers run when required to maintain room temperatures. During occupied hours, boilers are enabled when outdoor air temperature is below 15°C. Outside occupied hours, the boilers operate when outdoor air is below 12°C.

## 4.2 Heating System

Heat is provided by five 399 MBH (input) IBC condensing gas boilers. Boilers B-2 to B-5 heat a secondary loop through a low loss header. Boiler B-1 can either heat domestic hot water through a heat exchanger or supplement building heating, per the current requirements of the building.

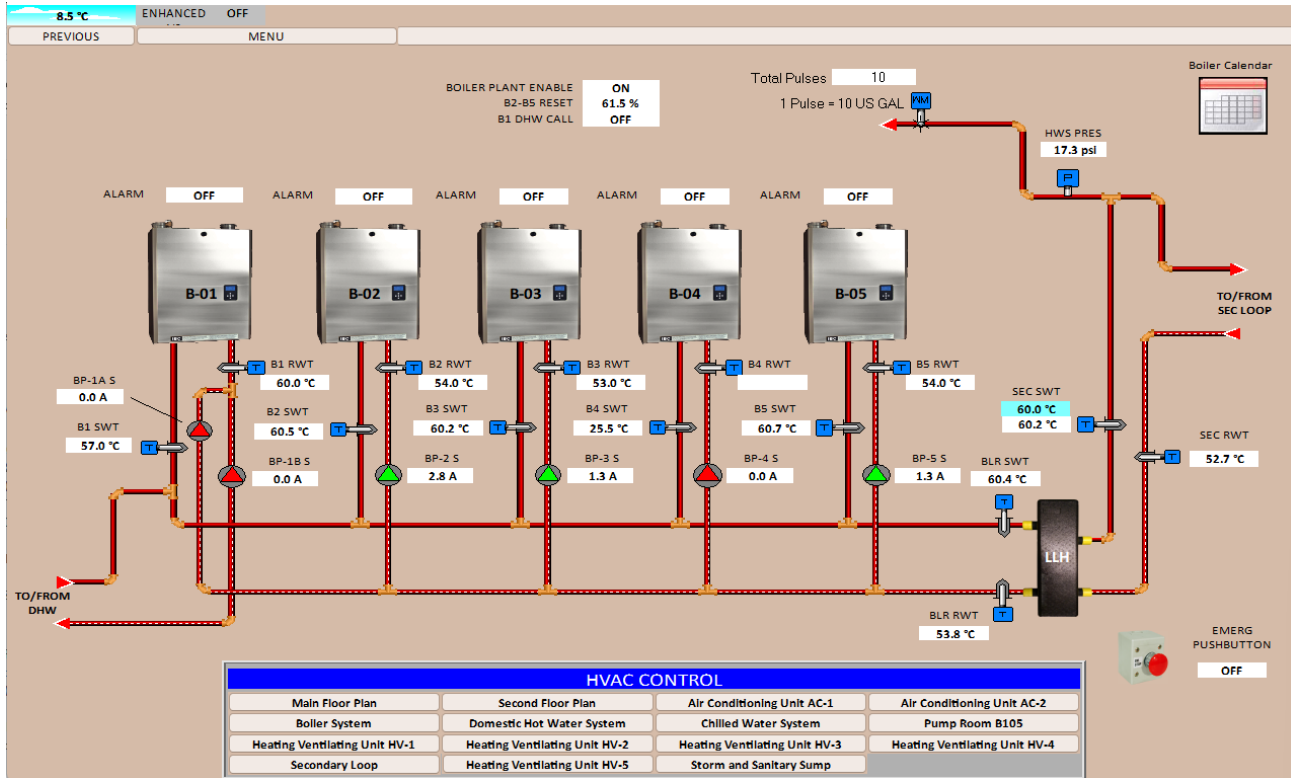

Figure 1: Boiler plant in the DDC



**Figure 2: B-1 supplies both DHW and space heating via two boiler pumps**

The heating water supply temperature setpoint was manually set to 60°C when observed during Prism’s study. Heating water is distributed to several air handlers, room terminal reheat coils, fan coil units, and radiators.

**Table 3: Heating Water Pumps**

Tag	Serves	Size	VSD	Flow	Head
BP1A	Boiler Pump from B-1 to DHW heat exchanger	Unknown	No	Unknown	Unknown
BP1B to BP5	Boiler Pumps for space heating	Unknown	No	Unknown	Unknown
P-1	Secondary loop to building	3 HP	Yes	12.62 l/s	108 kPa
P-HCHV2	HV-2 heating coil	335 W	No	0.63 l/s	79.2 kPa
P-HCHV3	HV-3 heating coil	335 W	No	0.60 l/s	79.3 kPa
P-HX1	DHW heat exchanger to storage tank	Unknown	Unknown	Unknown	Unknown
P-DHWR	DHW building circulation	265 W	No	Unknown	Unknown

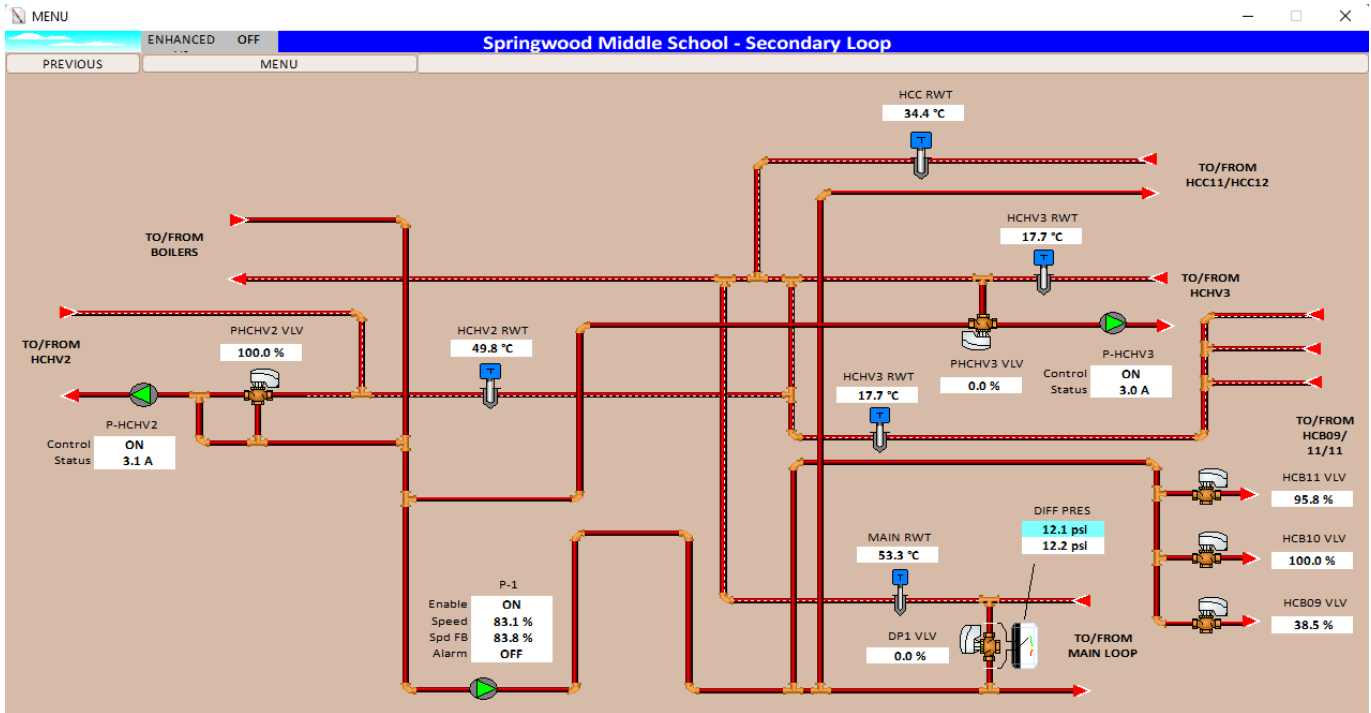

Figure 3: Secondary loops

### 4.3 Cooling System

Cooling is provided by a chiller which serves cooling coils in air handlers AC-1 and AC-2.

The chiller was manually disabled during the investigation phase. The DDC is programmed to enable the chiller when the outdoor temperature exceeds 15°C and AC-1 or AC-2 request cooling.

### 4.4 Ventilation System

Ventilation is provided by the air handlers show in in Table 4.

Table 4: Air handlers

Tag	Service	Airflow	Supply Fan	Return Fan	Coils	Outdoor Air
AC-1	Administration	3698 l/s	10 HP Constant speed	5 HP	Cooling	Mixed Min 30% OA
AC-2	Tech C110	944 l/s	3HP Constant speed	-	Heating, Cooling	Mixed Min 30% OA
HV-1	Multi-purpose. Music.	6110 l/s	10 HP Constant speed	5 HP	None	Mixed Min 20% OA
HV-2	Gymnasium	7792 l/s	10 HP Variable speed	5 HP Variable speed	Heating	Mixed Min 30% OA

Tag	Service	Airflow	Supply Fan	Return Fan	Coils	Outdoor Air
HV-3	Block A Classrooms	9812 l/s	20 HP Constant speed	7.5 HP	Heating	Mixed Min 30% OA
HV-4	Construction	944 l/s	3 HP	-	Heating	Mixed Min 30% OA
HV-5	Boiler Room	590 l/s	¾ HP	-	None	Mixed

### 4.5 Domestic Hot Water System

Domestic hot water is heated by B-1 through heat exchanger HX-1 and stored in a 473 l tank. A pump recirculates domestic hot water through the building. The tank temperature setpoint is 60°C.

Two large decommissioned hot water tanks have been left in the boiler room.

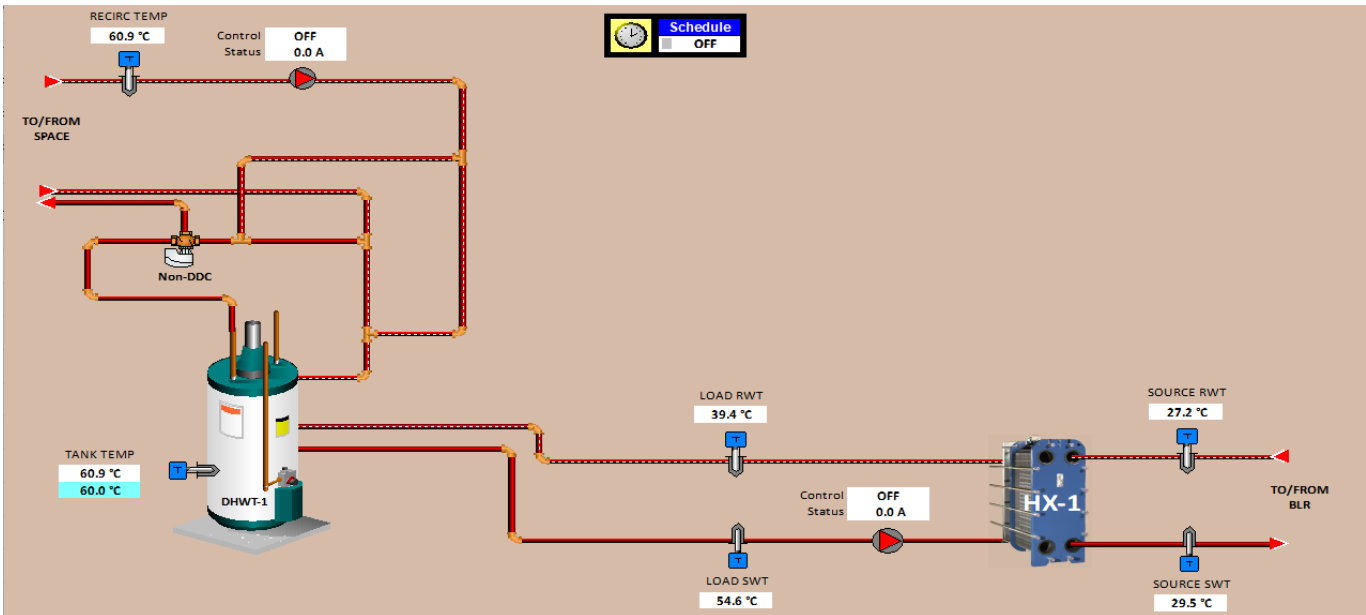

Figure 4: Domestic hot water system

### 4.6 Controls System

The HVAC system is controlled by a Delta Controls DDC, using ORCAView 3.40 software. Remote access to the system is available. Trends are not available from the DDC graphics screens.

An IBC boiler controller provides stages the boilers to meet the secondary loop heating water supply temperature setpoint and domestic hot water setpoint.

## 5.0 Measures Selected for Implementation (Under C.Op. Program)

This section provides an overview of each measure, recommendations for implementation, and update after implementation.

For each measure, costs, savings and payback calculations can be referenced in the *Investigation Summary Table* (see Appendix A).

### 5.1 Measure 1: AHUs running overnight

#### 5.1.1 Description of Finding

Several air handlers run for long periods overnight, while attempting to maintain night setback temperatures.

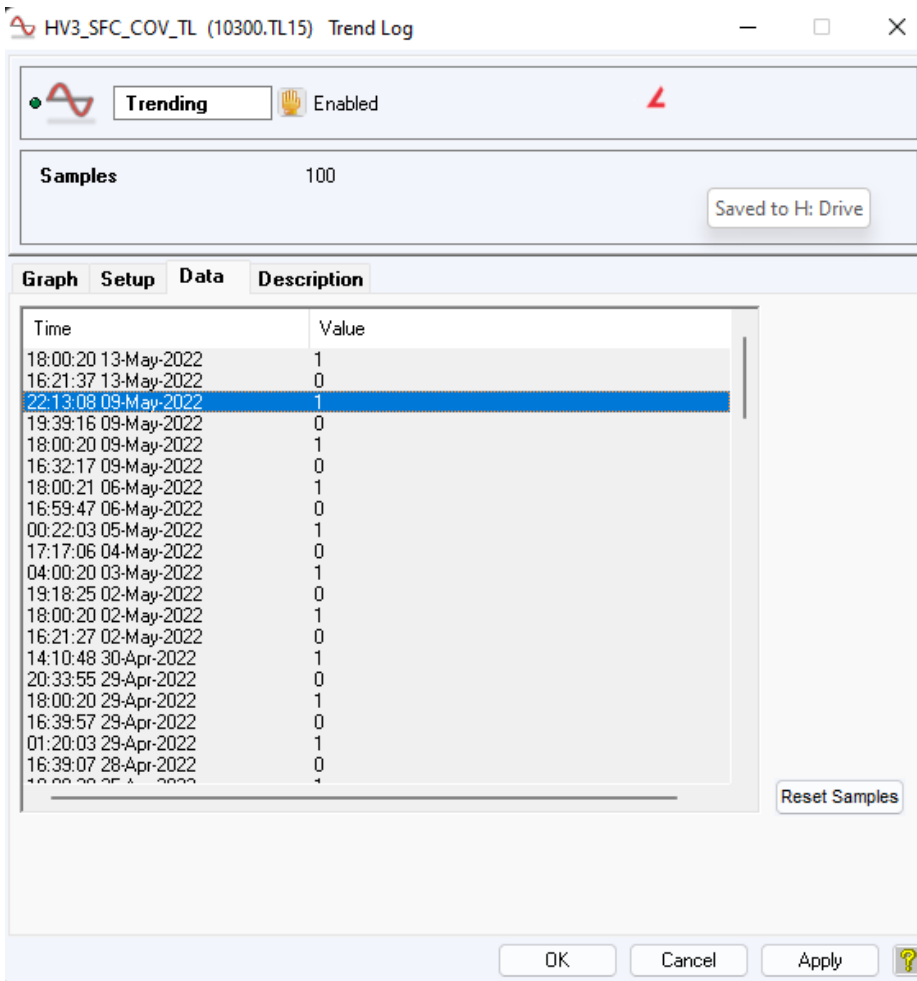

Figure 5: HV-3 supply fan operates almost continuously, running from 9 May to 13 May, then starting soon after.

```

24 HV3_MADCO = MIN (HV3_MADCO, HV3_MAI_BB_CO)
25
26 // [***CONTROL SEQUENCE***]
27 If HV3_FZ Off Then
28   If (HV3_MODE > 1) Or (Enhanced_Air_SCH_BV = On) Then
29     HV3_SFC = On
30   Else
31     HV3_SFC = Switch ( HV3_SFC, HV3_LO_VAR, - 1, 0)
32   End If
33   If HV3_SFS > 2 Then
34 // [***NORMAL OPERATION***]
35     HV3 RFC = On

```

10300.AV5 = -1.94383 °C

**Figure 6: HV-3 switches on when any room it serves drops below the night setback temperature.**

The boilers are disabled when the school is unoccupied, so the AHUs are unable to increase room temperatures, even with heating coil valves fully open.

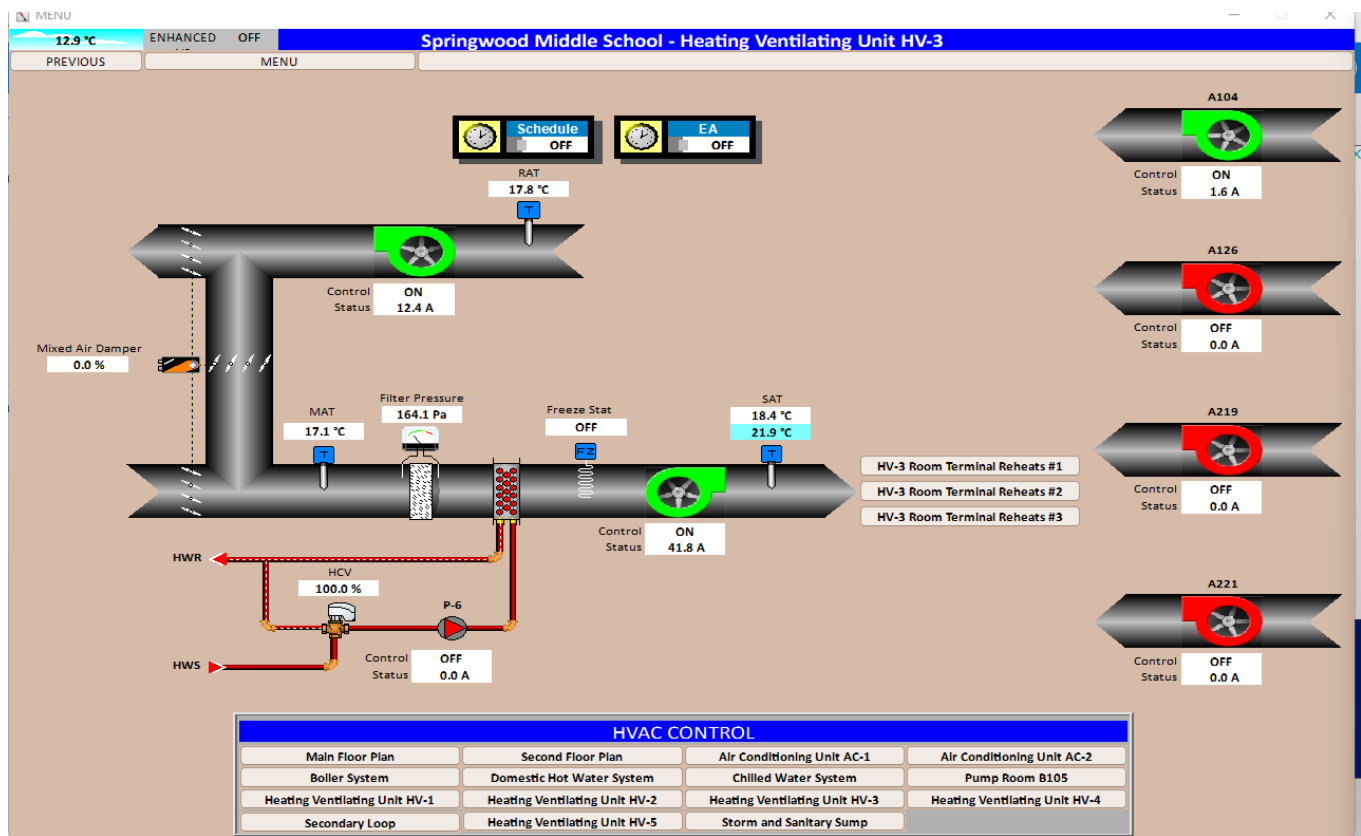

**Figure 7: HV-3 night setback operation: heating coil 100% open but no heat available from boilers, so the supply air only increases slightly (due to heat from the fan).**

The night setback setpoint has been manually overridden to 19C, which makes it more likely that the air handlers need to run.

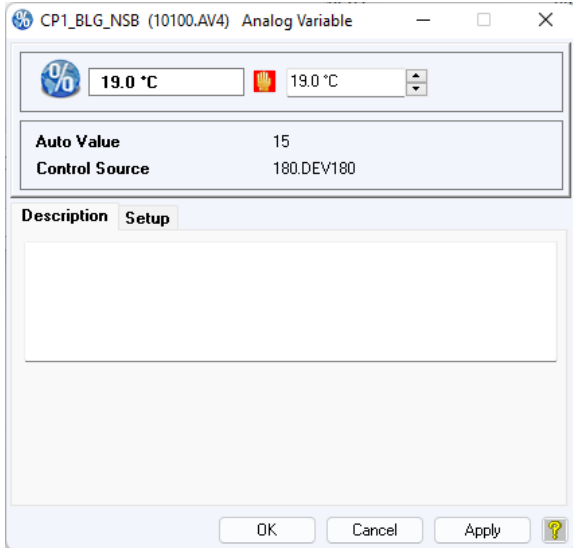

Figure 8: The main building night setback temp is 19°C. It is overridden from a default “Auto Value” of 15°C

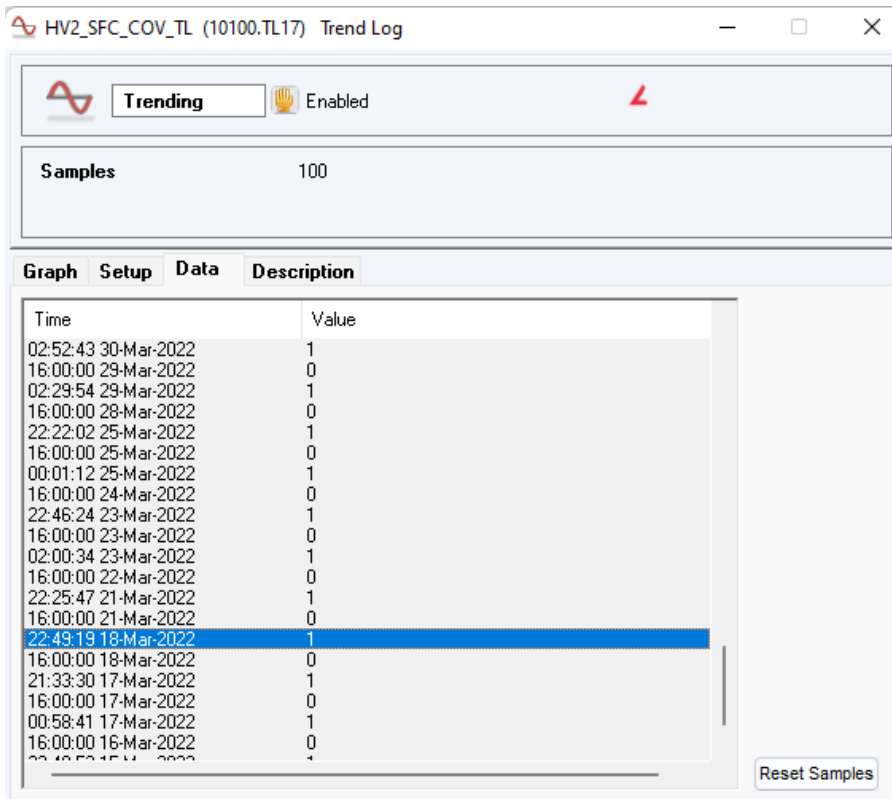

Figure 9: HV-2 supply fan stays on over weekends (18-21 and 25-28 March)



```

..
48 // [***CONTROL SEQUENCE***]
49
50 ● If HV2_FZ Off Then
51 ●   If (HV2_MODE > 1) Or (Enhanced_Air_SCH_BV = On) Then
52 ●     HV2_SFC = On
53 ●     HV2_SF_VSD = HV2_SPEED
54 ●   Else
55 ●     HV2_SFC = Switch ( HV2_SFC, HV2_LO_VAR, - 1, 0)
56 ●     HV2_SF_VSD = 40 * HV2_SFC
57 ●   End If
    
```

10100.AV12 = -1.88178 °C

Figure 10: Similar logic for HV-2

```

21 ● If HV1_FZ Off Then
22 ●   If (HV1_MODE > 1) Or (Enhanced_Air_SCH_BV = On) Then
23 ●     HV1_SFC = On
24 ●   Else
25 ●     // HV1_SFC = Switch ( HV1_SFC, HV1_LO_VAR, - 1, 0) //
26 ●     HV1_SFC = Switch ( HV1_SFC, 10101.B102_RT, 16, 17) //GERRY TEST JAN 2019//
27 ●   End If
    
```

Figure 11: Similar logic for HV-1, but using a lower night setback setpoint (16°C)

The boiler plant is disabled whenever the building is unoccupied, regardless of outdoor air temperature.

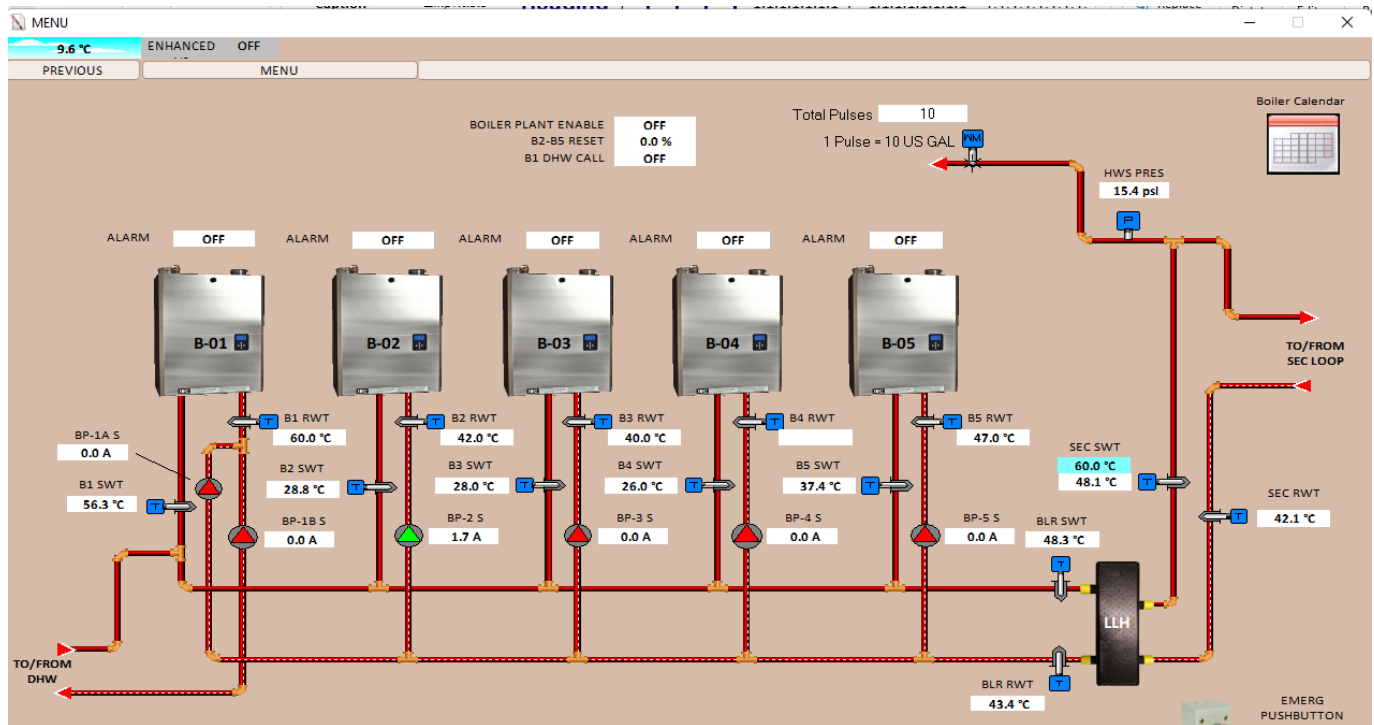

Figure 12: Boilers are disabled during unoccupied hours even when outdoor air is below the 12°C lockout

The boiler program sets the BLR\_UNOCC\_OAT\_ENABLE\_BV variable to "ON" when outdoor temperature is below 12°C, but this value is not used in the program.



```

27 ● BLR_UNOCC_OAT_ENABLE_BV = Off
28 ● Else // - UNOCCUPIED
29 ● BLR_UNOCC_OAT_ENABLE_BV = Switch ( BLR_UNOCC_OAT_ENABLE_BV, OAT_AV, 12, 14)
30 ● BLR_OAT_EN 10000.BV4 = ON Off
31 ● End If
32 ●
    
```

Figure 13: Boilers are supposed to enable at 12°C when unoccupied.

```

32 ●
33 ● //ENABLE/DISABLE BOILERS BASED ON DDC CALENDAR
34 ● BLR_CAL_DISABLE_BV = BOILER_SHUTDOWN
35 ● //GENERAL ENABLE BASED ON DDC CALENDAR AND OAT
36 ● BLR_ENABLE = BLR_OAT_ENABLE_BV * (BLR_CAL_DISABLE_BV = Off)
37 ● 10000.BV1 = OFF
    
```

Figure 14: The BLR\_UNOCC\_OAT\_ENABLE\_BV variable is not referenced in the logic that enables the boilers.

### 5.1.2 Measure Description

Reduce the unoccupied setpoint to 15°C. Enable boilers below 12°C outdoor temperatures (this can be reduced after observing how the HVAC system operates during cold periods).

### 5.1.3 Measure Implementation Update

[Provide confirmation details **AFTER** the measure is implemented and verified]

## 5.2 Measure 2: AHU schedules

### 5.2.1 Description of Finding

Air handlers AC-2, HV-1, HV-2, HV-3, and HV-4 follow the BLDG\_SCHED1 schedule and are scheduled to start three hours earlier on Mondays through Wednesdays than Thursdays and Fridays.

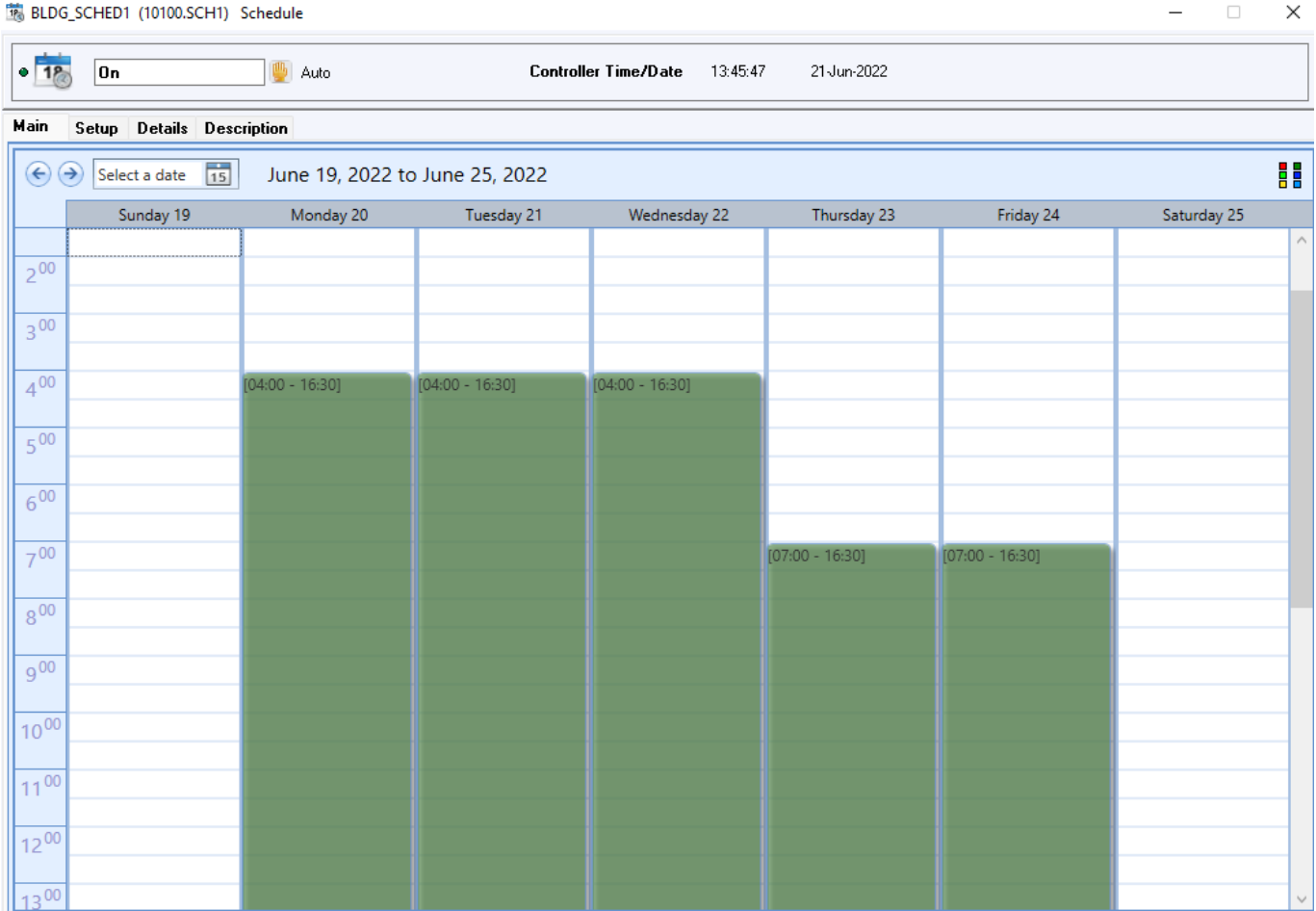

Figure 15: BLDG\_SCHED1 schedule

### 5.2.2 Measure Description

Set morning startup time to 7am for air handlers AC-2, HV-1, HV-2, HV-3, and HV-4 on all school days.

A longer warmup period may be required on Monday mornings, since the building has had time to cool over the whole weekend. Monitor room temperatures on Monday morning, and adjust the start time as required.

### 5.2.3 Measure Implementation Update

[Provide confirmation details **AFTER** the measure is implemented and verified]

## 5.3 Measure 3: Summer schedules

### 5.3.1 Measure Description

There are no summer break schedules set up for summer 2022 in the DDC. The last summer break events were set up were in 2020.

While equipment may be shut off manually during the break, it is more reliable to schedule this in the DDC.

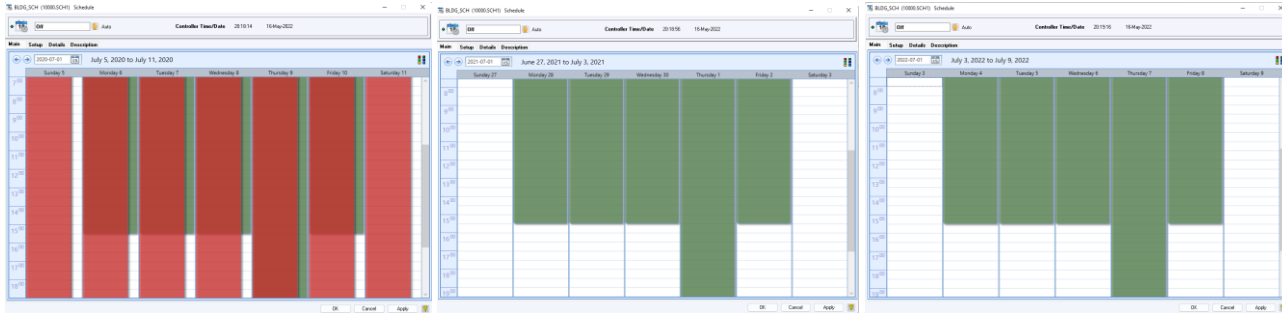

Figure 16: HVAC schedule BLDG\_SCH for July 2020, 2021, and 2022

### 5.3.2 Measure Description

Define a summer break weekly schedule (for example a short morning flush). Add calendar exceptions for the summer break period (July and August). Savings calculations assume normal school week operation is replaced with a 2 hour flush on each weekday.

### 5.3.3 Measure Implementation Update

## 5.4 Measure 4: Boiler temperature overridden to 60°C

### 5.4.1 Description of Finding

The heating water supply temperature setpoint is overridden to 60°C. The DDC programming often calculates the optimal heating water supply temperature setpoint at 40°C. Lowering the heating water temperature reduces gas use through increased boiler condensing efficiency and lower distribution losses.

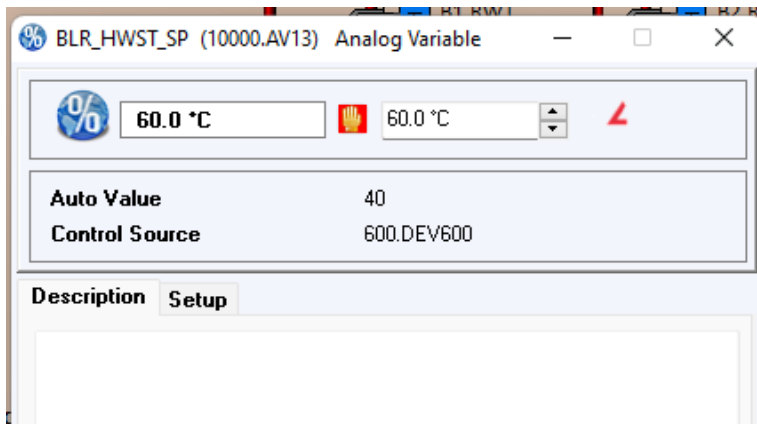

Figure 17: Heating water setpoint manually set to 60°C but the logic calculates setpoint to 40°C. The outdoor temperature was 14.4°C at this time.

### 5.4.2 Measure Description

The supply water temperature during the recent 2021/22 heating season should be confirmed. If the system heated the building successfully with 60°C supply water, this is recommended as the new maximum supply temperature (rather than the current 77°C).

The temperature setpoint should be allowed to drop lower when outdoor temperature and heating load permits it. This may require tuning the programming that optimizes the setpoint.

### 5.4.3 Measure Implementation Update

[Provide confirmation details **AFTER** the measure is implemented and verified]

## 5.5 Measure 5: AC-2 valve and damper control

### 5.5.1 Description of Finding

Figure 18 shows AC-2 modulating its cooling coil valve prior to fully opening its outdoor air damper. At the outdoor air temperature of 15.9°C (as in Figure 18), air handlers should first maximize free cooling before using the chiller.

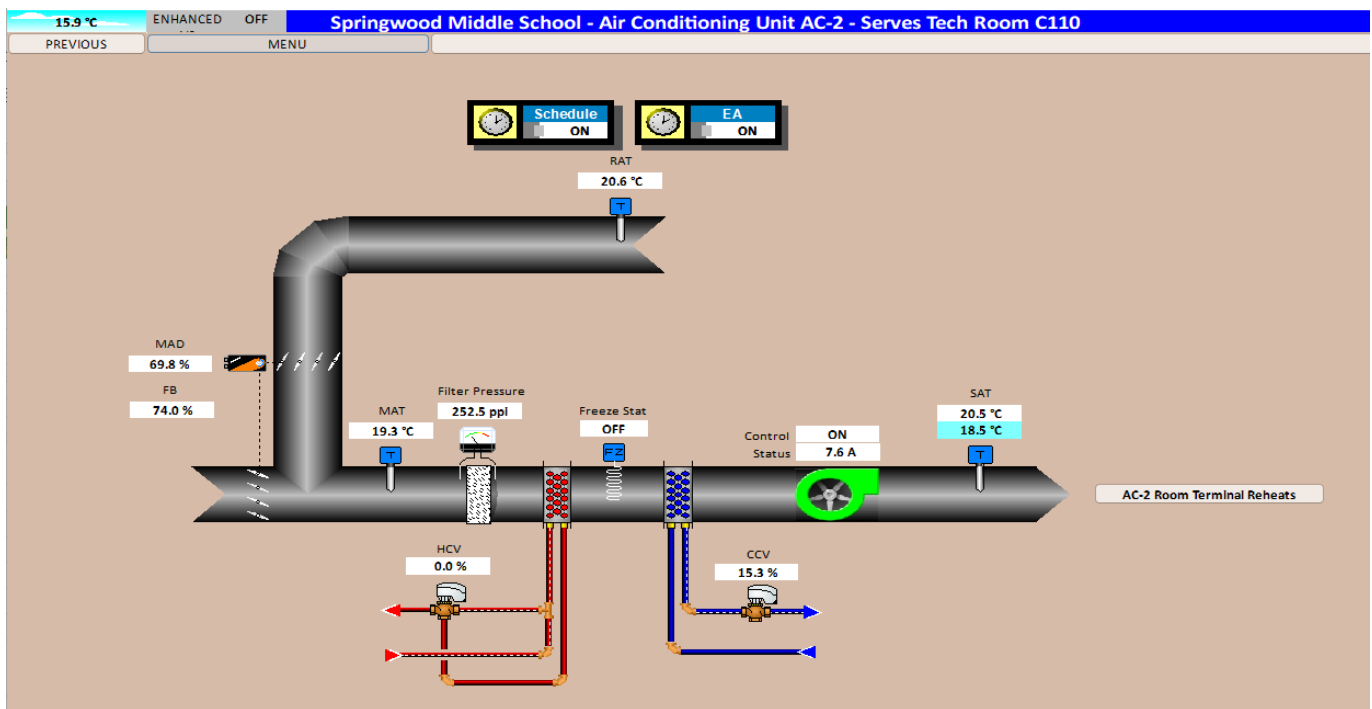

**Figure 18: AC-2 using active cooling before the outdoor dampers are fully open**

The damper, heating valve, and cooling valve are controlled by separate control loops, which leads to unintended overlap in their operation.

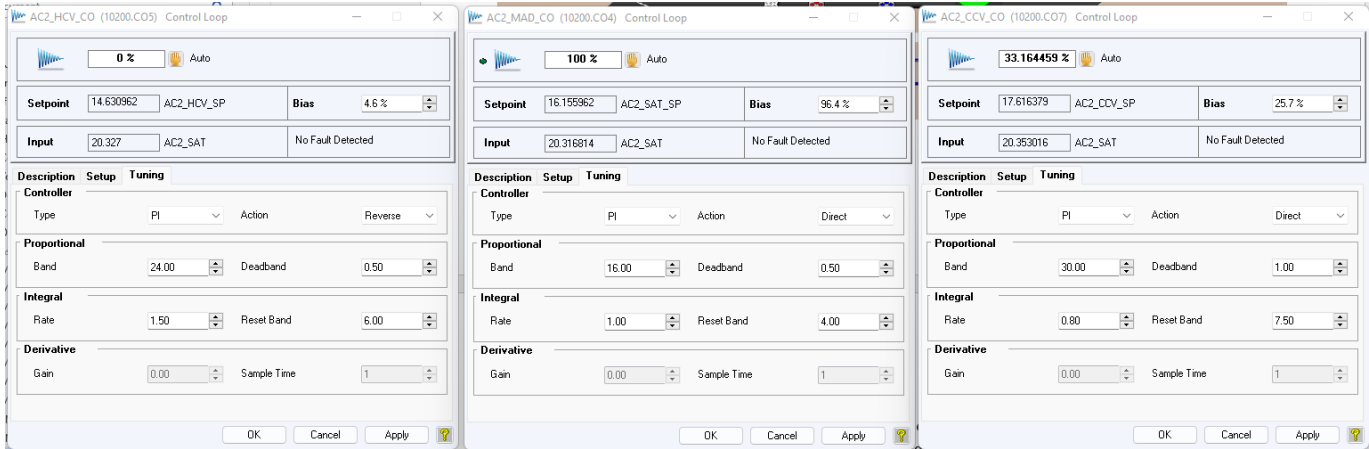

Figure 19: Dampers and valves controlled by three different control loops

### 5.5.2 Measure Description

We recommend that the heating coil, mixing dampers and cooling coil be controlled by a single supply air temperature control loop. The control loop output range would be split into three mutually exclusive full range outputs; one for each operator. This arrangement ensures that all operators are modulated to attain a single temperature setpoint and operator overlap cannot exist.

### 5.5.3 Measure Implementation Update

[Provide confirmation details **AFTER** the measure is implemented and verified]

## 5.6 Measure 6: Ineffective Reheat Coils

### 5.6.1 Description of Finding

The reheat coils listed Table 5 provide negligible heating despite their 100% open reheat coil control valves. The room temperature setpoints for those reheats are typically not being met per Figure 20, Figure 21, and Figure 22, which confirms there is a lack of heating rather than a failed sensor. Failed reheat coils will leave some zones too cold. This may cause the DDC or operators to raise the heating water temperature to compensate, reducing heating efficiency and making it impossible to electrify the building with an air source heat pump.

Table 5: Ineffective reheat coils

Air handler	Ineffective Reheat Coils
AC-1	A131, A137
AC-2	A203
HV-1	B101, B102, B103, B104, B107, B114, CM06, CM03W
HV-3	A103, A105, A113, A117, CM02W, A208, A217

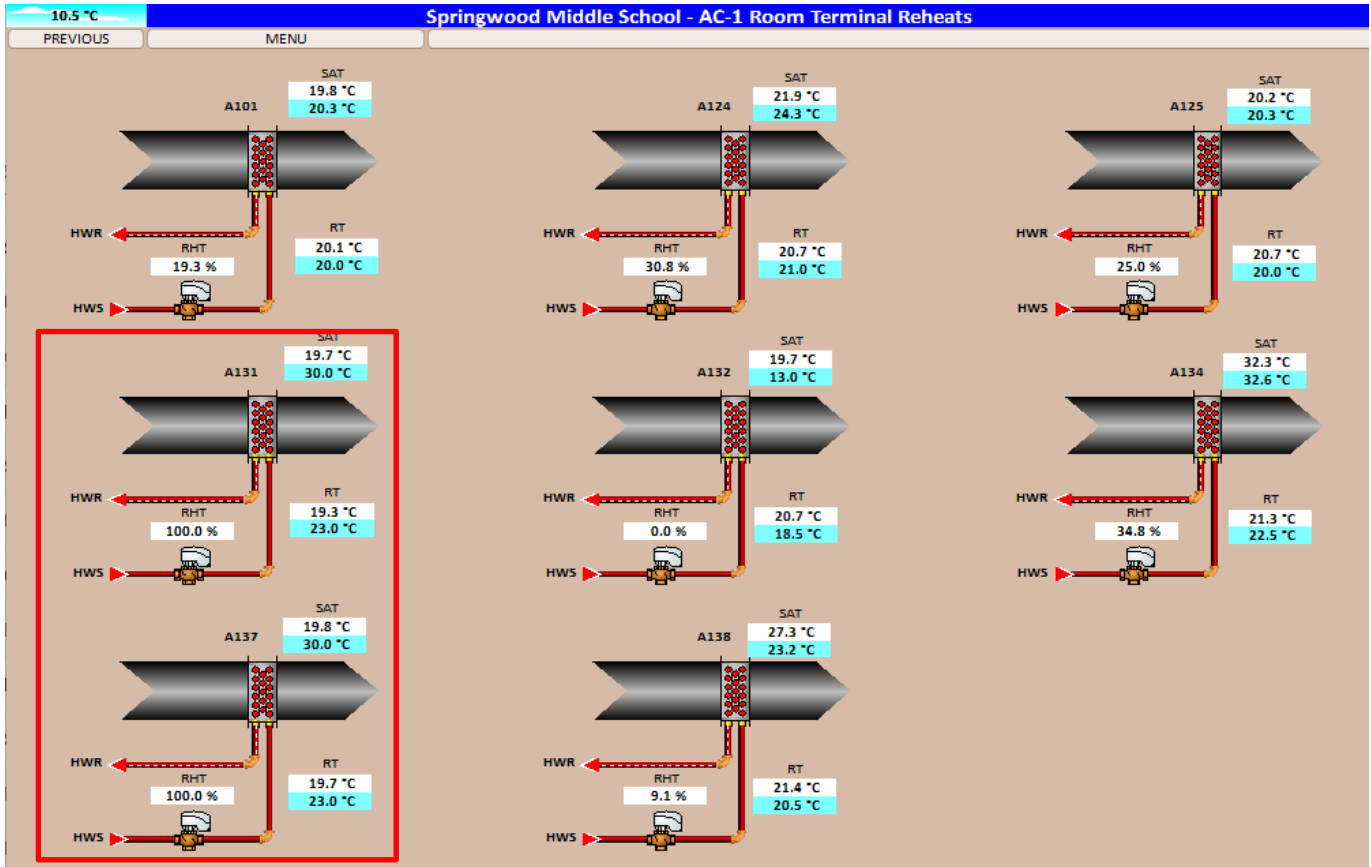

Figure 20: AC-1 failed reheat coils (in red box; low supply air temperature despite 100% open control valve)

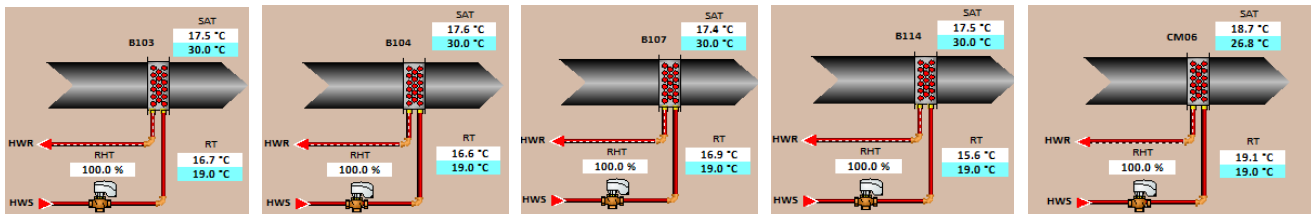

Figure 21: HV-1 failed reheat coils (low supply air temperature despite 100% open control valve)

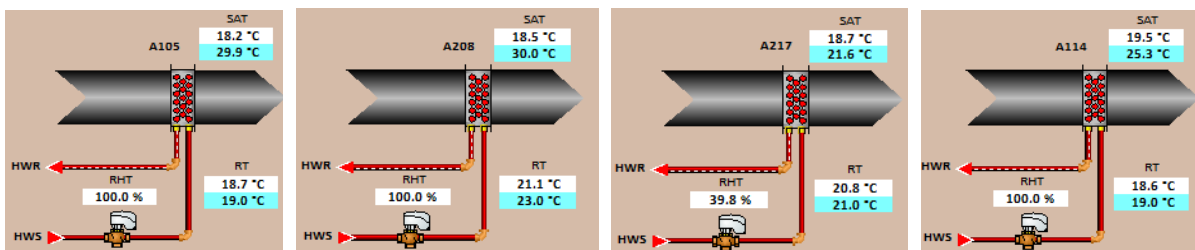

Figure 22: HV-3 failed reheat coils (low supply air temperature despite 100% open control valve)

### 5.6.2 Measure Description

We recommend inspecting each problematic reheat coil and its control valve. Possible causes include closed isolation valves, improper balancing valve positions, air locks, sticking control valve, and dirty coil. Measure costs assume half of the identified control valves needs to be replaced.

### 5.6.3 Measure Implementation Update

[Provide confirmation details **AFTER** the measure is implemented and verified]

## 5.7 Measure 7: HV-5 Broken SAT sensor

### 5.7.1 Description of Finding

The HV-5 supply air temperature sensor (Figure) and the boiler room temperature sensor both report -40°C. They are likely either missing or disconnected. This is causing the HV-5 mixed air damper to remain fully closed at all times and for HV-5 to provide no outdoor air to its zones.

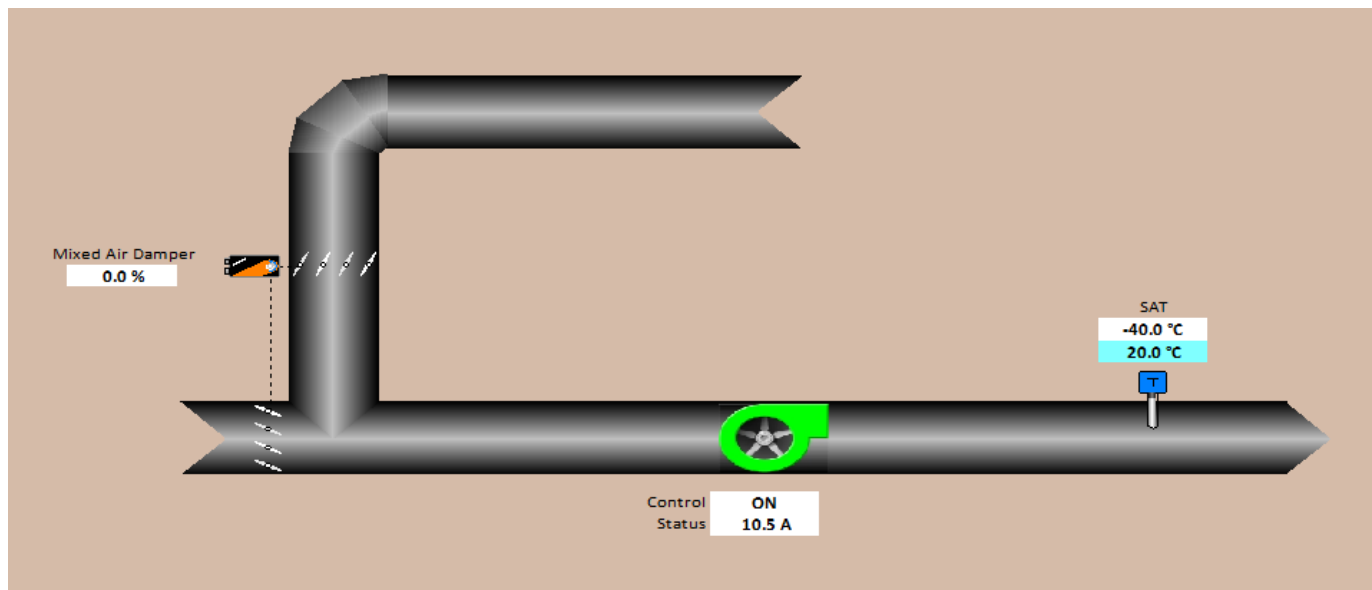

### 5.7.2 Measure Description

Reconnect or replace both sensors.

### 5.7.3 Measure Implementation Update

[Provide confirmation details **AFTER** the measure is implemented and verified]

## 5.8 Measure 8: HV-2 RF not running when SF is at 40%

### 5.8.1 Description of Finding

HV-2 is programmed to only operate its return fan if the supply fan speed feedback exceeds 40% per Figure 23. When the supply fan speed is set to 40% (typical during unoccupied periods), the speed feedback is below 40% so the return fan is off. Note that the DDC graphic in Figure 24 is incorrect: the return fan shows the state of the supply fan, and vice versa.



```

--
50 ● If HV2_FZ Off Then
51 ●   If (HV2_MODE > 1) Or (Enhanced_Air_SCH_BV = On) Then
52 ●     HV2_SFC = On
53 ●     HV2_SF_VSD = HV2_SPEED
54 ●   Else
55 ●     HV2_SFC = Switch ( HV2_SFC, HV2_LO_VAR, - 1, 0)
56 ●     HV2_SF_VSD = 40 * HV2_SFC
57 ●   End If
58 ●   If HV2_SF|SPD > 40 Then
59 ●     // [***N(10100.AI28 = 39.29129 % DN***)]
60 ●     HV2_RFC = On
61 ●     HV2_RF_VSD = HV2_SPEED
62 ●     //Mad control when enhanced air mode is active.
63 ●

```

Figure 23: HV-2 fan logic

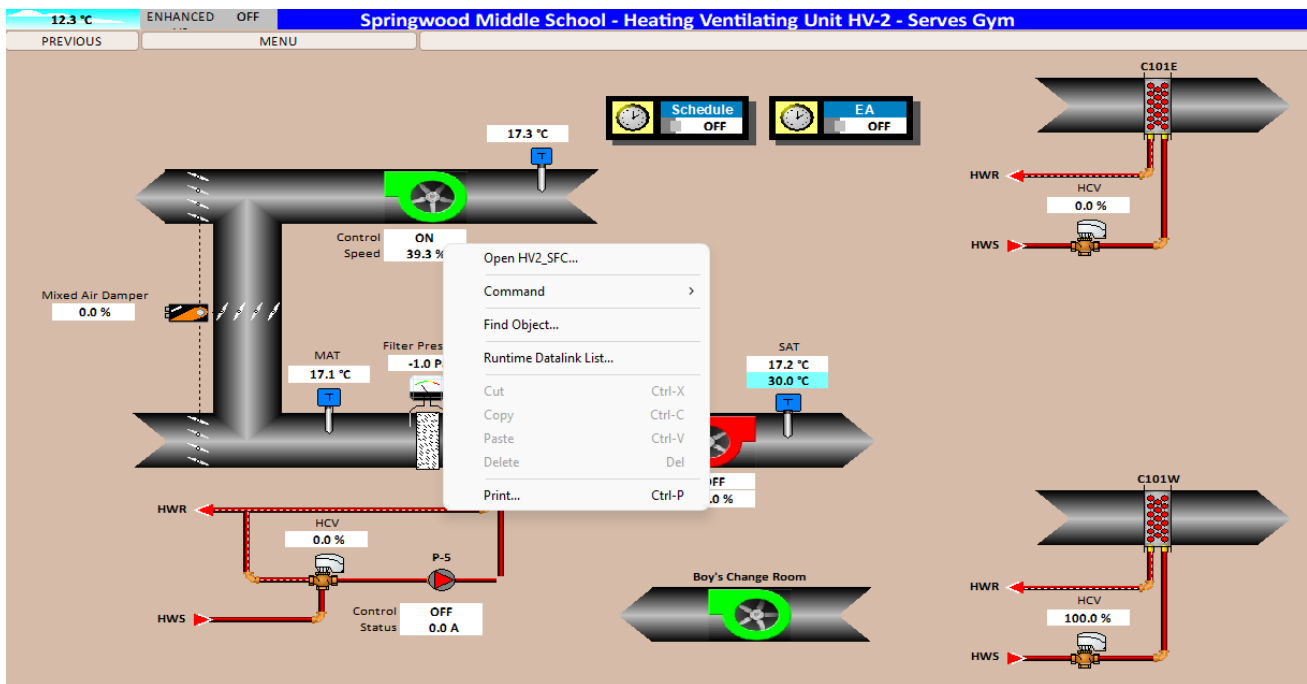

Figure 24: Supply fan and return fan values are swapped in the HV-2 DDC graphics

### 5.8.2 Measure Description

Revise HV-2 programming to account for possible error in the supply fan speed feedback.

### 5.8.3 Measure Implementation Update

[Provide confirmation details **AFTER** the measure is implemented and verified]

## 5.9 Measure 9: AC-1 mixed air temperature is higher than expected

### 5.9.1 Description of Finding

Figure 25 shows AC-1 mixed air temperature only 1.2°C below the return air temperature despite the mixed air damper reporting 36.9% open and an outdoor air temperature of 9.7°C. This situation was common during the investigation phase. It suggests AC-1 is not obtaining the outdoor air it requires per design and will increase chiller electricity use in warmer weather.

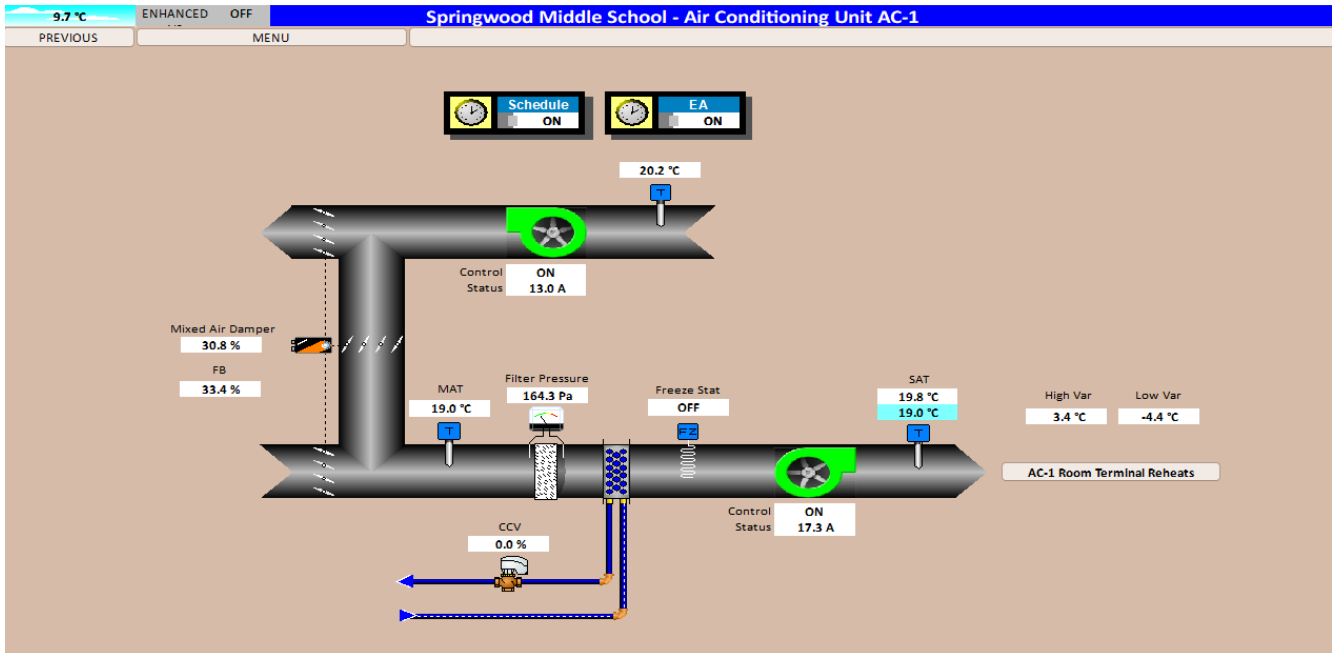

Figure 25: AC-1

### 5.9.2 Measure Description

Inspect the AC-1 dampers and damper actuators, and check if there are air flow obstructions along AC-1's outdoor air intake or exhaust ducts. Test sending various commands to the mixed air damper and visually confirm the damper blades move to the desired positions.

Measure costs assume mechanical cooling is currently required at 16°C outdoor temperature, and additional free cooling from properly operating damper can delay the need for active until outdoor temperatures reach 18°C.

### 5.9.3 Measure Implementation Update

[Provide confirmation details **AFTER** the measure is implemented and verified]

## 6.0 Measures to be considered for Future Implementation

This section provides an overview of each measure (that was identified but **was not selected** as part of this C. Op. project, but maybe considered for future implementation), recommendations for implementation, and the most suitable method for providing evidence of implementation. See Appendix A - Investigation Phase Summary Table for more details.

### 6.1 *Measure 10: Replace chiller with reversible heat pump*

The boiler loop supply temperature is currently set manually to 60°C. The boiler program indicates that the setpoint would typically reset down to 40°C. Commercially available air and ground source heat pumps can efficiently heat water to 50°C. If SD69 is able to repair reheat coils and tune the reset to operate at such a heating water supply temperature setpoint, Springwood Elementary would be a candidate for low carbon electrification by supplementing the existing boilers plant with air or ground source heat pumps.

If the chiller is original to the building (1993), it would be nearing its end-of-service-life. If so, we propose replacing it with a two-pipe reversible air source heat pump. The heat pump would provide chilled water whenever AC-1 or AC-2 require cooling like the existing chiller but provide 1<sup>st</sup>-stage heating at other times. The boilers plant would remain to supplement building heating.

A feasibility study is recommended as the next step to assessing the viability of this project. The boiler plant's heating water supply temperature should be trended through winter to confirm the fraction of the year a heat pump could supplement the heating system. Mechanical and structural assessments are required to refine the cost and viability of the project. Measure costs assume the air source heat pump matches the existing chiller's electrical requirements (avoiding an electrical upgrade), but options for installing a larger unit should be assessed in the study.

## 7.0 Next Steps – Implementation Phase and Completion Phase

### 7.1 Implementation Phase

To continue in the program, the owner is responsible for implementing the selected bundle of measures that pay back in two years or less. Using the *Recommissioning Report* for implementation allows flexibility in how the selected measures are implemented. Options include: utilize in-house building staff, hire the C.Op Provider to implement or provide technical assistance, contract with outside service contractors, or any combination of the above.

### 7.2 Completion Phase

C.Op Service provider will follow up after implementation of the selected measures and **update** this *Recommissioning report and Recommissioning Workbook*.

The updated report for the implemented measures includes but not limited to: date of completion of each measure, new or improved sequences of operation, the energy savings impact of the measures, the requirements for ongoing maintenance and monitoring of the measures, and contact information for the service provider, in house staff, and contractors responsible for the implementation. When feasible, verification data should include trends or functional test results, though other methods, such as copies of invoices, site visit reports, and before/after photos, may be acceptable.

The C.Op Service Provider will conduct an in-house (teleconference) session for the Applicant and the appropriate building operations personnel covering the new documentation, measures that were implemented, and requirements for ongoing maintenance and monitoring. Document the attendance of the building operations staff.

The *updated Recommissioning Workbook* and *updated Recommissioning Report* will be submitted to the owner and the program for review. See Appendix B: Completion Phase Summary Table for more details on implemented measures.

## Appendix A: Investigation Phase Summary Table

Investigation Phase Summary				Investigation Phase							
ECM #	Measure Title	Measure History	Include cost	Energy Savings			Cost Savings	Financial		Est. GHG Reduction	Enter "x" if DESELECT for implementation
				Demand (kW)	Electrical (kWh/yr)	Fuel (GJ)	Total (\$/yr)	Estimated Measure Cost (\$)	Simple Payback (yrs)	tonnes CO2e/yr	
ECM-1	AHUs running overnight	New	1	-	136,444	-	\$ 13,442	\$ 700	0.1	1.5	
ECM-2	AHU Schedules	New	1	-	20,214	129	\$ 3,552	\$ 1,100	0.3	6.6	
ECM-3	Summer schedules	New	1	-	13,487	-	\$ 1,329	\$ 900	0.7	0.1	
ECM-4	Boiler temperature override	New	1	-	-	42	\$ 514	\$ 400	0.8	2.1	
ECM-5	AC-2 valve and damper control	New	1	-	102	-	\$ 10	\$ 900	89.6	0.0	
ECM-6	Ineffective Reheat Coils	New	1	-	-	-	\$ -	\$ 10,600	#DIV/0!	-	
ECM-7	Broken HV-5 SAT sensor	New	1	-	-	-	\$ -	\$ 300	#DIV/0!	-	
ECM-8	HV-2 return fan not running when SF is at 4	New	1	-	-	-	\$ -	\$ 400	#DIV/0!	-	
ECM-9	AC-1 mixed air temperature	New	1	-	203	-	\$ 20	\$ 900	44.9	0.0	
ECM-10	Replace chiller with reversible heat pump	New	1	-	68,431	812	\$ 3,104	\$ 264,900	85.3	39.8	x
TOTAL (Previous, still working):				-	-	-	\$ -	n/a	n/a	-	
TOTAL (All potential measures for Implementation):				-	102,019	983	\$ 21,971	\$ 281,100	12.8	50.1	
TOTAL (Selected measures only):				-	170,450	171	\$ 18,867	\$ 16,200	0.9	10.4	

Implementation cap @\$0.25/ft2 \$ 14,174

## Appendix B: Completion Phase Summary Table

[Paste image of Completion Summary Table from the RCx Workbook **AFTER** Implementation]

## Appendix C: Sample Training Outline

### [Completion Report AFTER Implementation]

The Commissioning Provider (C.Op Provider) may customize the outline for the training and developing the training materials. Before preparing the training outline and materials, the C.Op Provider should assess the related level of knowledge of the building operators, to set up the training accordingly. For reference, the Program provides the following sample outline for the training:

- Background on the energy use of this particular building
  - Present Energy Utilization Index
  - Describe Operating Schedules and Owner's operating requirements
- RCx investigation process used in this building
  - Describe the methods used to identify problems and deficiencies
  - Review the RCx Workbook
- Implementation process in this building
  - Describe the measures that were implemented and by whom
  - Walk around the building to look at any physical changes or step through the new control sequences at the operator workstation
  - Provide as many details about implementation as necessary to describe what was done
  - Describe improved performance that these measures will create (show trends if available)
- O&M requirements
  - Describe the O&M requirements needed to keep these improvements working
  - Describe how the staff can be aware of energy efficiency opportunities and begin looking for additional savings potential

The C.Op Provider should follow the outline to prepare materials, as necessary, to hand out at the training session.



## Appendix D: Training Completion Form

Project ID
------------

### Facility Information

Company Name	Building Name(s)
Facility Address	City Province

### Training Details

Location	Date
Commissioning Provider/Trainer	

### Materials Attached

<input type="checkbox"/> Agenda
<input type="checkbox"/> Materials used for training
<input type="checkbox"/> List of individuals who attended

### COMMISSIONING PROVIDER SIGNATURE

By signing this Training Completion Form, I verify that this training took place with the listed attendees.	
Commissioning Provider (print name):	
Signature:	Date:

**FACSIMILE/SCANNED SIGNATURES:** Facsimile transmission of any signed original document, and the retransmission of any signed facsimile transmission, shall be the same as delivery of the original signed document. Scanned original documents transmitted to BC Hydro as an attachment via electronic mail shall be the same as delivery of the original signed document. At the request of BC Hydro, C.Op Provider shall confirm documents with a facsimile transmitted signature or a scanned signature by providing an original document.



Targeted Documentation

O & M Manual

O & M Manual updated <input type="checkbox"/>	Describe updates below and attach copies of new or amended portions
O & M Manual not updated <input type="checkbox"/>	Province reasons below
Building has no O & M Manual <input type="checkbox"/>	

Building Plans (“as-builts”)

Building Plans updated <input type="checkbox"/>	Describe below
Wiring diagrams updated <input type="checkbox"/>	Describe below
No plans or diagrams updated <input type="checkbox"/>	Describe below

EMS Programming

New sequences of operation on file <input type="checkbox"/>	Specify location of file and attach copy
Printed screenshots on file <input type="checkbox"/>	Specify location of file and attach copy

Equipment Manuals



Manuals for new equipment are on file <input type="checkbox"/>	Describe below (attach copy if applicable)



Checklist of subjects discussed at training

Explain investigation process and how measures were identified	<input type="checkbox"/>
Describe implemented measures, and how they are reducing energy usage	<input type="checkbox"/>
Building walkthrough to show implemented measures	<input type="checkbox"/>
Describe methods for monitoring and maintaining optimum system performance related to implemented measures	<input type="checkbox"/>
Describe scenarios where system setting changes would be required, and how to maintain optimum energy efficiency, e.g., seasonal-based manual adjustments to setpoints.	<input type="checkbox"/>



**List of Individuals Who Attended**

<b>Name</b>	<b>Title</b>	<b>Building (address or name)</b>	<b>Contact information (e-mail and/or phone number)</b>

Continuous Optimization for Commercial Buildings Program

# Recommissioning Report

---

Version	Updated on	Phase
1	July 17, 2022	Investigation phase. Draft for client review.

Prepared for:

School District 69

Ballenas Secondary School

135 Pym St

Parksville, BC

Project: BCH-07832

Prism Project: 2021300

---

Prepared by:

Prism Engineering Ltd.

#320 - 3605 Gilmore Way

Burnaby, BC



# TABLE OF CONTENTS

<b>1.0</b>	<b>INTRODUCTION</b> .....	<b>3</b>
<b>2.0</b>	<b>PROJECT OVERVIEW</b> .....	<b>4</b>
<b>3.0</b>	<b>SAVINGS SUMMARY</b> .....	<b>5</b>
<b>4.0</b>	<b>BRIEF DESCRIPTION OF EXISTING SYSTEM</b> .....	<b>6</b>
4.1	FACILITY DESCRIPTION.....	6
4.2	HEATING SYSTEM.....	6
4.3	COOLING SYSTEM.....	9
4.4	VENTILATION SYSTEM.....	10
4.5	DOMESTIC HOT WATER SYSTEM.....	12
4.6	CONTROLS SYSTEM.....	12
<b>5.0</b>	<b>MEASURES SELECTED FOR IMPLEMENTATION (UNDER C.OP. PROGRAM)</b> .....	<b>14</b>
5.1	MEASURE 1: REHEAT COILS.....	14
5.2	MEASURE 2: FAN FEEDBACK SENSOR.....	16
5.3	MEASURE 3: MORNING SCHEDULES.....	18
5.4	MEASURE 4: NIGHT SETBACK TEMPERATURES.....	19
5.5	MEASURE 5: HOLIDAY SCHEDULE.....	20
5.6	MEASURE 6: EXHAUST FANS RUN OUTSIDE OCCUPIED PERIODS.....	21
5.7	MEASURE 7: HV5 TEMPS AND HEATING COILS.....	22
5.8	MEASURE 8: TEMPERATURE SENSORS.....	23
<b>6.0</b>	<b>MEASURES TO BE CONSIDERED FOR FUTURE IMPLEMENTATION</b> .....	<b>26</b>
6.1	MEASURE 9: REVERSIBLE HEAT PUMPS FOR EXISTING DX COILS.....	26
6.2	MEASURE 10: HYDRONIC AIR SOURCE HEAT PUMP.....	30
<b>7.0</b>	<b>NEXT STEPS – IMPLEMENTATION PHASE AND COMPLETION PHASE</b> .....	<b>30</b>
7.1	IMPLEMENTATION PHASE.....	30
7.2	COMPLETION PHASE.....	30
<b>APPENDIX A:</b>	<b> INVESTIGATION PHASE SUMMARY TABLE</b> .....	<b>32</b>
<b>APPENDIX B:</b>	<b> COMPLETION PHASE SUMMARY TABLE</b> .....	<b>33</b>
<b>APPENDIX C:</b>	<b> SAMPLE TRAINING OUTLINE</b> .....	<b>34</b>
<b>APPENDIX D:</b>	<b> TRAINING COMPLETION FORM</b> .....	<b>35</b>
<b>APPENDIX E:</b>	<b> REHEAT COILS</b> .....	<b>39</b>

## 1.0 Introduction

Prism Engineering is pleased to present the results of the Investigation Phase that was conducted as part of BC Hydro's Continuous Optimization for Commercial Buildings Program for Ballenas Secondary School. The objective of an Investigation is to identify deficiencies and improvements in the operation of a facility's mechanical equipment, lighting, and related controls, and determine opportunities for corrective action that reduce energy consumption and preserve the indoor environmental quality.

This document is a complete record of the work performed at this facility, including the in-depth investigation of the building systems and the implementation of selected measures to optimize building performance.

The Recommissioning Investigation Report provides an overview of the recommendations for the implementation of measures. This information is not considered a specification or detailed sequence of operations. The intent is to provide an overview of the recommendation that can be built upon during the implementation phase as part of any detailed design that may be required. Certain measures may require further investigation and specification for the correct implementation by the owner or the DDC contractor.

Eight recommended retrofits were identified as a part of this investigation. The proposed measures will be reviewed in a meeting with School District 69 and Prism Engineering representatives to determine which measures will be implemented.

Recommended retrofits for implementation include:

- Measure 1: Reheat coils
- Measure 2: Fan feedback sensors
- Measure 3: Morning schedule
- Measure 4: Night setback temperatures
- Measure 5: Holiday schedules
- Measure 6: Exhaust fans run outside occupied hours
- Measure 7: HV5 temps and heating coils
- Measure 8: Temperature sensors

These measures are presented in the Investigation Summary Table (see Appendix A).

While the investigation focuses on low-cost improvements with short paybacks, some capital improvement opportunities may also be identified. Major retrofit measures are beyond the scope of this program, but other BC Hydro and FortisBC programs provide a variety of incentives to complete the retrofits. Retrofits were identified as a part of this investigation that could potentially qualify for other BC Hydro and FortisBC programs, these measures are described in Section 6.

Retrofits include:

- Measure 9: Reversible heat pumps for existing DX coils
- Measure 10: Hydronic Air Source Heat Pump



## 2.0 Project Overview

Project Information		Complete cells this background colour			
RCx Project File #	BCH-07832				
Date of Workbook Update	20-Jun-2022				
Organization	School District 69				
Building Name	Ballenas Secondary School				
Building Type	Large School				
Location (City)	Parksville, BC				
Owner Contact	Phil Munro				
Investigation Phase start date	01-Feb-2022				
Participated in previous BCH RCx program?	No				
Previous RCx File #					
Previous RCx completion date					
<b>Building Information</b>					
Facility Area (ft <sup>2</sup> )	117,143				
Annual elec consumption (kWh)	588,484	5.0		kWh/ft <sup>2</sup>	
Annual elec costs (\$)	\$ 58,056	\$ 0.10		Avg. \$/kWh	
Fuel type	Natural Gas				
Annual fuel consumption (GJ)	3,919	9.3		ekWh/ft <sup>2</sup>	
Annual fuel cost (\$)	\$ 47,505	\$ 12.1		Avg. \$/GJ	
Total GHG emissions (tCO <sub>2</sub> e/yr)	202				
Total Energy Cost	\$ 105,560	\$ 0.90		\$/ft <sup>2</sup>	
Energy Use Intensity (ekWh/ft <sup>2</sup> )	14.3				
Year for energy data above	2020				





### 3.0 Savings Summary

[Paste image of Savings Summary Table from the RCx Workbook – also **UPDATE after** Implementation]

Savings Summary	Previous, still working	New + Previous, rectify + Previous, documented					
		Identified		Selected		Implemented	
	# of measures	9		8		8	
	Re-claim Savings	Total Savings	% Savings	Total Savings	% Savings	Total Savings	% Savings
Electrical savings (kWh/yr)	-	80,837	-13.7%	47,454	8.1%	47,454	8.1%
Fuel savings (GJ/yr)	-	2,629	67.1%	1,090	27.8%	1,090	27.8%
Cost savings (\$)	\$ -	\$ 23,893	22.6%	\$ 17,888	16.9%	\$ 17,888	16.9%
GHG reduction (tCO2e/yr)	-	130.2	64.6%	54.8	27.2%	54.8	27.2%
<b># of Abandoned measures</b>	<b>0</b>						



## 4.0 Brief Description of Existing System

This section contains a brief description of the existing HVAC and Controls system. The information is intended to provide a general overview only.

### 4.1 Facility Description

Ballenas Secondary School was built in 1976 with several later additions. The current floor area is 117,143 sqft. The building includes classrooms, administration offices, gym, theater, art studio, and technical teaching areas.

**Table 1: Schedules**

	Area	Days	From	To
Occupancy	Classrooms	All schooldays	8:40am	3:05pm
	Office hours	All school days	7:30am	4pm
Building Equipment	4.WS1	Monday-Friday	7am	4pm
		June/July	7am 1pm	9am 3pm
	Main schedule	Monday-Friday	7am	4pm (3:45pm Thu)
		Holidays	Off	

### 4.2 Heating System

Heating for the building is provided by three boilers, see Table 2.

**Table 2: Boilers**

Boiler	Area
B-1	Veissmann Vitocrossal 200 condensing boilers
B-2	1071 MBH (input)
B-3	Veissmann Vitorond 200 non-condensing 1096 MBH (input)



Figure 1: Boilers B-2 (left) and B-3. B-1 is the same make and model as B-2.

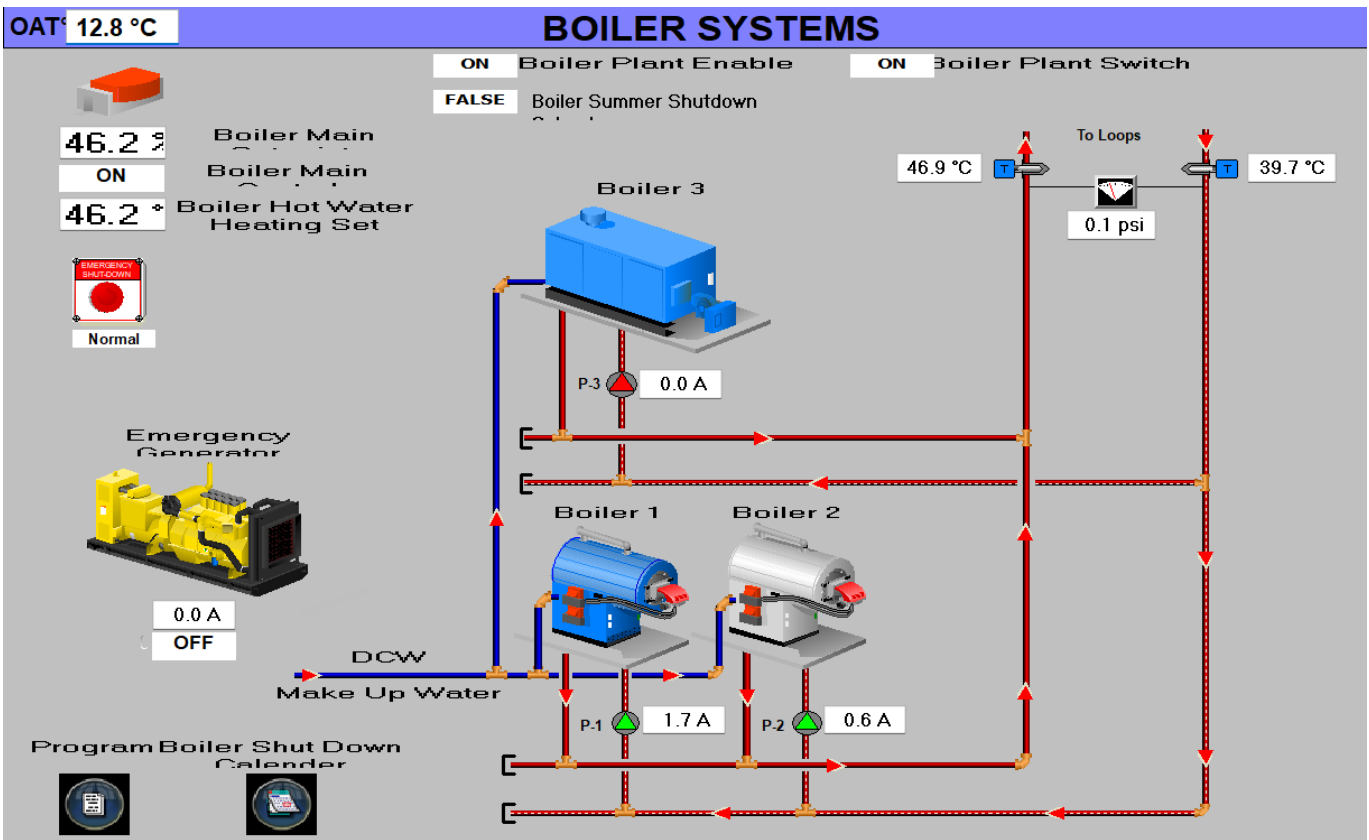

Figure 2: Boilers DDC Graphic



Heating water is distributed through six loops to air handlers, duct mounted reheat coils, fan coils, unit heaters, and radiant panels.

**Table 3: Pumps**

Tag	Serves	Size	Flow	Head (Ft)
P-1 P-2	Boiler pumps for B-1 and B-2			
P-3	Boiler pump for B-3	305W		
P-4	Woodshop	440W		
P-5	900 Wing	990W		
P-6	“main Loop”	1150W		
P-7	600 Wing	380W		
P-8	300 Wing	430W		
P-9	400 Wing	430W		
P-HV3	HV3 HC	1/6 HP	0.63 l/s	48 KPa
P-AHU3	AHU3 HC	144 W (estimate)		
P-AHU4	AHU4 HC	740 W (estimate)		
P-HV5	HV5 HC	500W	2.5 l/s	28 ft
P-HV8-P2	HV8AC8 loop	1/2 HP	2.27 l/s	51 kPa
P-HV8-P1	HV8AC8 HC	1/3 HP	1.5 l/s	60 kPa
P-HV13-PS	HV13 HC	1/12 HP	0.5 l/s	15 ft
P-HV14-PS	HV14 HC	1/12 HP	0.5 l/s	15 ft
P-DHWR	DHW Circulation	Unknown		

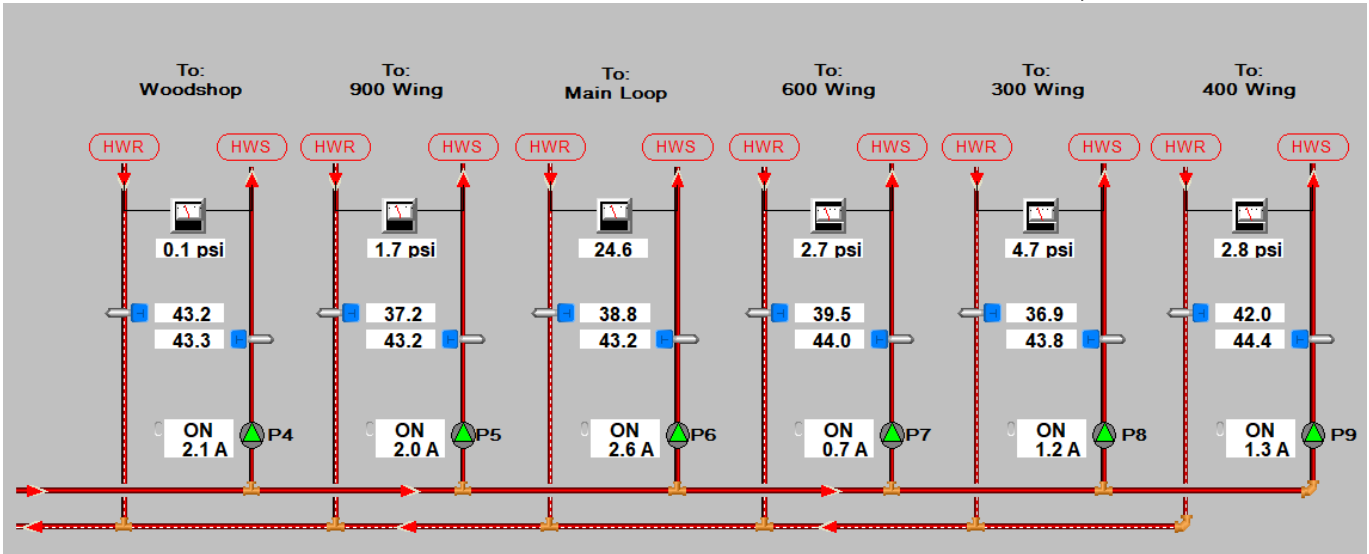

Figure 3: Main distribution loops

A glycol heating loop serves the heating coil in HV5; this is heated by heat exchanger HX-HV5, see Figure 4.



Figure 4: HX-HV5 heat exchanger

### 4.3 Cooling System

There is no central cooling system, but several air handlers have DX cooling, detailed in section 4.4, and there are smaller mini split units serving specific spaces, see **Error! Reference source not found.** for example.



Figure 5: Additional Fujitsu split unit above multi-use area.

### 4.4 Ventilation System

The building has 18 air handlers, see Table 4. Most are installed on the roof.

Table 4: Air Handling Units

Tag	Service	Airflow (cfm)	Supply Fan (HP)	Return Fan (HP)	Heating/cooling coils	Outdoor air	Schedule
HV1A	Multi-use space	21,405	15	7.5	Heating coil	Mix 30% Min	Matches 4.WS1 0% OA
HV2	Office and 200 Wing via reheats	9,464	7.5	3	DX cooling, 23 Ton	Mix 30% Min	1.WS1
HV2A	900 Wing	9,345	7.5	5	In-duct DX coils Heating coil	Mix 30% Min	1.WS1
AHU3	300 Wing	5,500	5 VSD	-	Heating coil	Mix 30% Min	1.WS1
HV3	Science	6,140	5	1.5	Heating coil.	Mix 30% Min	1.WS1
HV3A	900 West	11,260	7.5	5	In-duct DX coils Heating coil	Mix 30% Min	1.WS1
AHU4	Library 602 605	7,000	5 VSD	3 VSD	Heating coil.	Mix 30% Min	1.WS1
HV4	700 Block Art studio	2,000	1	-	DX cooling, 6 1/4 Ton Heating coil. Electric heat.	Mix 30% Min	1.WS1
AHU5	Shop Area	2,500	2 VSD	-	Heating coil	Mix 30% Min	

Tag	Service	Airflow (cfm)	Supply Fan (HP)	Return Fan (HP)	Heating/cooling coils	Outdoor air	Schedule
HV5	Wood Shop	9,000	7.5		Heating coil	Mix Min 10%	50200.SCH1 5am-4:30pm M-F
HV8AC8	400 Wing	10,299	7.5	5	DX cooling 2-stage, 28 Ton Heating coil	Mix Min 30%.	6am-4pm M-F 7am start Wed
HV9 (MUA)	Tech Lab	6000	3	-	None	100% OA	1.WS1
HV10	Auditorium	6,362	5	-	3 heating coils (one for each zone)	Mix 30% Min	6.WS6 8am-4pm M-F
HV11	Gym	10,600 (est.)	7.5	-	Heating coil	Mix 30% Min	6.WS6 8am-4pm M-F
HV11A	Weights / Gym Mezz	2400 cfm	1.5	-	DX cooling 2-stage, 12 Ton (estimated) Heating coil.	Mix 30% Min	6.WS6 8am-4pm M-F
HV12	Metal shop	9000 (est.)	7.5 (est.)	-	Heating coil	Mix 20% Min	50200.SCH 5am-4:30 M-F
HV13	Counselling	6000 cfm	5	1.5	Heating coil.	Mix 30% Min	1.WS1 CO2 sensor in return
HV14	800 Block	6000 cfm	5	1.5	Heating coil.	Mix 30% Min	1.WS1 CO2 sensor in return

**Table 5: Exhaust fans**

Tag	Service	Airflow (l/s)	Fan
EF1	Male washrooms	380	0.25 HP
EF2	Female washrooms	380	0.25 HP
EF3	Foods	1120	½ HP
EF4	EF805	1415	-
EF4A	Staff washrooms	94	123 W
EF5		300	10.4 Amps
EF5A	Multi-purpose storage	300	242 W
EF7	Male washroom	124	147 W
EF8	Female washroom	300	242 W
EF9	Gym change rooms		
EF10	Staff washrooms 400 wing		
EF1 CP301	-		
EF2 CP301	-		
EF3 CP301	-		

Tag	Service	Airflow (l/s)	Fan
SHOP EF1	-		VSD
SHOP EF2	-		VSD
SHOP EF4	-		VSD
EF 805	200 Wing staff washroom		10.4 Amps

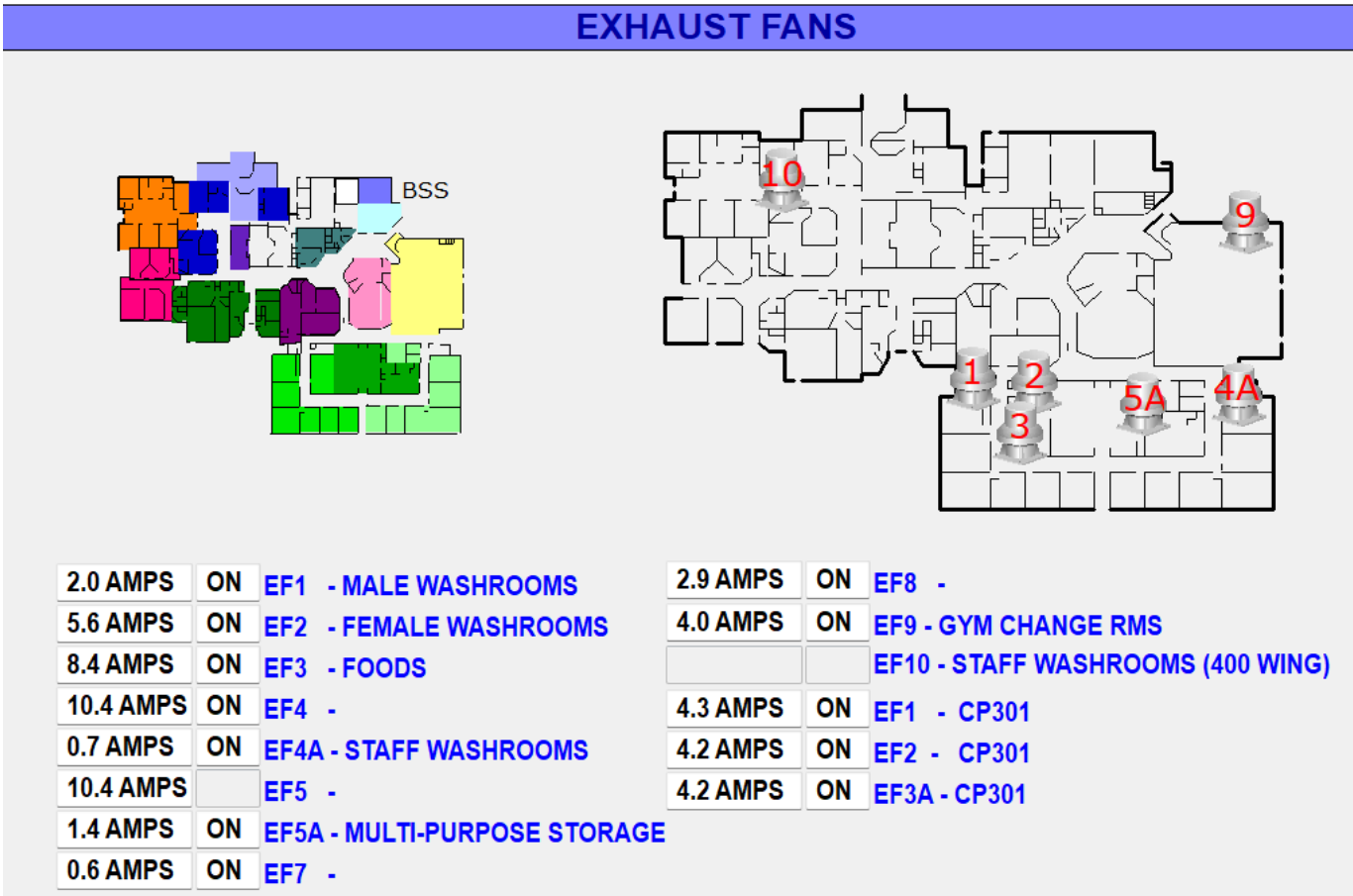

Figure 6: Exhaust fans in the DDC

### 4.5 Domestic Hot Water System

The school has two domestic hot water (DHW) systems, each serving part of the building. The first is a 199 MBH (input) 378 liter gas-fired tank heater, and recirculation pump.

The second is a 30 kW 420 liter electric water heater, with recirculation pump.

### 4.6 Controls System

The HVAC system is controlled by a Delta Controls DDC with ORCAView 3.40. Remote access to the system is available. Boilers, pumps, HV-5, HV8, HV-12 use the BACnet protocol. Other systems use the older "V2" protocol.



## BALLENAS SECONDARY SCHOOL

<input checked="" type="checkbox"/>	HV1A (MULTI)	HV11 (GYM)	<input checked="" type="checkbox"/>
<input type="checkbox"/>	HV2 (OFFICE and 200 WING)	HV12 (METAL)	<input type="checkbox"/>
<input type="checkbox"/>	HV2A (900 EAST)	V13 (COUNSEL and 701,702)	<input type="checkbox"/>
<input type="checkbox"/>	AHU3 (300BLK)	HV14 (800)	<input type="checkbox"/>
<input type="checkbox"/>	HV3A (900 WEST)	DHWR	
<input type="checkbox"/>	AHU4 (LIB 602 605)	BOILER SYSTEM	<input type="checkbox"/> OFF
<input type="checkbox"/>	HV4 (700)	PUMPS	
<input type="checkbox"/>	AHU5 (WELDING)	DHW	
<input type="checkbox"/>	HV5 (WOOD)	EXHAUST FANS	
<input type="checkbox"/>	HV8AC8(400)	NETWORK	
<input type="checkbox"/>	HV9 (TECH)	E1 (SHOP)	
<input checked="" type="checkbox"/>	HV10 (AUDITORIUM)	E2 (SHOP)	
<input checked="" type="checkbox"/>	HV11A (WEIGHT RM)	E4 (SHOP)	

Schedule 1.WS1	<input type="checkbox"/> ON
Schedule 1.WS4	<input type="checkbox"/> OFF
Schedule 2.WS4	<input type="checkbox"/> ON
Schedule 4.WS1	<input checked="" type="checkbox"/> ON
Schedule 6.WS3	<input checked="" type="checkbox"/> ON
Schedule 6.WS4	<input checked="" type="checkbox"/> ON

BSS

PREVIOUS HELP NETWORK FLOOR PLAN

Figure 7: Main menu of the DDC system

## 5.0 Measures Selected for Implementation (Under C.Op. Program)

This section provides an overview of each measure, recommendations for implementation, and update after implementation.

For each measure, costs, savings, and payback calculations can be referenced in the *Investigation Summary Table* (see Appendix A).

### 5.1 Measure 1: Reheat coils

#### 5.1.1 Description of Finding

Several reheat coils and their control valves were found to be blocked or passing, see Table 6.

Passing valves result in excessive zone heating. Blocked valves can also cause increased heating because the air handler needs a higher supply air temperature to maintain the setpoint in affected zones. This may result in overheating other zones which do not require extra heating.

**Table 6: Reheat coil issues**

Air handler	Blocked	Passing	Comments
HV1A		RM914B, RM914C	
HV2	RM203, RM116, COPY153, VP, PRINCIPAL, RM145		All reheats set manually to 50%  RM201/2 reheats have failed SAT sensors
HV2A	RM908, RM911, RM913, RM915		
AHU3	303	301, 304	
HV3	LAB603, LAB OFF603, LOCKERS, CHEM STO.		All reheats set manually to 50%.
HV3A	RM904, RM906	RM901A, RM907	RM920 suspected blocked, RM919 suspected passing based on room temperatures.
AHU4	OFFICE605, CHEM605		BIO 601, LIB, LIB EAST also seem low.  Valve position set to 50% in code.
HV8AC8	404B, 405		
HV10		Stage duct heating coil	
HV11A	Main AHU coil		
HV13	160, 162, 159	157	
HV14	801, 803, 804, 805		Only 803 is completely blocked

Documentation for reheat problems can be found in Appendix E: Reheat Coils.

AHU-3 reheat coil issues shown here as an example. AHU-3's supply air temperature is 17.3°C at the time Figure 8 was captured. Where reheat coil control valves are fully closed, the reheat coil supply air temperatures should equal the AHU-3 supply air temperature. However, reheat coil supply air temperatures for rooms 301 and 304 are 23.1 and 20.8°C respectively, despite the control valves being fully closed. This suggests the control valves are passing.

The reheat for room 303 is increasing the air temperature to 19.1°C but failing to meet the supply air setpoint (20.1°C) even with the valve almost fully open. AHU-3 is supplying air too hot for rooms 300 and 305. This may be due to Room 303 failing to meet setpoint.

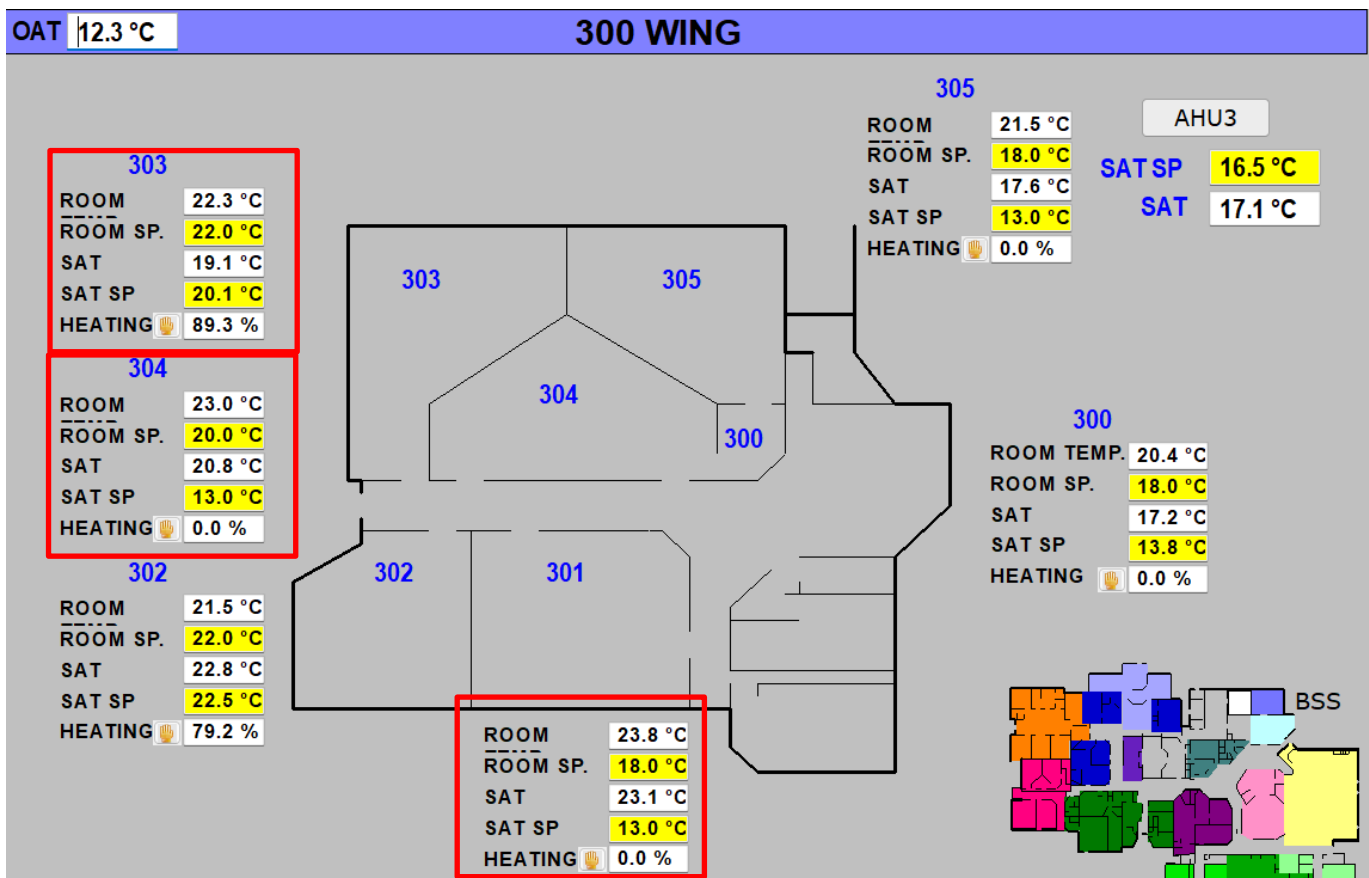

Figure 8: Reheats for 301 and 304 are passing. Reheat for 303 is partly blocked.

### 5.1.2 Measure Description

We recommend investigating of all reheat coils in the building to identify coils/valves with issues and diagnosing the issue (valve, coil, or actuator). Some cases may be solved with maintenance, but we expect some valves to need replacement.

This is a required measure since degrading or failing valves/coils will eventually lead to comfort issues.

### 5.1.3 Measure Implementation Update

[Provide confirmation details **AFTER** the measure is implemented and verified]

## 5.2 Measure 2: Fan feedback sensor

### 5.2.1 Description of Finding

The HV10 and HV11 supply fan feedback sensors report that the fans operate despite being commanded off, see Figure 9.

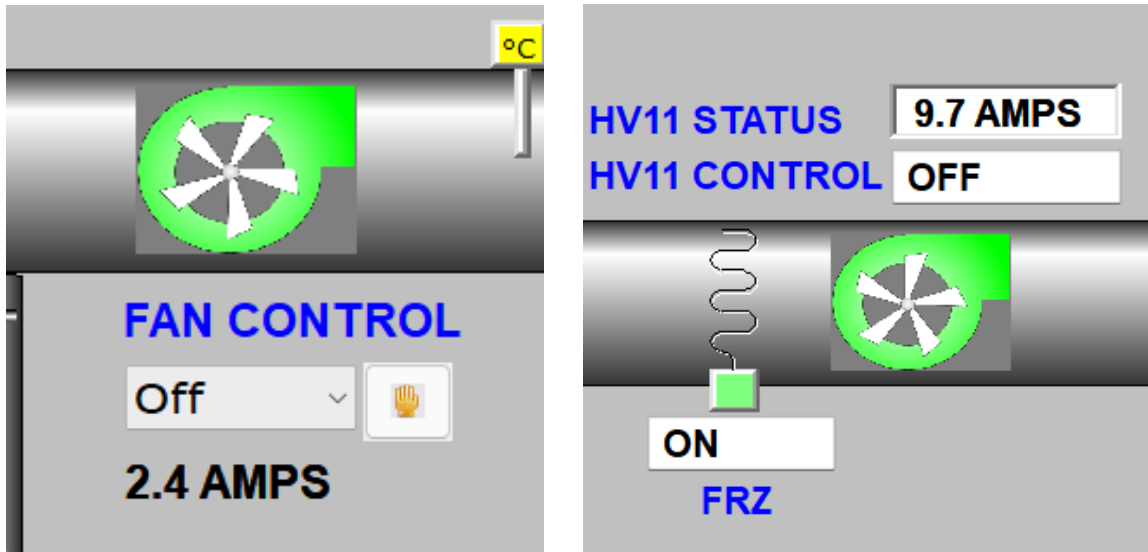

Figure 9: HV10 (left) and HV11 (right) supply fans

The HV10 supply fan sensor reports 2.4 A when commanded off. This triggers regular operation of the unit, including opening the MAD to its minimum setting (30%), and modulating the heating coils to maintain regular occupied setpoints in the auditorium.

The sensor reports a similar current when the fan is commanded on, which indicates it may be operating continuously.

```

22 ● IF HV10_WS OR HV10_OVR OR BUILDING_FLUSH OR H10_ENHANCED_WS THEN
23 ●   HV10_SFC = ON
24 ● ELSE
25 ●   NSB_HV10 = SWITCH(NSB_HV10 , HV10_RT1 , NSB_SP , NSB_SP + 2 )
26 ●   HV10_SFC = NSB_HV10
27 ● ENDF HV10_SFC = OFF
    
```

Figure 10: HV10\_SFC set to OFF

```

33 ● IF HV10_SFS > 1 THEN
34 ●   DO_EVER HV10_SFS = 2.5
35 ●   HV10_MAD_RAMP = LIMIT(HV10_MAD_RAMP + (HV10_RAT - 18) , 0 , 100 )
36 ● ENDDO
37 ● H10_MAT_SP = 12
38 ● HV10_MAD = HSEL(HV10_MAD_MIN , HV10_SAT_CO )
39 ● HV10_MAD = LSEL(HV10_MAD , HV10_MAD_LL_CO , HV10_MAD_RAMP )
    
```

Figure 11: Fan feedback value HV10\_SFS indicates significant current going to the fan

HV10\_MAD\_TL (6.TL11) Trend Log

On [Hand icon] 22:25:47 18-May-2022

Main Setup Trend Data

Time	HV10_SAT	HV10_SAT_SP	HV10_MAD	HV10_SFS
22:25.47	15.0	28.0	30.0	2.5
22:25.17	15.0	28.0	30.0	2.5
22:24.47	15.0	28.0	30.0	2.5
22:24.17	15.1	28.0	30.0	2.5
22:23.47	15.0	28.0	30.0	2.5
22:23.17	15.0	28.0	30.0	2.5
22:22.47	15.0	28.0	30.0	2.5
22:22.17	15.0	28.0	30.0	2.5
22:21.47	15.0	28.0	30.0	2.5
22:21.17	15.0	28.0	30.0	2.5
22:20.47	15.0	28.0	30.0	2.5
22:20.17	15.1	28.0	30.0	2.5
22:19.47	15.0	28.0	30.0	2.5
22:19.17	15.0	28.0	30.0	2.5
22:18.47	15.1	28.0	30.0	2.5
22:18.17	15.1	28.0	30.0	2.5
22:17.47	15.1	28.0	30.0	2.4
22:17.17	15.1	28.0	30.0	2.5
22:16.47	15.1	28.0	30.0	2.5
22:16.17	15.2	28.0	30.0	2.5
22:15.47	15.1	28.0	30.0	2.5

Figure 12: Value of HV10 fan feedback sensor

HV11 which serves the gym has the same issue. The sensor reports 9.8 Amp when commanded off, and 17.8 Amps when commanded on, so it is likely this is a sensor function or calibration issue.

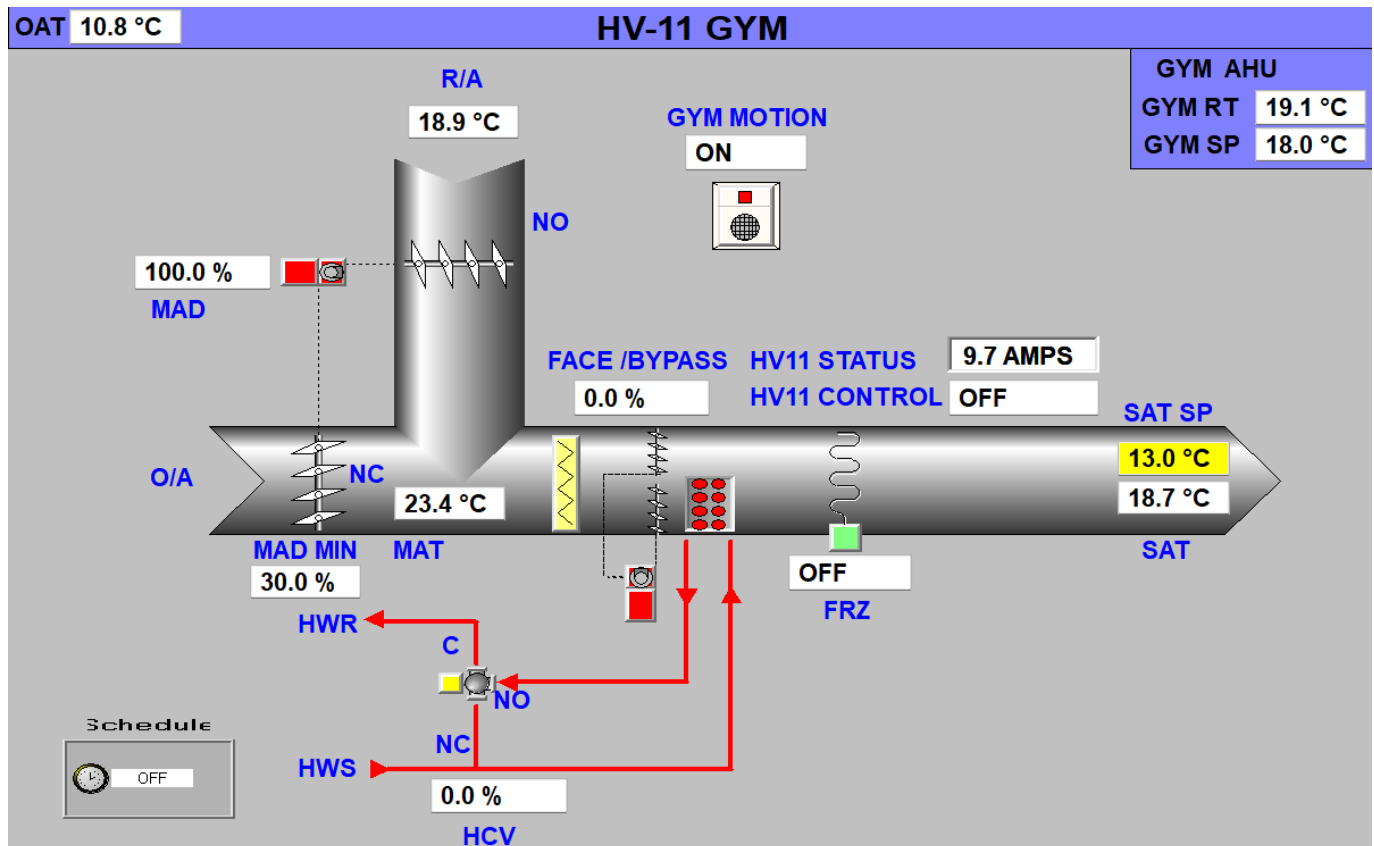

Figure 13: HV11 supply fan feedback is 9.7 Amps even when the fan is commanded off

The air handler operates as normal if the supply fan reports it's running, including opening the mixed air damper and heating valve, which can lead to heat losses even if there is no airflow.

```

30 ● IF GYM_SFS > 5 THEN
31 ● DO_EVER GYM_SFS = 9.7
32 ● GYM_MAD_RAMP = LIMIT ( GYM_MAD_RAMP + ( GYM_RAT - 17 ) , 0 , 100 )
33 ● ENDDO
34 ● GYM_MAT_SP = 8
35 ● GYM_MAD_LL_CO.BIAS = 0
36 ● GYM_MAD = HSEL ( GYM_MAD , GYM_MAD_MIN , ( ( OCC_SAT_CO - 50 ) * 2 ) )
37 ● GYM_MAD = LSEL ( GYM_MAD , GYM_MAD_LL_CO , GYM_MAD_RAMP )
38 ●
39 ● [HEATING CONTROL]
40 ●
41 ● GYM_HCV = 100 - ( OCC_SAT_CO * 2.1 )
    
```

Figure 14: HV1 operates as normal if the supply fan feedback indicates the fan is running

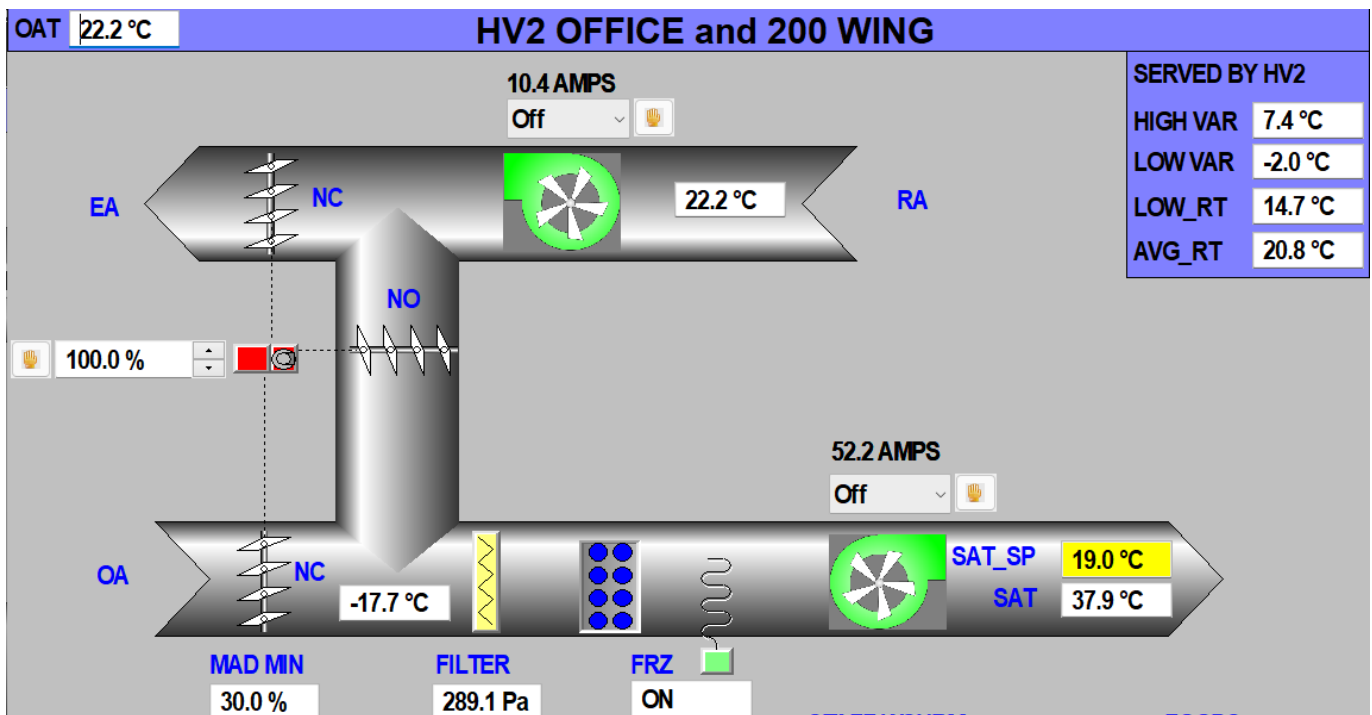

Figure 15: HV2 supply and return fans sensors both indicate fans are running when commanded off

### 5.2.2 Measure description

Verify the HV10 and HV11 supply fan feedback sensors correctly reports that status of the fan by manually checking fan status in the field while commanding the fans on and off.

Savings calculations assume the HV10 controller is faulty (i.e., HV10 operates when commanded off), and the HV11 fan sensor requires replacement.

## 5.3 Measure 3: Morning schedules

### 5.3.1 Description of Finding

Air handlers HV5, HV9, HV12 start at 5am, well before occupancy.

### 5.3.2 Description of Measure

Change start times of these air handlers to 7am, Monday to Friday. Ensure that units are operating correctly, including correcting HV5 heating coil and loop issues, see Measure 5.7.

## 5.4 Measure 4: Night setback temperatures

### 5.4.1 Description of Finding

Lowering room temperature setpoints during unoccupied periods (commonly known as “night setback”) reduced heat losses without affecting comfort during occupied hours. Most night setback temperature setpoints in the building are around 19°C. This is too high to provide significant energy savings.

**Table 7: Night setback temperatures**

Tag	NSB (°C)
HV1A	19
HV2	15
HV2A	19 (NSB_SP)
AHU3	15
HV3	19
HV3A	19
AHU4	19
HV4	15
AHU5	19 (SHOP_NSB_SP)
HV5	20
HV8AC8	19 (NSB203_SP)
HV9	
HV10	19 (NSB_SP)
HV11A	0
HV11	14
HV12	14 (HV12_NSB_SP)
HV13	16 (P301_NSB)
HV14	16 (P303_NSB)

HV5 incorrectly uses the mixed air damper setpoint value in the night setback calculation, see Figure 16. Since this value is fixed to 30% (Figure 17), night setbacks are never enabled for HV5.

$$4 \bullet HV5\_NSB = Switch ( HV5\_NSB, HV5\_DC\_MAD\_SP, HV5\_NSB\_SP - 1, HV5\_NSB\_SP )$$

**Figure 16: HV5 night setback calculation**

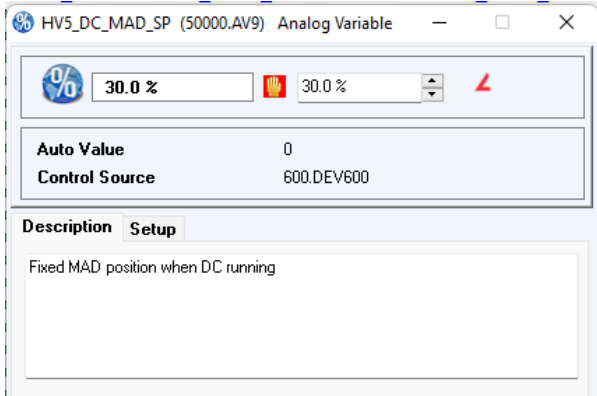

Figure 17: HV5 mixed air damper setpoint is manually set to 30%

### 5.4.2 Measure Description

Lower night setbacks to 15°C for all air handlers.

Correct HV5 night setback programming to use room temperature.

## 5.5 Measure 5: Holiday schedule

### 5.5.1 Description of Finding

The holiday schedules for spring and summer breaks do not match the actual school calendar. The spring break schedule is offset from actual weekdays. The summer break schedule only covers part of July and August.

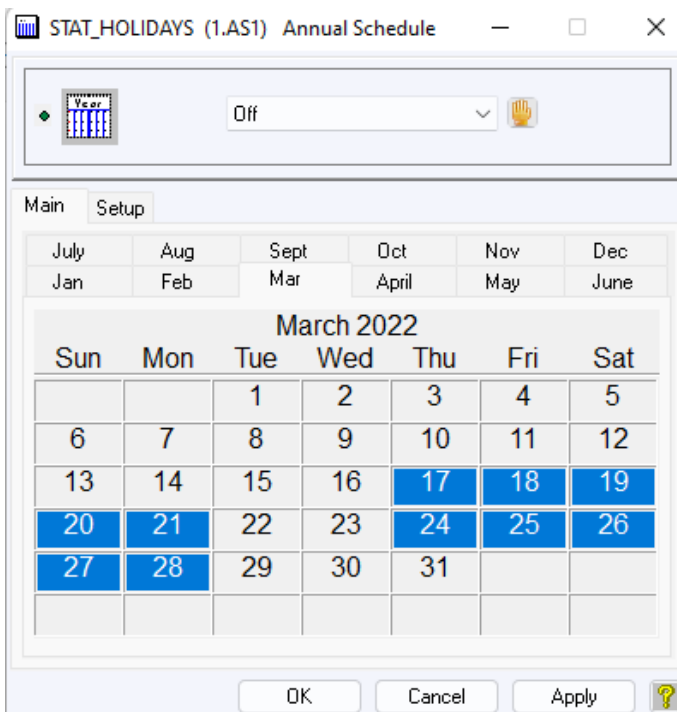
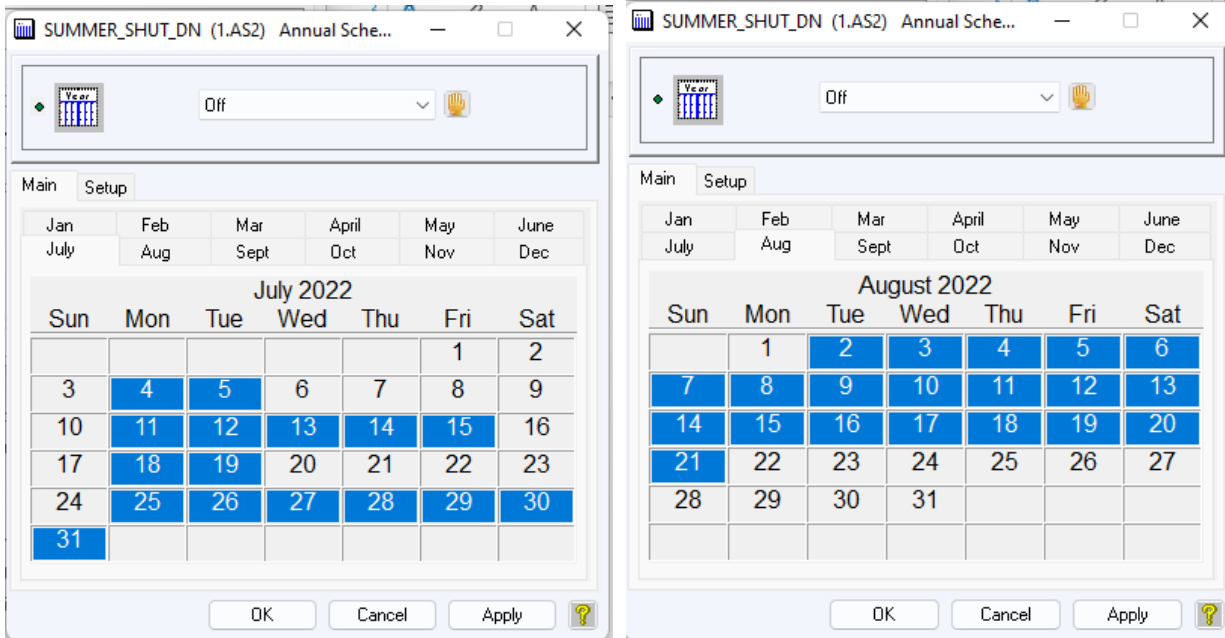

Figure 18: Spring break exception schedule





**Figure 19: Summer break exception calendar**

In comparison, Gym and Auditorium have summer break schedules that cover all of July and August, which saves energy during an unoccupied period.

**5.5.2 Measure Description**

Update holiday schedules for all air handlers to match school calendar on a regular basis.

**5.5.3 Measure Implementation Update**

[Provide confirmation details **AFTER** the measure is implemented and verified]

**5.6 Measure 6: Exhaust Fans run outside occupied periods**

**5.6.1 Description of Finding**

Several exhaust fans were found to be running while the building was unoccupied, see Figure 21. Unless there are specific needs, such as moisture/pollutant control, they should be switched off when the building is unoccupied.

EF1 and EF2 are overridden on. This causes them to operate continuously.

EF4, EF5, and EF9 feedback sensors show each operates when commanded off.

EF7 and EF8 are operating continuously. Both are programmed to operate per weekly occupancy schedules that no longer exist in the DDC as seen in Figure 20.

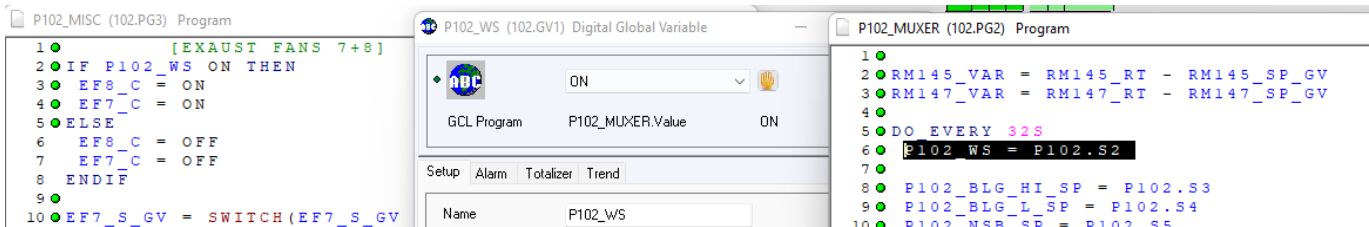

**Figure 20: EF7 and EF8 calendar logic**

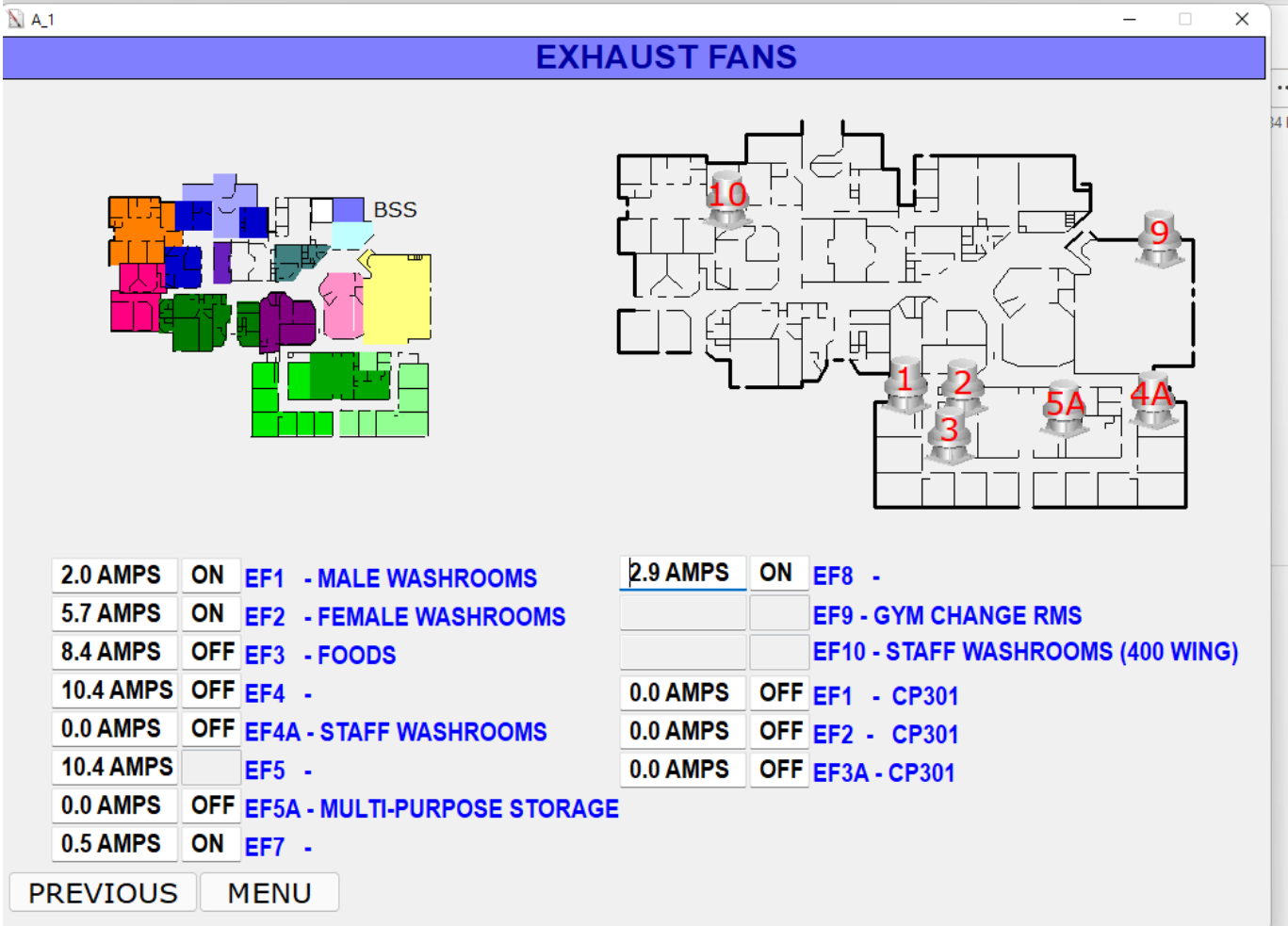

Figure 21: Exhaust fans overview, at 10:24pm on a Sunday

### 5.6.2 Measure Description

Remove overrides for EF1 and EF2. Correct schedule logic for EF7 and EF8.

Verify correct operation of EF4, EF5, and EF9 fans and the feedback sensors in the field. Replace the sensors or control wiring as indicated by field tests.

Predicted energy savings assume EF1, EF2, EF7, and EF8 currently operate continuously. Estimated measure costs assume EF4, EF5, and EF9 feedback sensors need to be replaced.

### 5.6.3 Measure Implementation Update

[Provide confirmation details **AFTER** the measure is implemented and verified]

## 5.7 Measure 7: HV5 temps and heating coils

### 5.7.1 Description of Finding

HV-5 is struggling to meet its supply air and zone temperature setpoints despite its heating coil control valve fully open as seen in Figure 22.

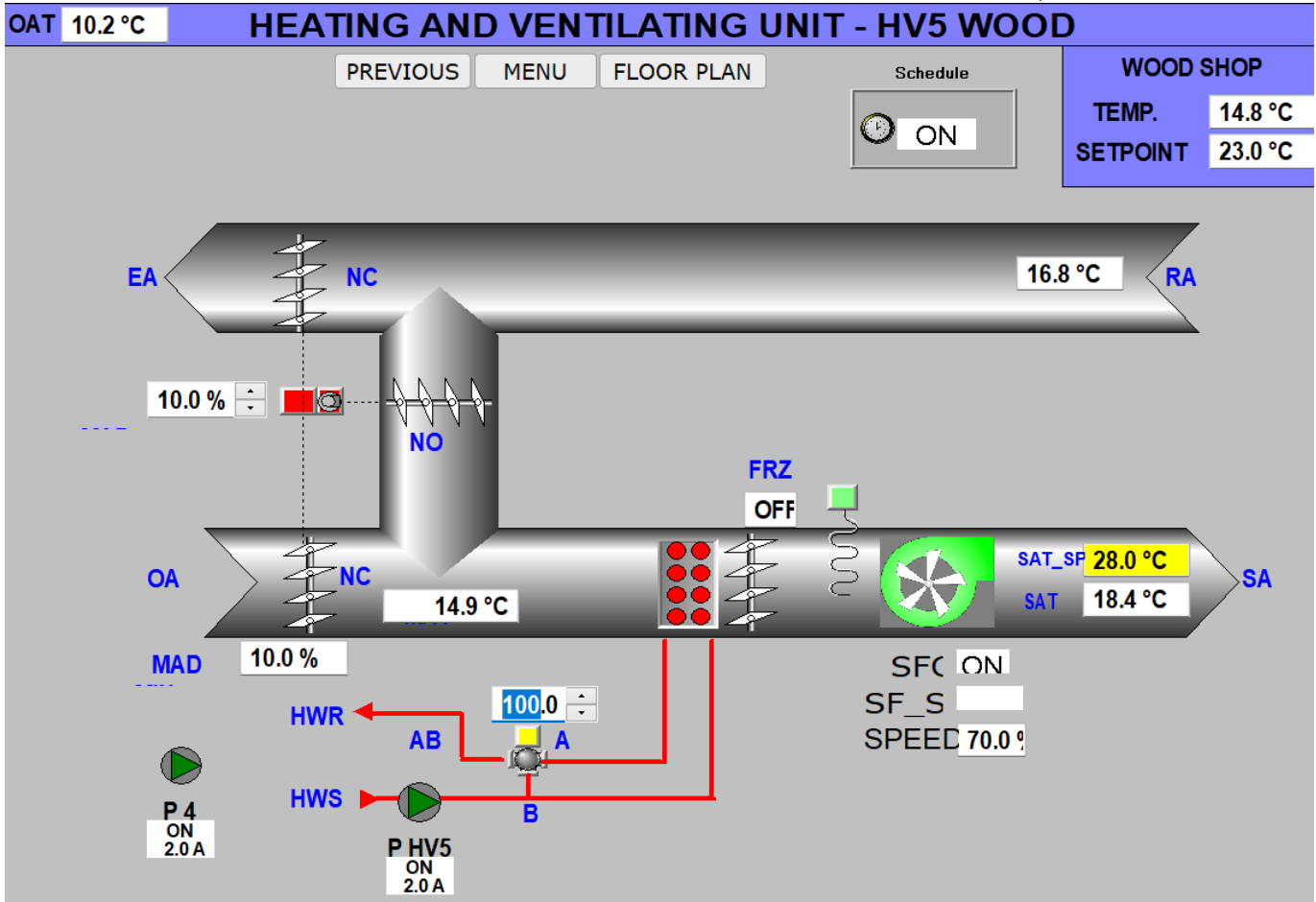

Figure 22: HV-5 has low supply air temperature even with heating valve fully open

### 5.7.2 Measure Description

Investigate HV5 heating loop and coil and confirm correct operation. Correct any issues.

### 5.7.3 Measure Implementation Update

[Provide confirmation details **AFTER** the measure is implemented and verified]

## 5.8 Measure 8: Temperature sensors

### 5.8.1 Description of Finding

Several supply air and room temperature sensors are providing incorrect readings, see Table 8.

Low supply air temperature readings can cause unnecessary reheat. Low room temperature readings can cause unnecessary reheat as well as overnight “night setback” operation of air handlers.

**Table 8: Temperature Sensor Issues**

Sensor	Issue / constant reading
RM201 supply air temperature	Constant value (-17.1°C)
RM202 supply air temperature	Constant value (-17.1°C)
RM203 supply air temperature	Constant value (-17.1°C)
RM201	Constant value (14.7°C)
RM202	Constant value (18.1°C)
RM203 room temperature	Constant value (22.7°C)
RM116 room temperature	Constant value (18.5°C)
ART ROOM room temperature	Constant value (23.3°C)
RM911 room temperature	Constant value (17.7°C)

RM203_SAT	-17.7	DEG_C	1.IP11	Analog	Input
RM201_SAT	-17.7	DEG_C	1.IP14	Analog	Input
RM202_SAT	-17.7	DEG_C	1.IP15	Analog	Input

**Figure 23: Supply air temperature sensor values**

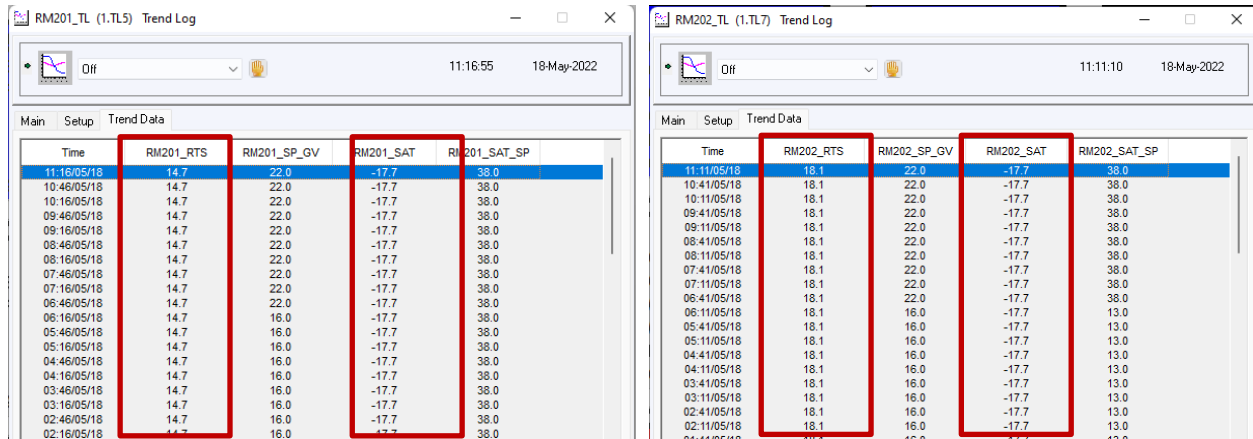

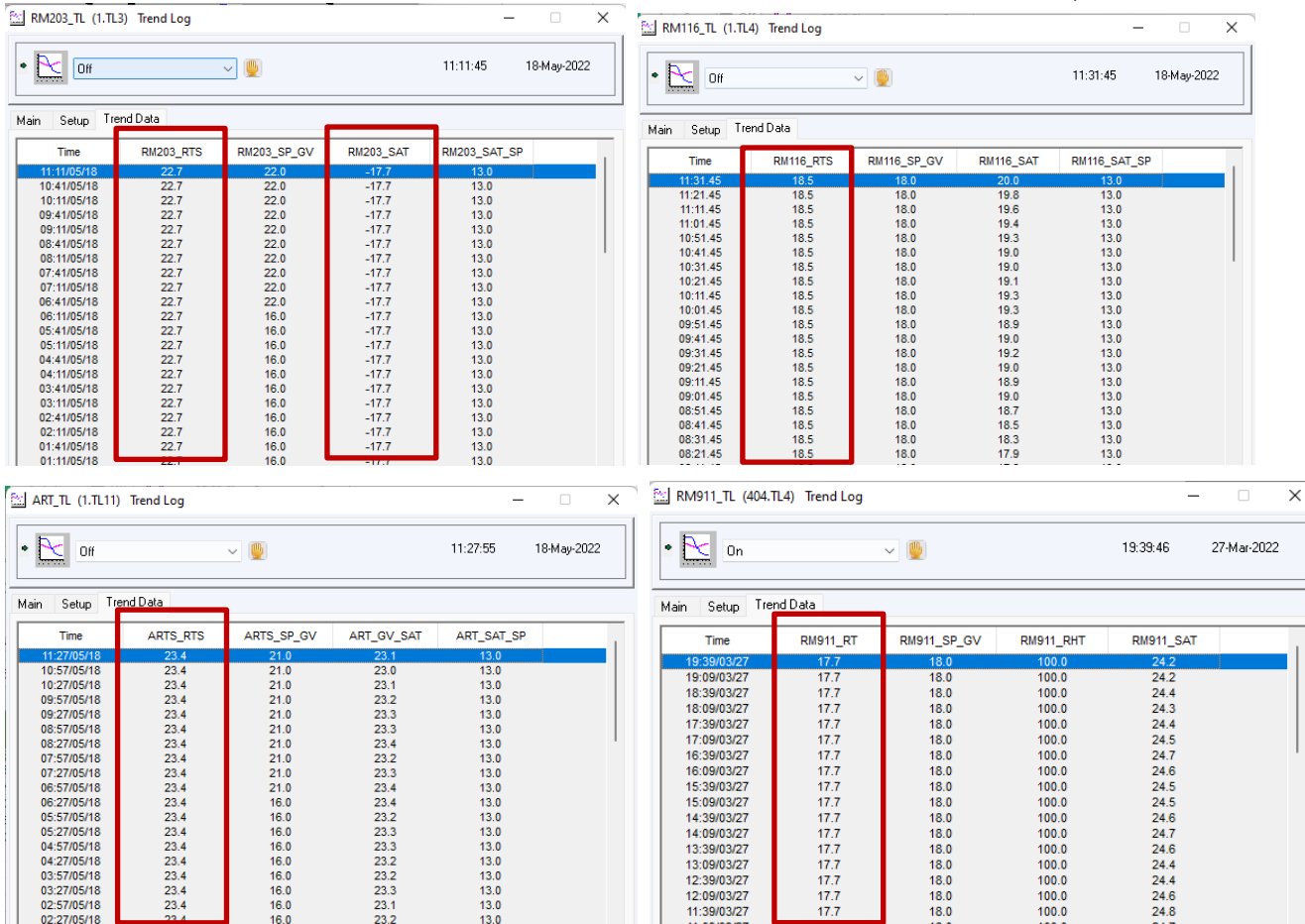

**Figure 24: Failed room temperature and SAT sensors for RM201, 202, 203, 116, ART ROOM, 911**

The RM911 room temperature sensor is stuck at 17.7°C which is lower than NSB SP (19°C). During the investigation period, the low RM911 room temperature was observed to trigger HV2A to run during unoccupied times.

```

46 ● IFONCE (HV2A_RFS > 5) THEN
47 ●   HV2A_MAD_RAMP = 0
48 ● ENDIF
49 ●
50 ●   [**SYSTEM START-UP MODE** ]
51 ● IF CP1_WS ON OR HV2A_OS ON OR BUILDING_FLUSH OR H2A_ENHANCED_WS
52 ●   HV2A_RFC = ON
53 ●   HV2A_NSB_GV = OFF
54 ● ELSE
55 ●   HV2A_NSB_GV = SWITCH(HV2A_NSB_GV , HV2A_LOW_RT , NSB_SP , \C
56 ●   NSB_SP + 1 )
57 ●   HV2A_RFC = HV2A_NSB_GV
58 ● ENDIF
59 ●
60 ● IF (HV2A_RFS > 2) ON_FOR 10S THEN
61 ●   HV2A_SFRC = ON
62 ● ELSE

```

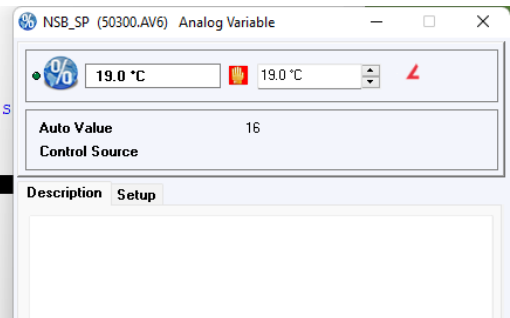

**Figure 25: HV2A night setback logic**

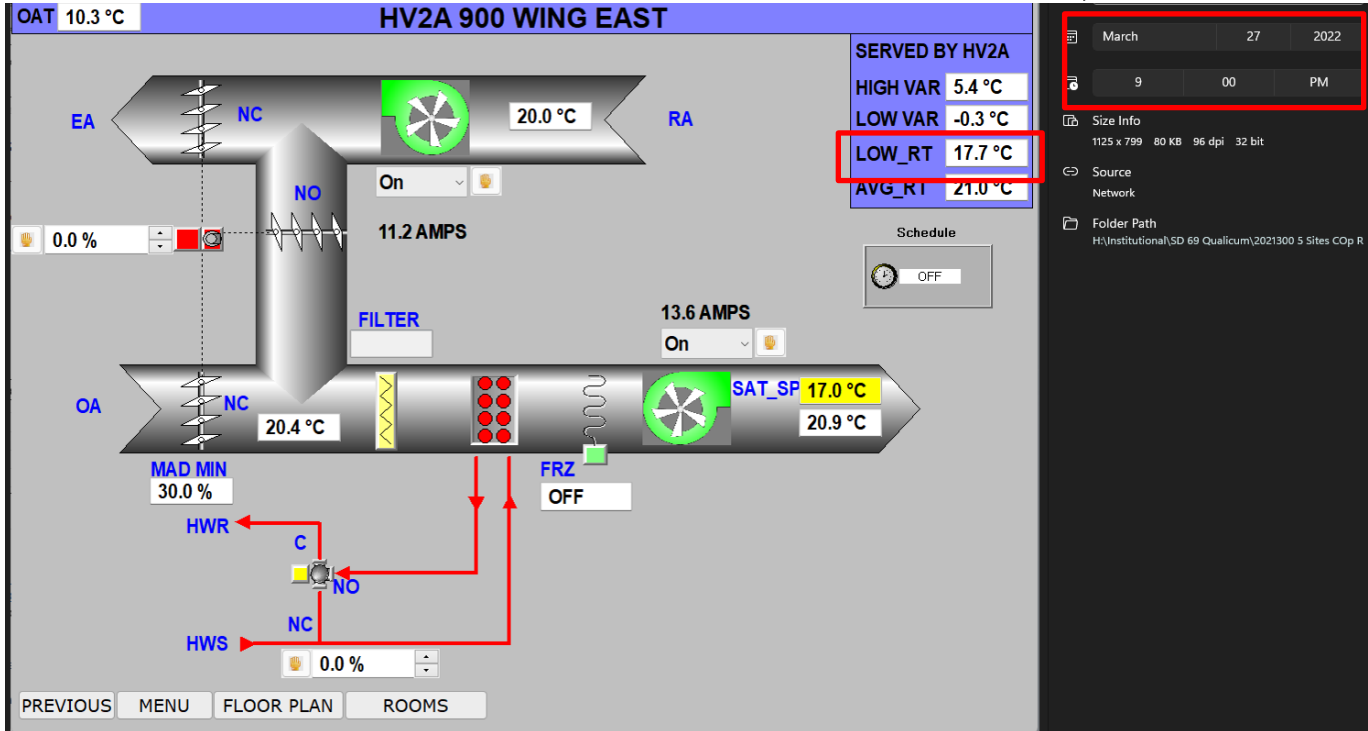

Figure 26: HV2A operating outside scheduled hours

### 5.8.2 Measure Description

Replace the problem temperature sensors.

### 5.8.3 Measure Implementation Update

[Provide confirmation details **AFTER** the measure is implemented and verified]

## 6.0 Measures to be considered for Future Implementation

This section provides an overview of each measure (that was identified but **was not selected** as part of this C. Op. project, but maybe considered for future implementation), recommendations for implementation, and the most suitable method for providing evidence of implementation. See Appendix A - Investigation Phase Summary Table for more details.

### 6.1 Measure 9: Reversible heat pumps for existing DX coils

Approximately 35% of the school has mechanical cooling from DX coils in air handlers and supply ducts.

When these DX systems reach end-of-life, they can be upgraded to reversible heat pumps of similar capacity. This will enable them to provide 1<sup>st</sup> stage heating, supplemented by heating coils like the existing ones. Our high-level estimate is that new replacement units would cover all the heating needs for areas served by these air handlers.

**Table 9: Existing DX systems**

Tag	Size	Age	Description	Replacement
HV2	23 Ton 9500 cfm	Pre-1996	Packaged roof-top unit (Lennox DMS4-275HW) with DX coil and hydronic heating coil	Similar sized unit with reversible heat pump
HV4	6 Ton 2000 cfm	2001	Packaged roof-top unit (Trane TFD075) with DX coil, hydronic heating coil	Similar sized unit with reversible heat pump
HV8AC8	28 Ton 10,000 cfm	1991	Air handler (Engineered Air FWA-285-C). Air inlet and outlets, condensing coils and fans are in a small courtyard. The rest of the unit is in a mechanical room.	Similar sized unit with external condensing unit.
HV11A	12 Ton 2,400 cfm		Packaged roof-top unit with DX coil and hydronic heating coil	Similar sized unit with reversible heat pump
CU-1 to CU-4	4 Ton condensing units	2001	Rooftop condensing units (Trane TTA048) with indoor coils in supply air ducts leading to four classrooms in 900 block.	Similar sized reversible units



**Figure 27: HV2 and HV4 rooftop units with DX cooling**



Figure 28: HV11A rooftop unit with DX cooling

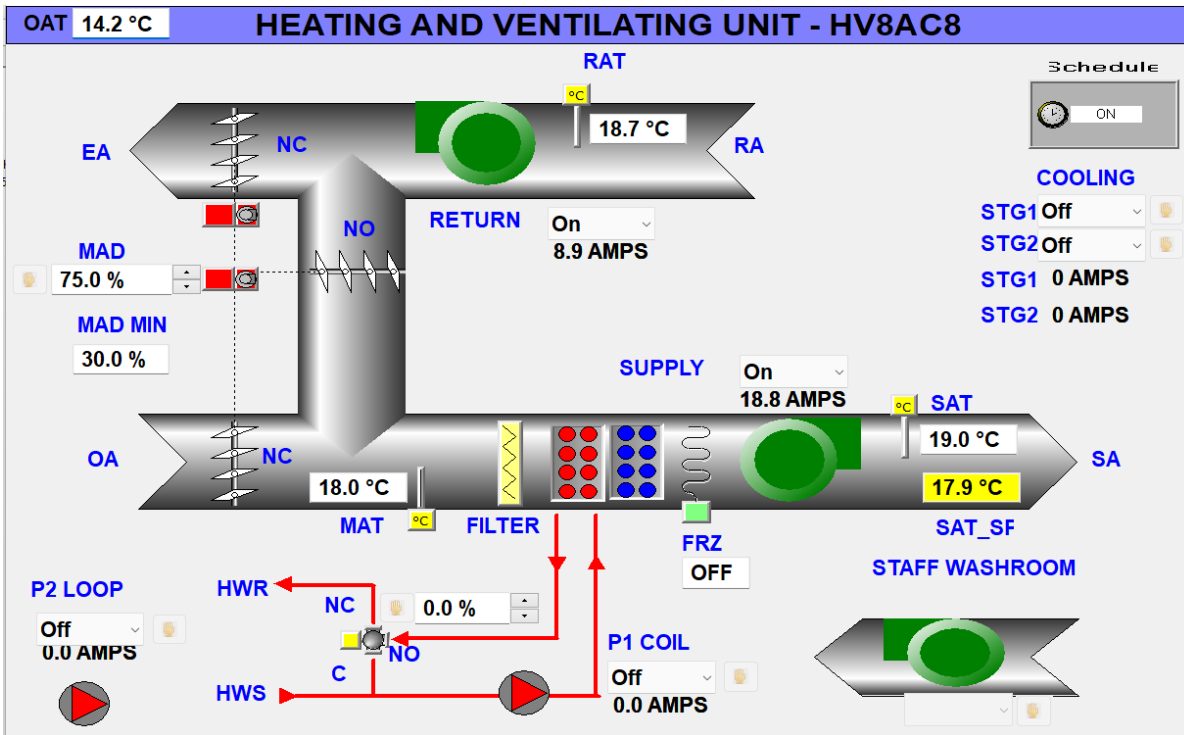
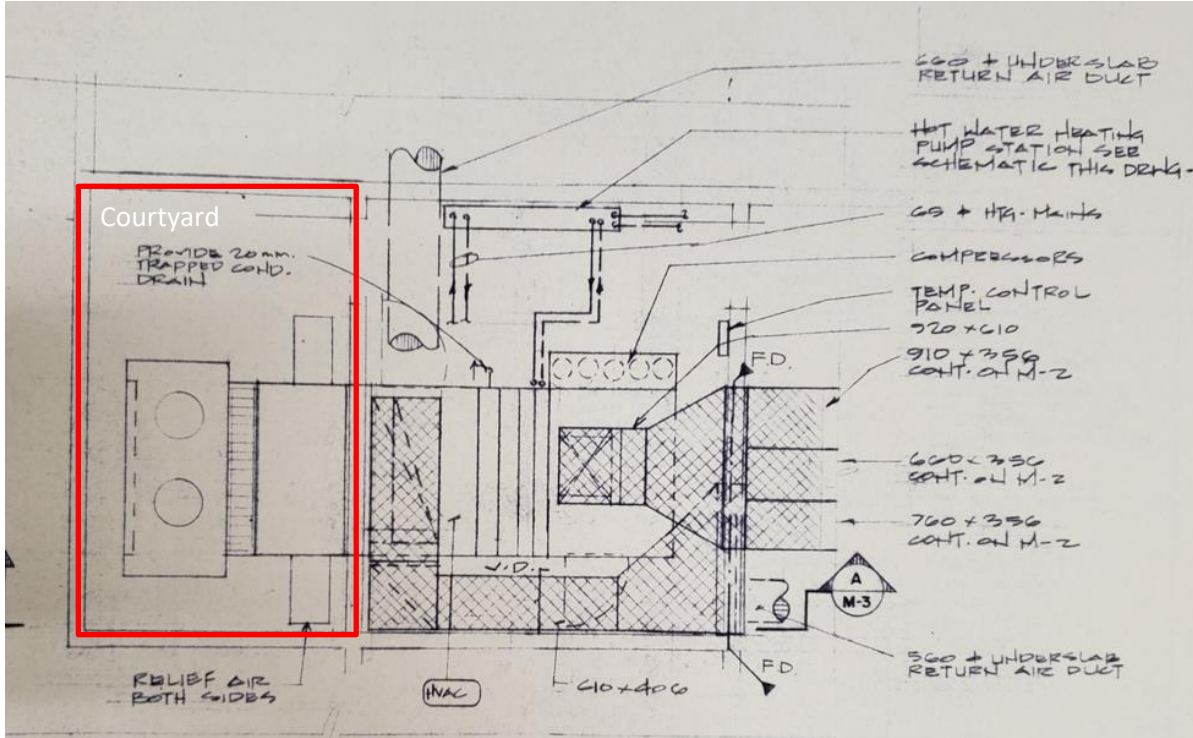

Figure 29: HV8AC8 in the DDC. The unit has two stages of cooling.





**Figure 30: Drawing of HV8AC8. The main unit is inside Mechanical Room 110. The condensing unit is outside in a small courtyard area**

Four 4-ton split systems provide cooling to classrooms 901, 903, 912, and 913 using dx coils in the ducts from HV2A and HV3A.

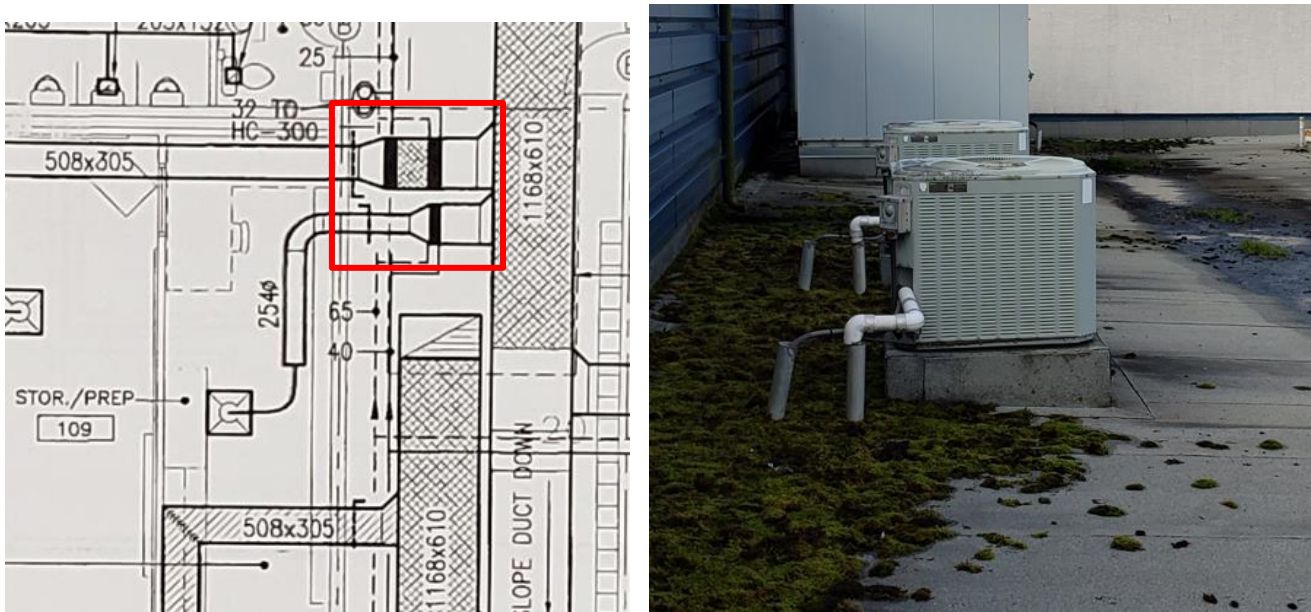

**Figure 31: DX coils and outdoor units provide cooling to four rooms in the 900 Block.**

CU-1 to CU-4 (Figure 31: DX coils and outdoor units provide cooling to four rooms in the 900 Block.) would be relatively simple swaps with equivalent reversible units.

Estimated measure costs include all work required to replace each existing cooling system with a reversible heat pump. The base case cost (replacing the equipment like-for-like) may be similar. The ASHRAE life expectancy for air cooled condensers is 20 years, so these units should need to be replaced in 5 to 10 years.

A feasibility study is recommended as the next step to assessing the viability of this project. Mechanical and structural assessments are required to refine the cost and viability of the project.

The study can be expanded to consider the feasibility of adding DX coils to other air handlers in the school, including determining which units would provide the most cost-effective emissions reduction. One benefit of this solution is the addition of cooling to other parts of the school.

## 6.2 Measure 10: Hydronic Air Source Heat Pump

An alternative low carbon electrification strategy is to supplement the existing hydronic heating system with an air source heat pump. Commercially available air source heat pumps can heat water up to 50°C efficiently. With the current boiler control logic, the supply water would be too warm for the heat pumps to provide much heating once outdoor temperatures drop below 9.5°C. In the Qualicum climate, only 10% of heating needs occur above this temperature. In general, the system would need to operate with 50°C supply water temperatures down to 4°C outdoor temperatures to meet 50% of heating needs, and down to 0°C to meet 75% of heating needs.

We recommend testing lower supply water temperatures during the next heating season, after ensuring that all coils are performing as specified (see Measure 1: Reheat coils). Performing this test in different conditions or adding long term trending and analytics for continuous monitoring, will provide realistic data regarding the changes to the system (mainly upgrades to heating coils) that are required before heat pumps become a viable solution.

Adding heat pumps to the heating loop will only provide significant benefits if the hydronic system can be made to operate with water loop temperatures at 50°C (or less) down to freezing conditions, which covers approximately 75% of heating needs in the Qualicum climate.

## 7.0 Next Steps – Implementation Phase and Completion Phase

### 7.1 Implementation Phase

To continue in the program, the owner is responsible for implementing the selected bundle of measures that pay back in two years or less. Using the *Recommissioning Report* for implementation allows flexibility in how the selected measures are implemented. Options include: utilize in-house building staff, hire the C.Op Provider to implement or provide technical assistance, contract with outside service contractors, or any combination of the above.

### 7.2 Completion Phase

C.Op Service provider will follow up after implementation of the selected measures and **update** this *Recommissioning report and Recommissioning Workbook*.

The updated report for the implemented measures includes but not limited to: date of completion of each measure, new or improved sequences of operation, the energy savings impact of the measures, the requirements for ongoing maintenance and monitoring of the measures, and contact information for the service provider, in



house staff, and contractors responsible for the implementation. When feasible, verification data should include trends or functional test results, though other methods, such as copies of invoices, site visit reports, and before/after photos, may be acceptable.

The C.Op Service Provider will conduct an in-house (teleconference) session for the Applicant and the appropriate building operations personnel covering the new documentation, measures that were implemented, and requirements for ongoing maintenance and monitoring. Document the attendance of the building operations staff.

The *updated Recommissioning Workbook* and *updated Recommissioning Report* will be submitted to the owner and the program for review. See Appendix B: Completion Phase Summary Table for more details on implemented measures.

## Appendix A: Investigation Phase Summary Table

Investigation Phase Summary				Investigation Phase							
ECM #	Measure Title	Measure History	Include cost	Energy Savings			Cost Savings	Financial		Est. GHG Reduction	Enter "x" if DESELECT for implementation
				Demand (kW)	Electrical (kWh/yr)	Fuel (GJ)	Total (\$/yr)	Estimated Measure Cost (\$)	Simple Payback (yrs)	tonnes CO2e/yr	
ECM-1	Reheat coils	New	1	-	-	394	\$ 4,782	\$ 14,400	3.0	19.7	
ECM-2	AHU Fan controls	New	1	-	18,896	179	\$ 4,029	\$ 800	0.2	9.1	
ECM-3	Morning schedule	New	1	-	5,606	81	\$ 1,536	\$ 600	0.4	4.1	
ECM-4	Night setbacks	New	1	-	-	172	\$ 2,079	\$ 1,100	0.5	8.6	
ECM-5	Holiday schedules	New	1	-	17,730	29	\$ 2,100	\$ 400	0.2	1.6	
ECM-6	Exhaust fans	New	1	-	5,222	235	\$ 3,362	\$ 1,400	0.4	11.8	
ECM-7	HV5 heating coil valve	New	1	-	-	-	\$ -	\$ 2,400	#DIV/0!	-	
ECM-8	Temperature sensors	New	1	-	-	-	\$ -	\$ 2,200	#DIV/0!	-	
ECM-9	Reversible heat pumps for existing DX coils	New	1	- 50	- 128,290	1,539	\$ 6,005	\$ 373,425	62.2	75.4	x
TOTAL (Previous, still working):				-	-	-	\$ -	n/a	n/a	-	
TOTAL (All potential measures for Implementation):				- 50	- 80,837	2,629	\$ 23,893	\$ 396,725	16.6	130.2	
TOTAL (Selected measures only):				-	47,454	1,090	\$ 17,888	\$ 23,300	1.3	54.8	

## Appendix B: Completion Phase Summary Table

[Paste image of Completion Summary Table from the RCx Workbook AFTER Implementation]

## Appendix C: Sample Training Outline

### [Completion Report AFTER Implementation]

The Commissioning Provider (C.Op Provider) may customize the outline for the training and developing the training materials. Before preparing the training outline and materials, the C.Op Provider should assess the related level of knowledge of the building operators, to set up the training accordingly. For reference, the Program provides the following sample outline for the training:

- Background on the energy use of this particular building
  - Present Energy Utilization Index
  - Describe Operating Schedules and Owner's operating requirements
- RCx investigation process used in this building
  - Describe the methods used to identify problems and deficiencies
  - Review the RCx Workbook
- Implementation process in this building
  - Describe the measures that were implemented and by whom
  - Walk around the building to look at any physical changes or step through the new control sequences at the operator workstation
  - Provide as many details about implementation as necessary to describe what was done
  - Describe improved performance that these measures will create (show trends if available)
- O&M requirements
  - Describe the O&M requirements needed to keep these improvements working
  - Describe how the staff can be aware of energy efficiency opportunities and begin looking for additional savings potential

The C.Op Provider should follow the outline to prepare materials, as necessary, to hand out at the training session.



## Appendix D: Training Completion Form

Project ID
------------

### Facility Information

Company Name	Building Name(s)
Facility Address	City Province

### Training Details

Location	Date
Commissioning Provider/Trainer	

### Materials Attached

<input type="checkbox"/> Agenda
<input type="checkbox"/> Materials used for training
<input type="checkbox"/> List of individuals who attended

#### COMMISSIONING PROVIDER SIGNATURE

By signing this Training Completion Form, I verify that this training took place with the listed attendees.	
Commissioning Provider (print name):	
Signature:	Date:

**FACSIMILE/SCANNED SIGNATURES:** Facsimile transmission of any signed original document, and the retransmission of any signed facsimile transmission, shall be the same as delivery of the original signed document. Scanned original documents transmitted to BC Hydro as an attachment via electronic mail shall be the same as delivery of the original signed document. At the request of BC Hydro, C.Op Provider shall confirm documents with a facsimile transmitted signature or a scanned signature by providing an original document.



Targeted Documentation

O & M Manual

O & M Manual updated <input type="checkbox"/>	Describe updates below and attach copies of new or amended portions
O & M Manual not updated <input type="checkbox"/>	Province reasons below
Building has no O & M Manual <input type="checkbox"/>	

Building Plans (“as-builts”)

Building Plans updated <input type="checkbox"/>	Describe below
Wiring diagrams updated <input type="checkbox"/>	Describe below
No plans or diagrams updated <input type="checkbox"/>	Describe below

EMS Programming

New sequences of operation on file <input type="checkbox"/>	Specify location of file and attach copy
Printed screenshots on file <input type="checkbox"/>	Specify location of file and attach copy

Equipment Manuals

Manuals for new equipment are on file <input type="checkbox"/>	Describe below (attach copy if applicable)



We're working together to help B.C. save energy.





# Appendix E: Reheat Coils

## HV1A

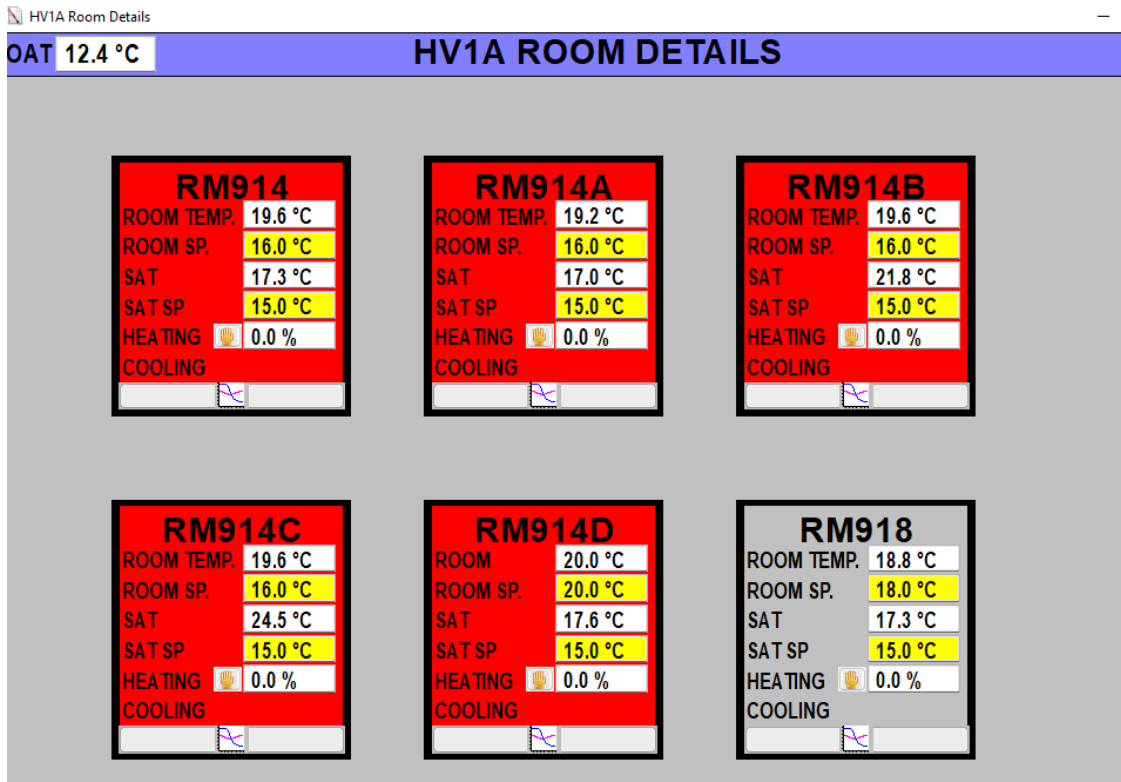
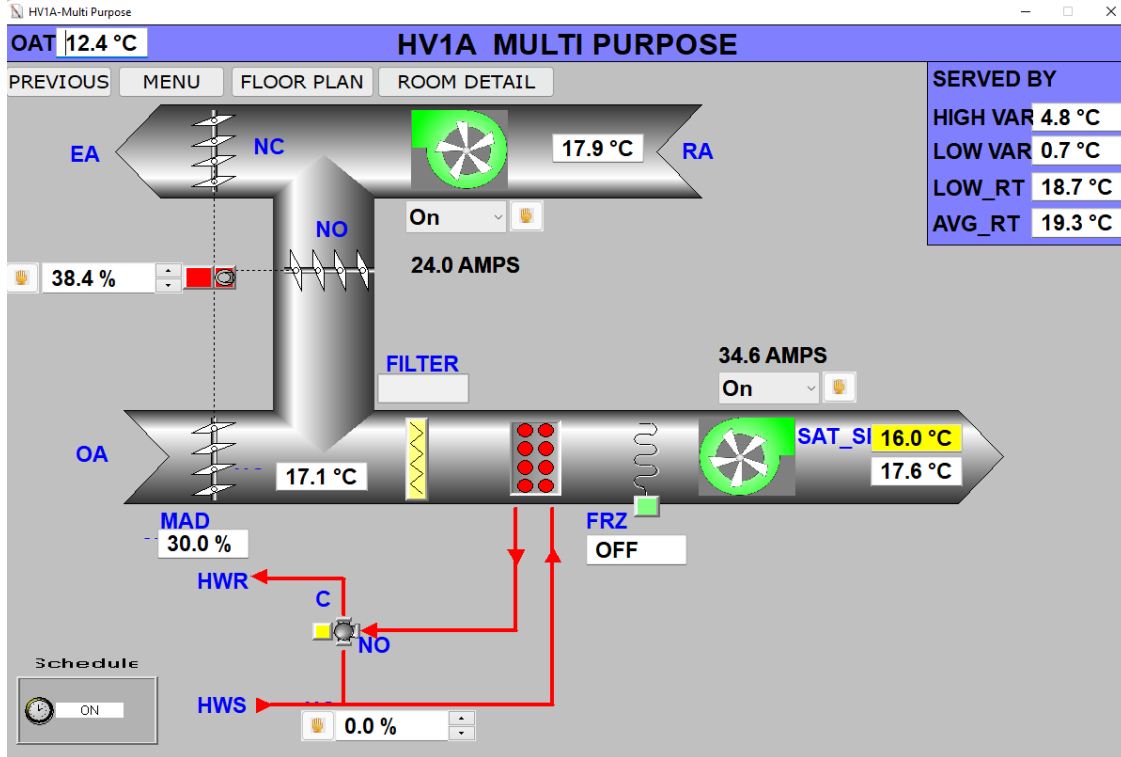

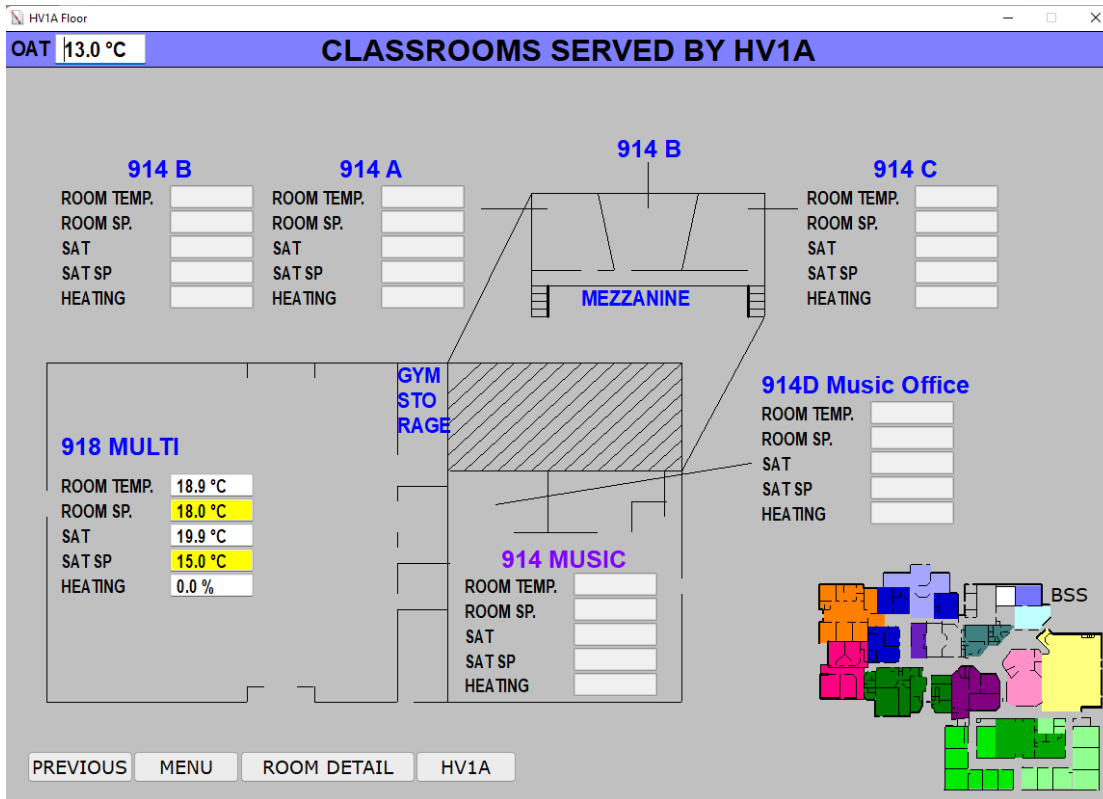

**HV2**

SAT from AHU 17.9C at time of review

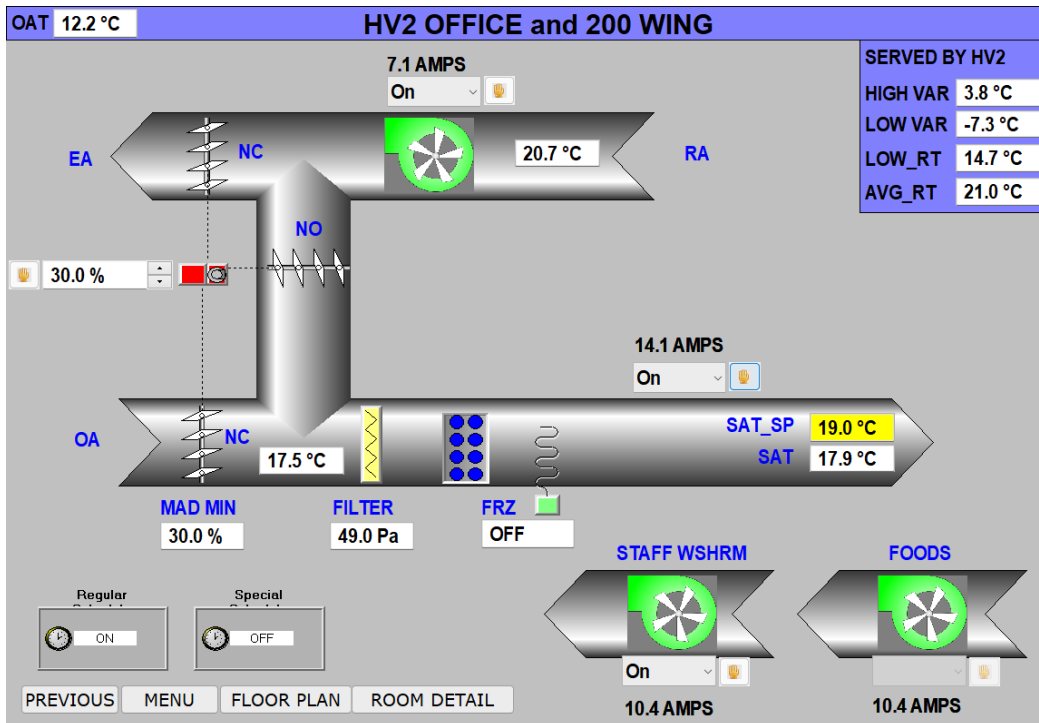

OAT 12.2 °C **HV2 ROOM DETAILS**

<b>RM201</b> ROOM TEMP. 14.7 °C ROOM SP. 22.0 °C SAT -17.7 °C SAT SP 38.0 °C HEATING 50.0 % COOLING	<b>RM202</b> ROOM TEMP. 18.1 °C ROOM SP. 22.0 °C SAT -17.7 °C SAT SP 38.0 °C HEATING 50.0 % COOLING	<b>RM203</b> ROOM TEMP. 22.7 °C ROOM SP. 22.0 °C SAT 17.9 °C SAT SP 22.0 °C HEATING 50.0 % COOLING	<b>RM116</b> ROOM TEMP. 18.5 °C ROOM SP. 18.0 °C SAT 18.1 °C SAT SP 13.0 °C HEATING 50.0 % COOLING
<b>COPY153</b> ROOM TEMP. 20.1 °C ROOM SP. 20.0 °C SAT 18.0 °C SAT SP 30.7 °C HEATING 50.0 % COOLING	<b>V.P.</b> ROOM TEMP. 23.0 °C ROOM SP. 22.0 °C SAT 18.1 °C SAT SP 13.0 °C HEATING 50.0 % COOLING	<b>PRINCIPAL</b> ROOM TEMP. 22.9 °C ROOM SP. 22.0 °C SAT 18.1 °C SAT SP 18.3 °C HEATING 50.0 % COOLING	<b>ADMIN</b> ROOM TEMP. 24.2 °C ROOM SP. 23.0 °C SAT 29.1 °C SAT SP 13.0 °C HEATING 50.0 % COOLING
<b>RM145</b> ROOM TEMP. 23.8 °C ROOM SP. 20.0 °C SAT 18.4 °C SAT SP 15.0 °C HEATING 0.0 % COOLING	<b>RM147</b> ROOM TEMP. 20.0 °C ROOM SP. 22.0 °C SAT 27.9 °C SAT SP 35.0 °C HEATING 100.0 % COOLING	<b>ART ROOM</b> ROOM TEMP. 23.4 °C ROOM SP. 21.0 °C SAT 22.7 °C SAT SP 13.0 °C HEATING 50.0 % COOLING	

OAT 13.2 °C **CLASSROOMS SERVED BY HV2**

<b>203</b> ROOM 22.7 °C ROOM 22.0 °C SAT -17.7 °C SAT SP 13.0 °C HEATING 50.0 %	<b>V Prin RM 153</b> ROOM TEMP 20.5 °C ROOM SP. 20.0 °C SAT 20.0 °C SAT SP 13.0 °C HEATING 50.0 %	<b>V.P.</b> ROOM TEMP 21.5 °C ROOM SP. 22.0 °C SAT 20.6 °C SAT SP 13.0 °C HEATING 50.0 %	<b>HV2</b> SAT_SP 19.0 °C SAT 19.7 °C
<b>116</b> ROOM 18.5 °C ROOM 18.0 °C SAT 20.0 °C SAT SP 13.0 °C HEATING 50.0 %	<b>CLASSROOM 202</b> ROOM 18.1 °C ROOM 22.0 °C SAT -17.7 °C SAT SP 13.0 °C HEATING 50.0 %	<b>CLASS ROOM 201</b> ROOM 19.6 °C ROOM 22.0 °C SAT 19.3 °C SAT SP 38.0 °C HEATING 50.0 %	<b>STAFF ROOM 147</b> 22.0 °C 17.7 °C
<b>201</b> ROOM 14.7 °C ROOM 22.0 °C SAT -17.7 °C SAT SP 38.0 °C HEATING 50.0 %	<b>ADMIN</b> 21.1 °C	<b>PRINCIPAL</b> 23.0 °C	<b>STORAGE 145</b> 20.0 °C 21.9 °C

[PREVIOUS](#)
[MENU](#)
[ROOM DETAIL](#)
[HV2](#)

FLOOR PLAN

**HV2A**

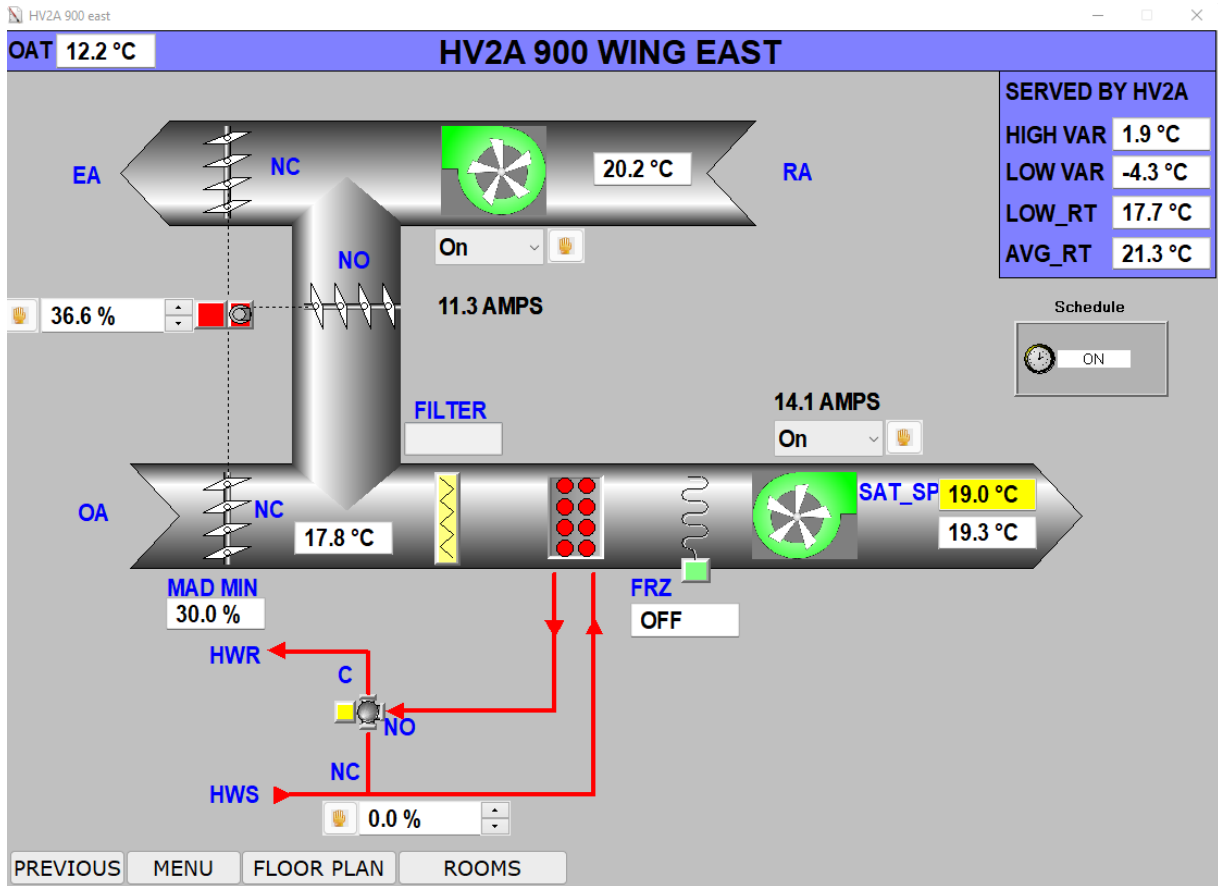

HV2A Room Details

OAT 12.2 °C

### HV2A ROOM DETAILS

Room ID	Room Temp	Room SP	SAT	SAT SP	Heating %	Cooling
RM908	21.9 °C	22.0 °C	19.3 °C	29.2 °C	100.0 %	OFF
RM909	22.3 °C	22.0 °C	19.2 °C	16.2 °C	0.0 %	OFF
RM910	21.5 °C	20.0 °C	19.6 °C	15.0 °C	0.0 %	OFF
RM911	17.7 °C	22.0 °C	21.9 °C	35.0 °C	100.0 %	OFF
RM912	21.9 °C	22.0 °C	19.6 °C	16.8 °C	0.0 %	OFF
RM913	21.9 °C	22.0 °C	18.6 °C	27.6 °C	100.0 %	OFF
RM915	21.9 °C	22.0 °C	19.7 °C	20.0 °C	31.3 %	OFF
RM916	20.8 °C	21.0 °C	22.8 °C	35.0 °C	100.0 %	OFF
RM917	21.9 °C	20.0 °C	19.0 °C	15.0 °C	0.0 %	OFF
RM924	19.1 °C	19.0 °C			OFF	OFF
RM925	19.2 °C	19.0 °C			OFF	OFF
RM926	18.9 °C	17.0 °C			OFF	OFF

PREVIOUS MENU

### AHU3

OAT 12.2 °C

### AHU3 300 WING

Regular Schedule: ON | Special Schedule: ON

SPD FB: 10.70 A | SPD: 100.0% | ENAB: On

MAD: 68.3 % | CO2: 779.7 ppm

FRZ: OFF | SAT: 17.3 °C

RAT: 20.6 °C | SWT: 33.5 °C

HCV: 53.5% | RWT: 24.3 °C

0.4 AMPS | On

PREVIOUS MENU FLOOR PLAN

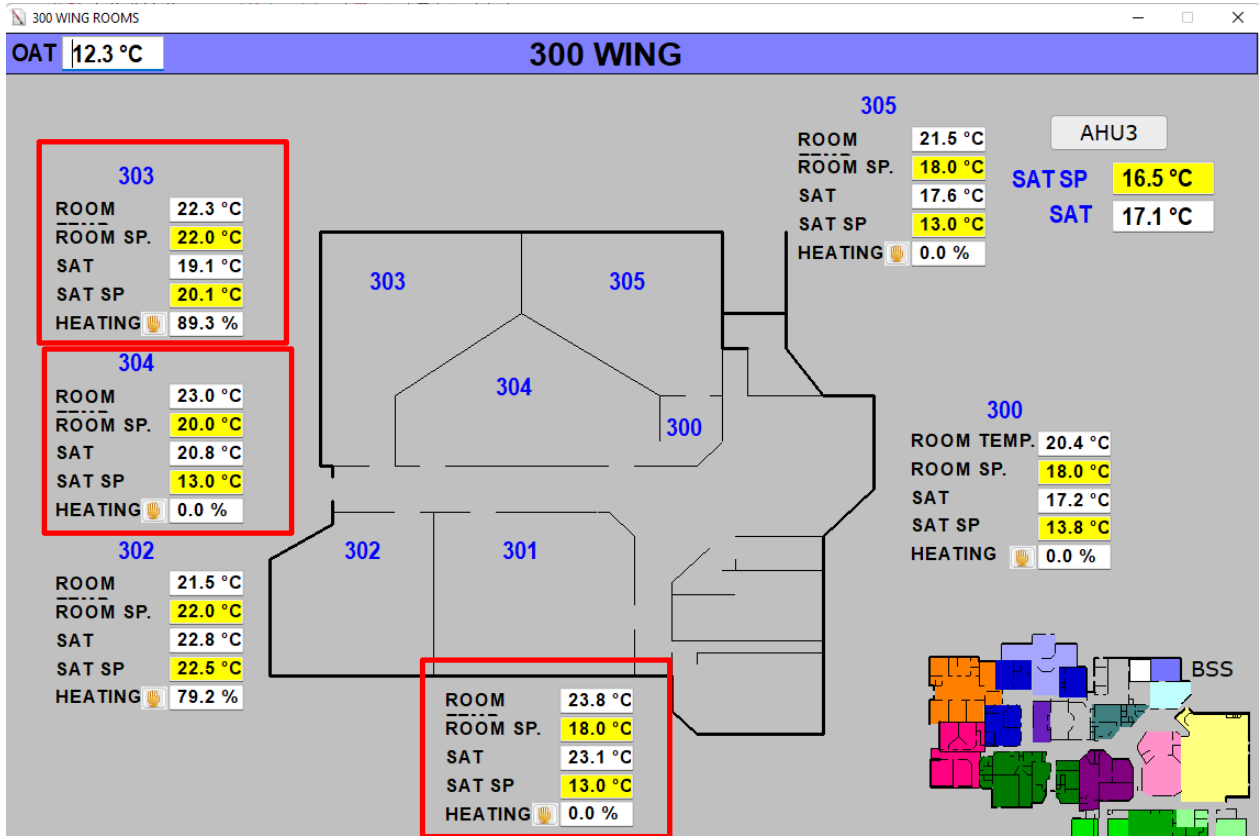



**HV3**

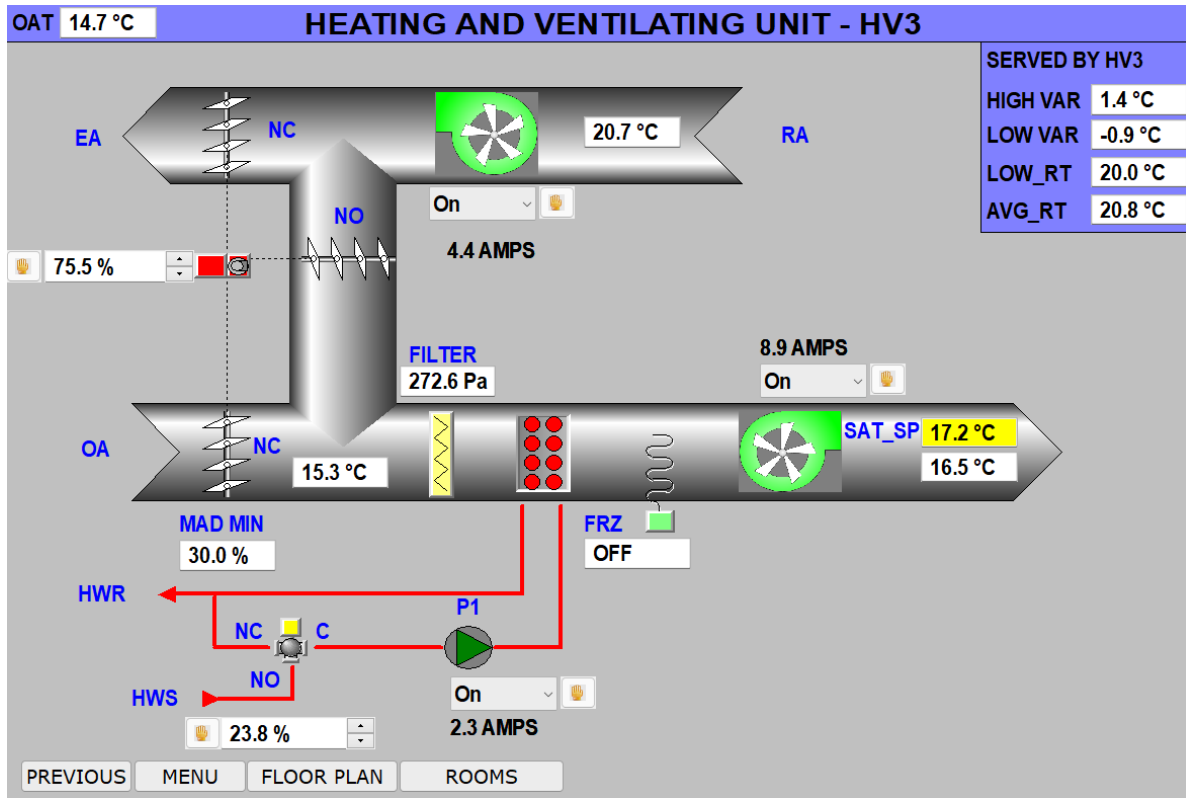

HV3 Room Details

OAT 14.7 °C

### HV3 ROOM DETAILS

Room Name	Room Temp	Room SP	SAT	SAT SP	HEATING	COOLING
PHYSIC602	21.9 °C	23.0 °C	23.5 °C	33.0 °C	50.0 %	
LAB 603	20.4 °C	19.0 °C	16.7 °C	13.0 °C	50.0 %	
LAB OFF.603	20.0 °C	19.0 °C	17.0 °C	13.0 °C	50.0 %	
LOCKERS	20.7 °C	18.0 °C	16.7 °C	13.0 °C	50.0 %	
LAB 604	21.1 °C	21.0 °C	24.1 °C	30.1 °C	50.0 %	
CHEM STO.	20.4 °C	19.0 °C	17.2 °C	13.0 °C	50.0 %	

PREVIOUS MENU HV3 FLOOR PLAN

**HV3A**

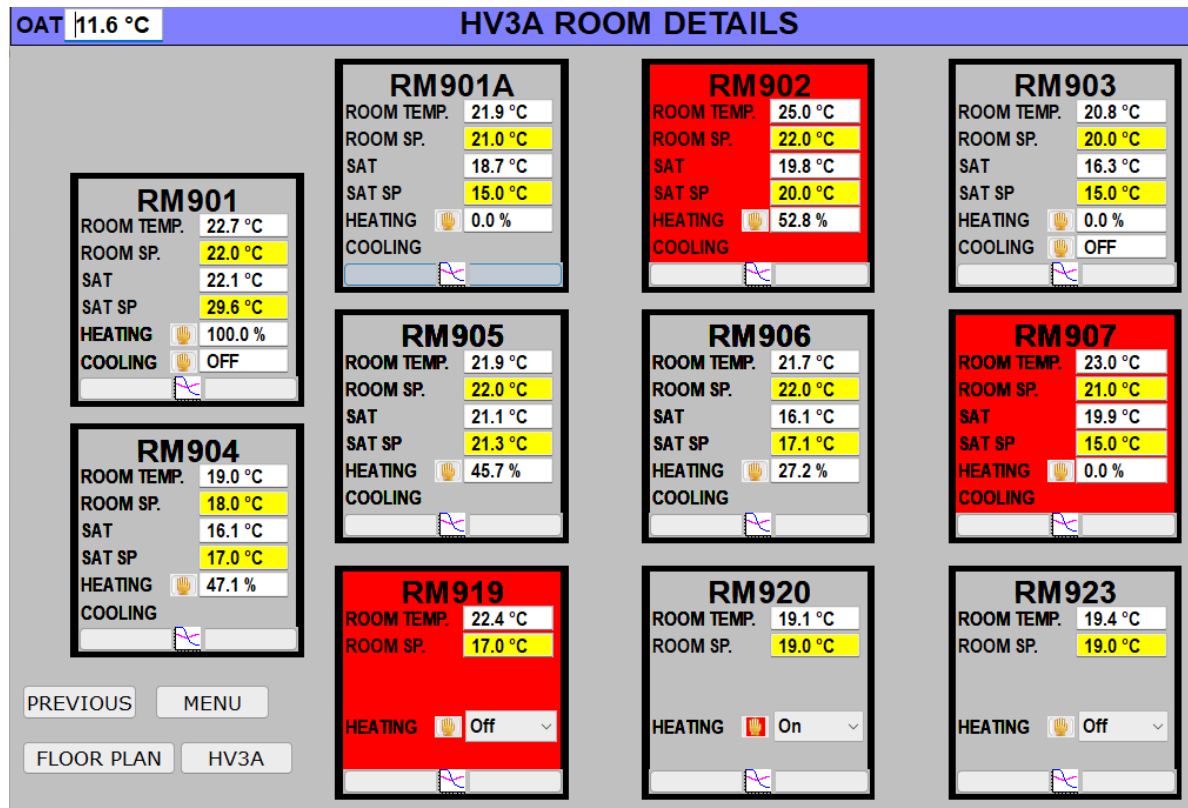
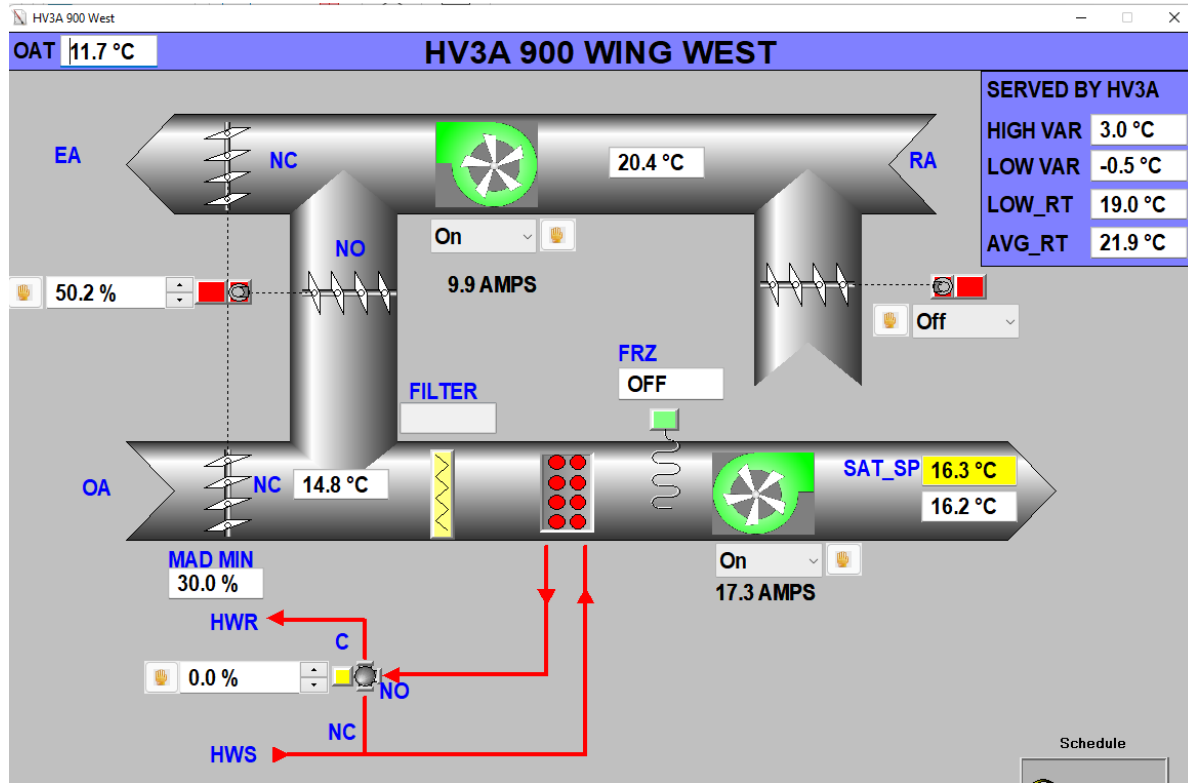

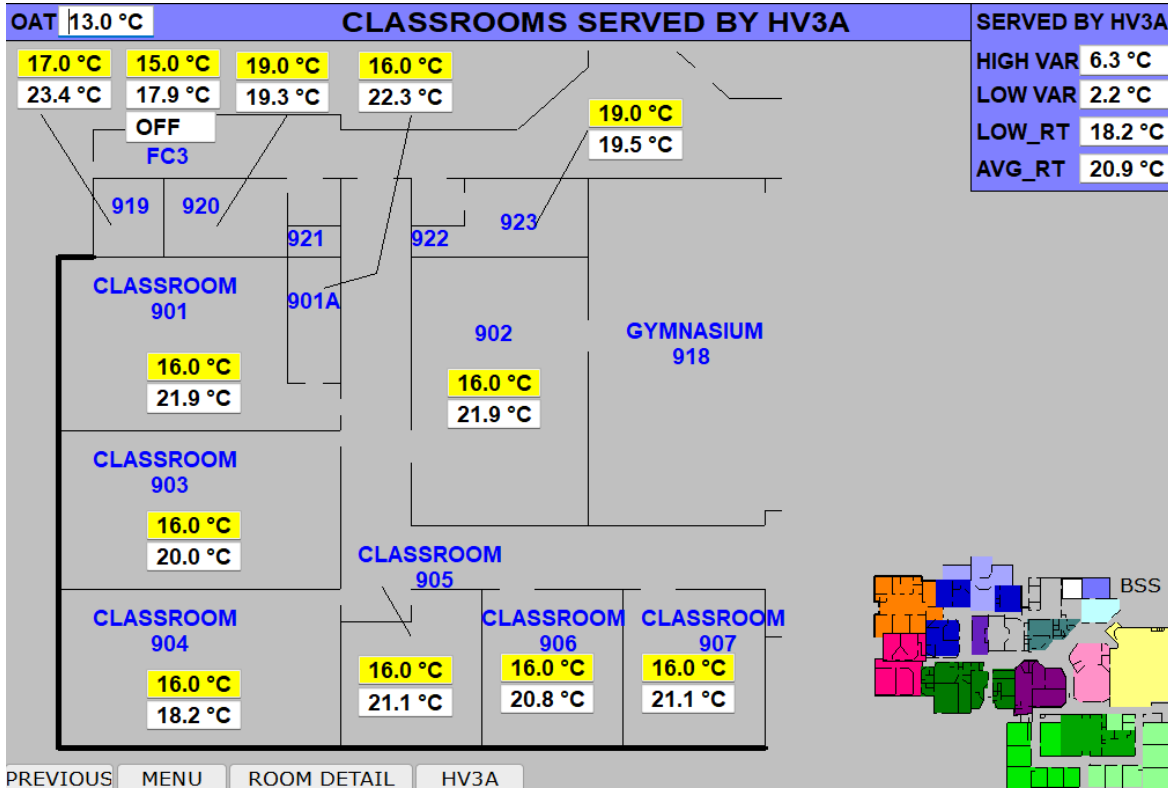

**AHU4**

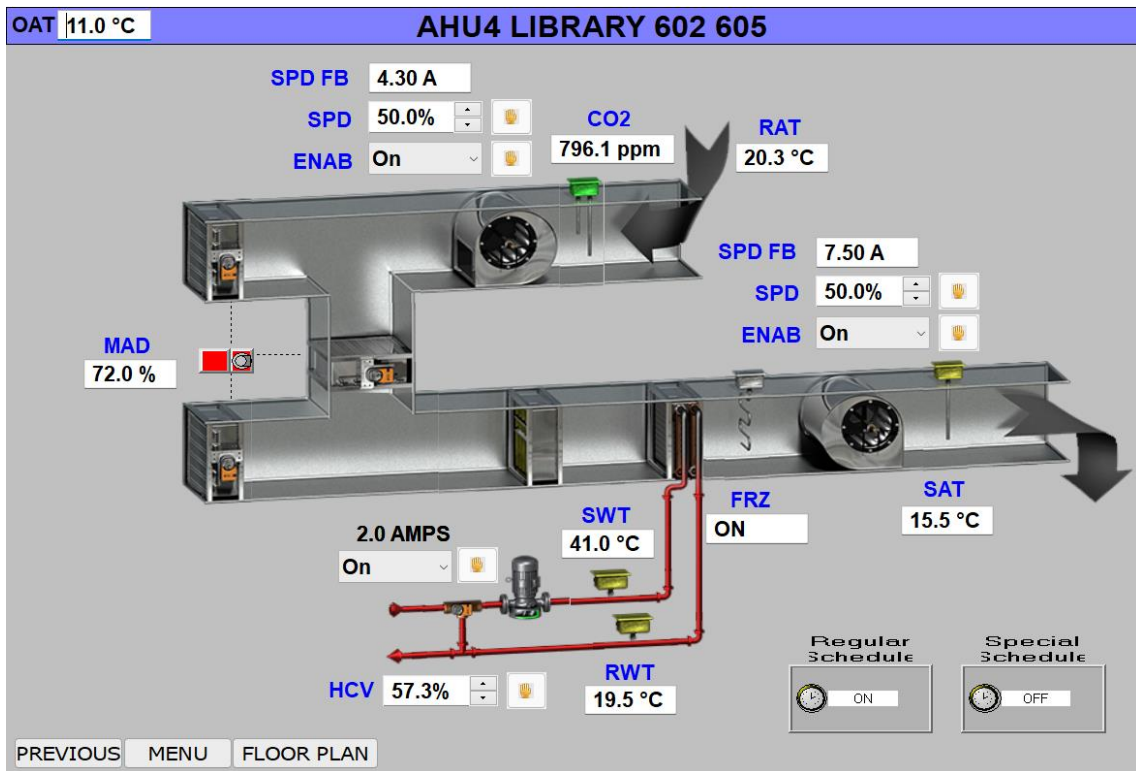

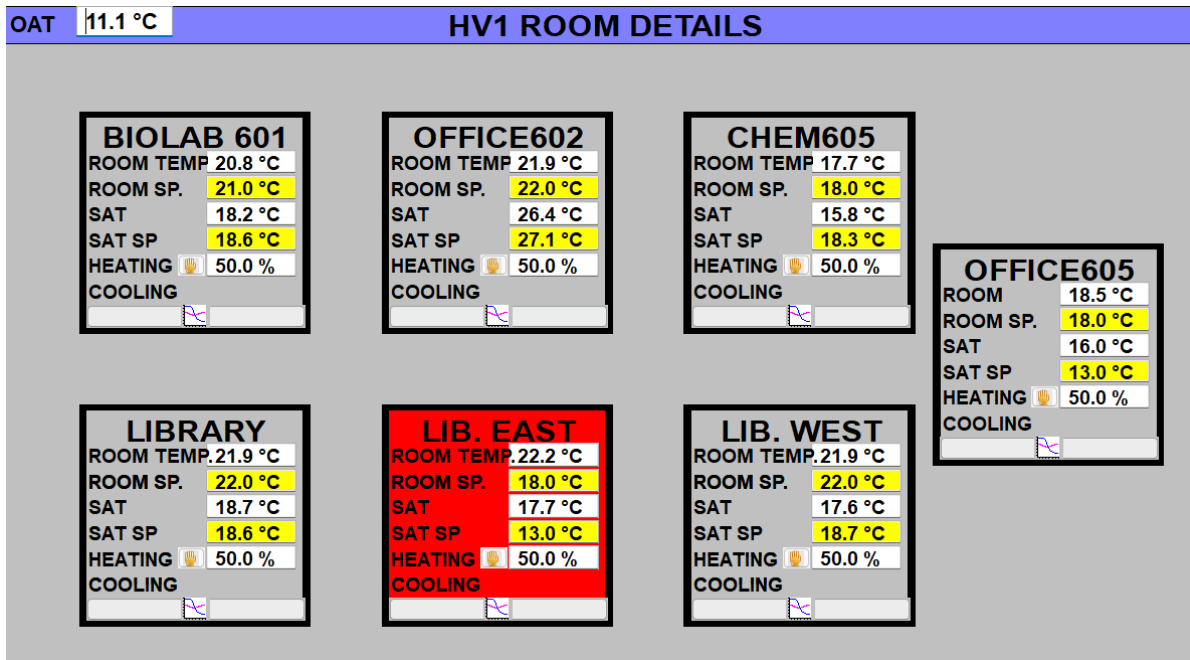
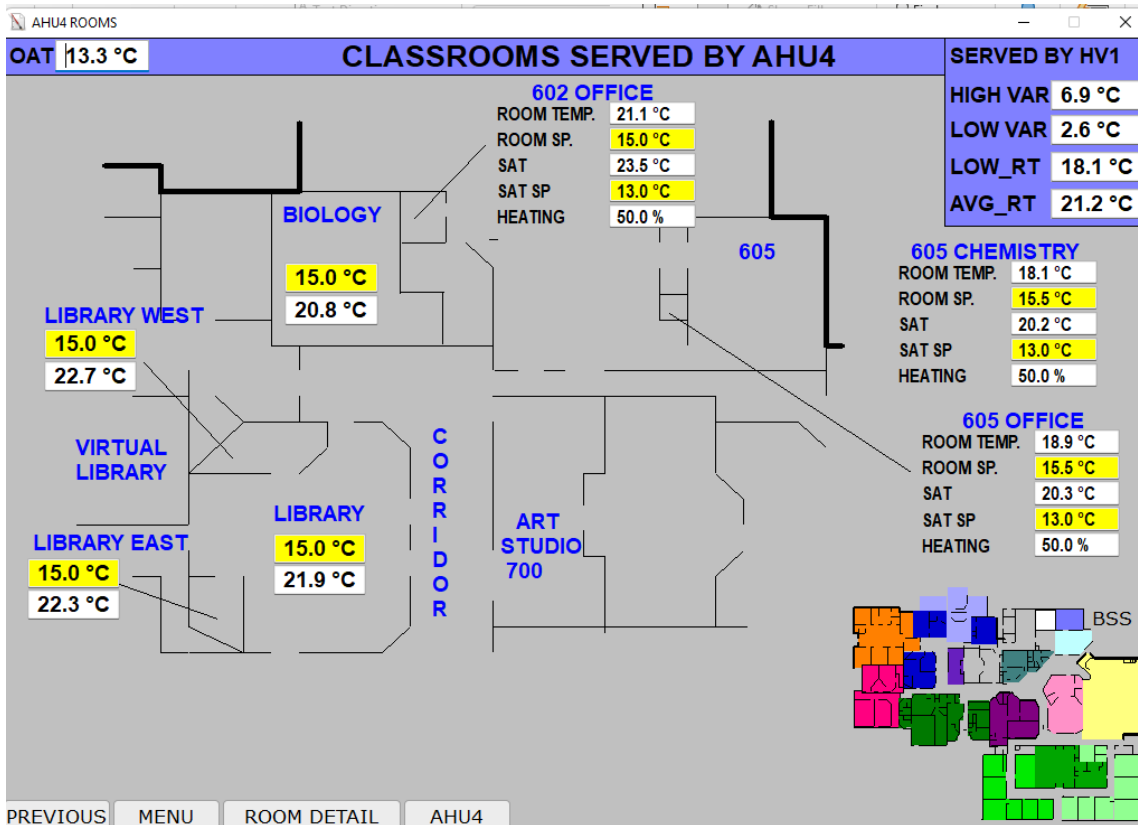
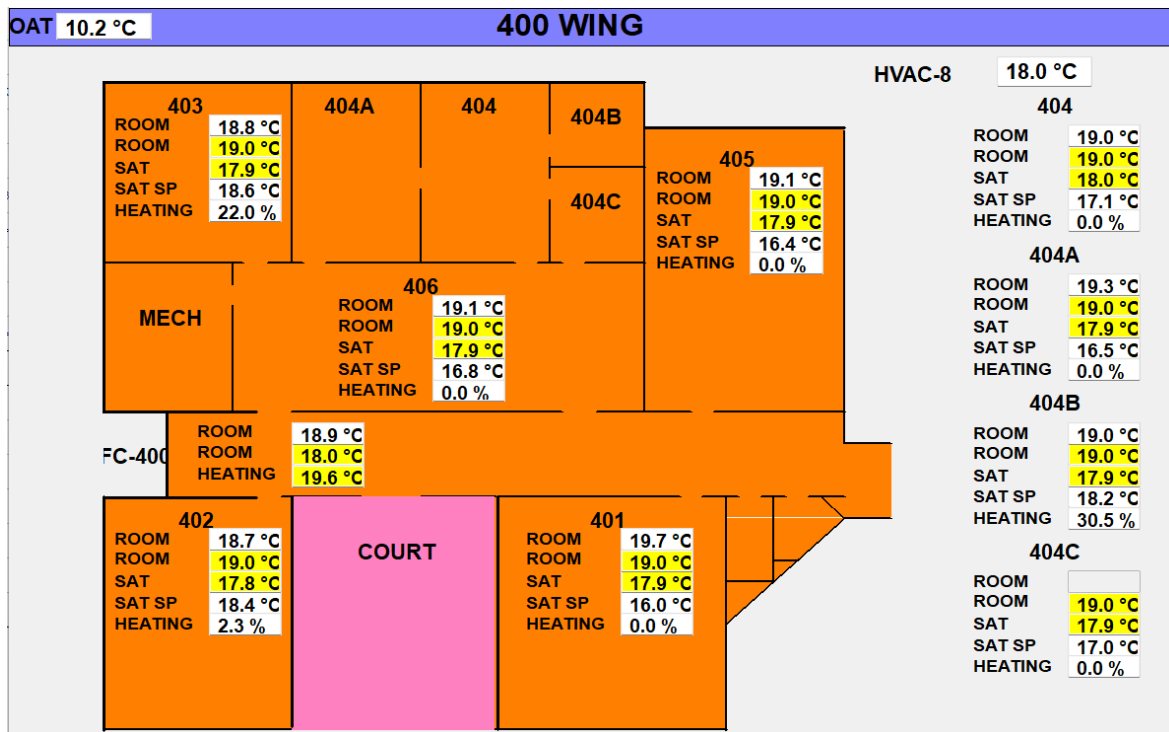
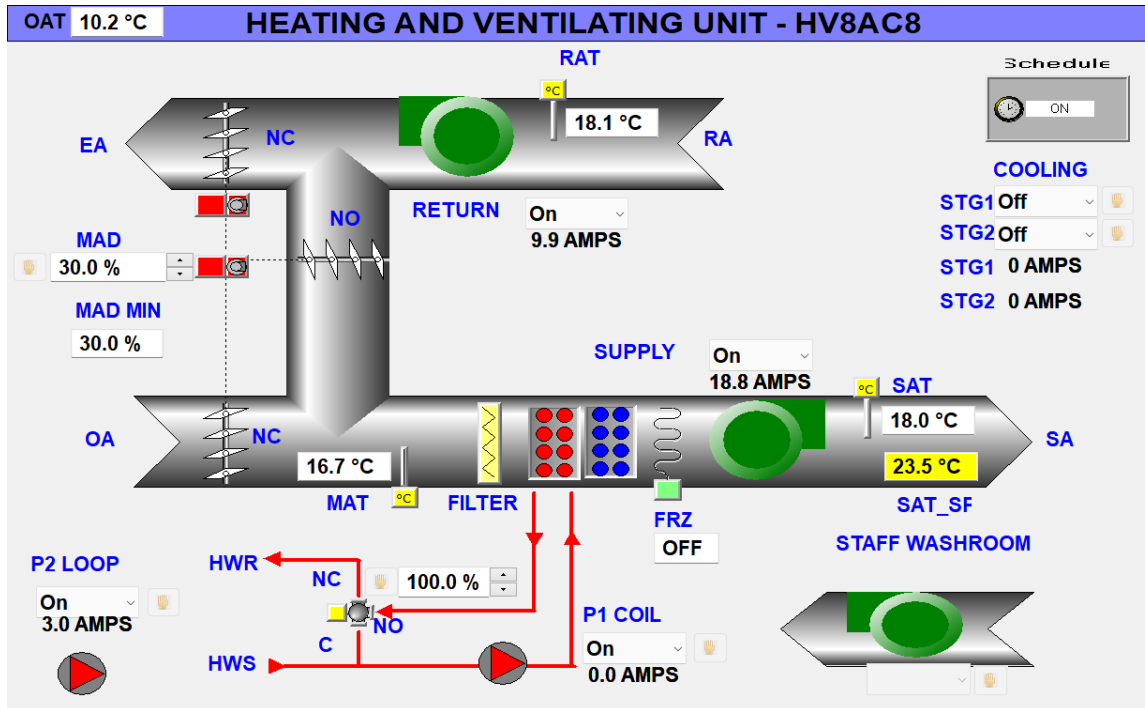
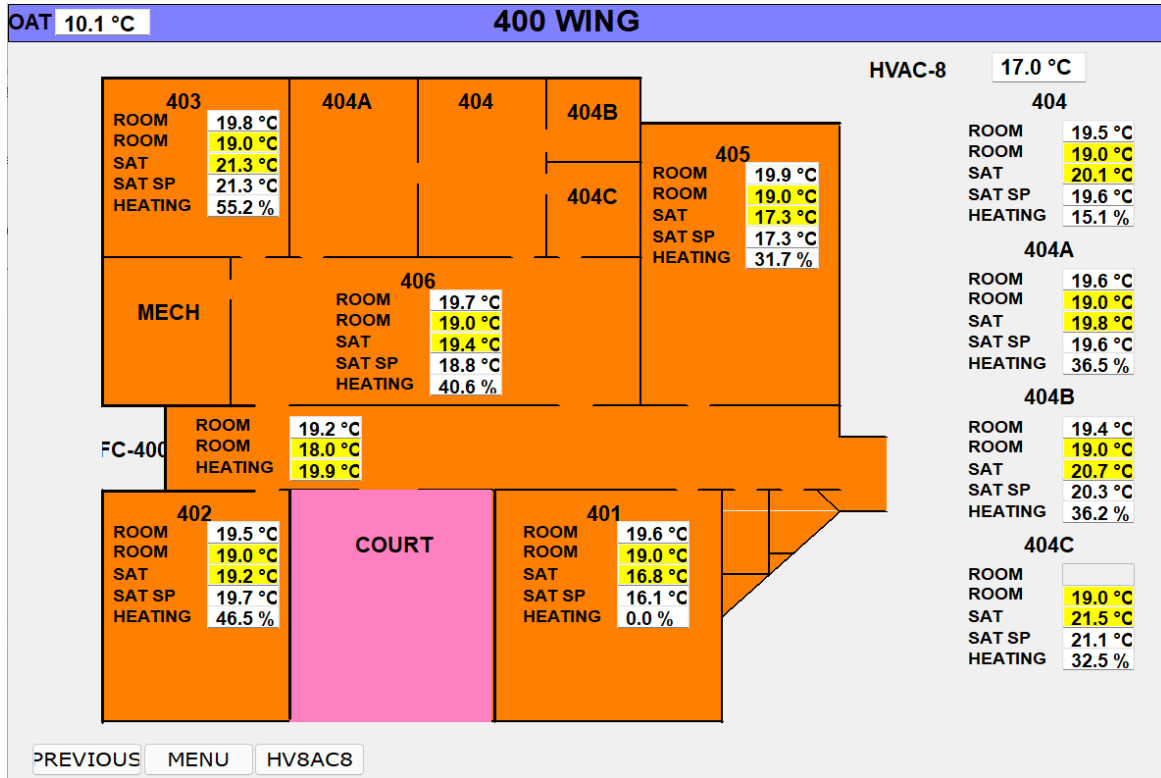

Figure 32: AHU4 room details (note the title is wrong)



**HV8AC8**





**HV10**

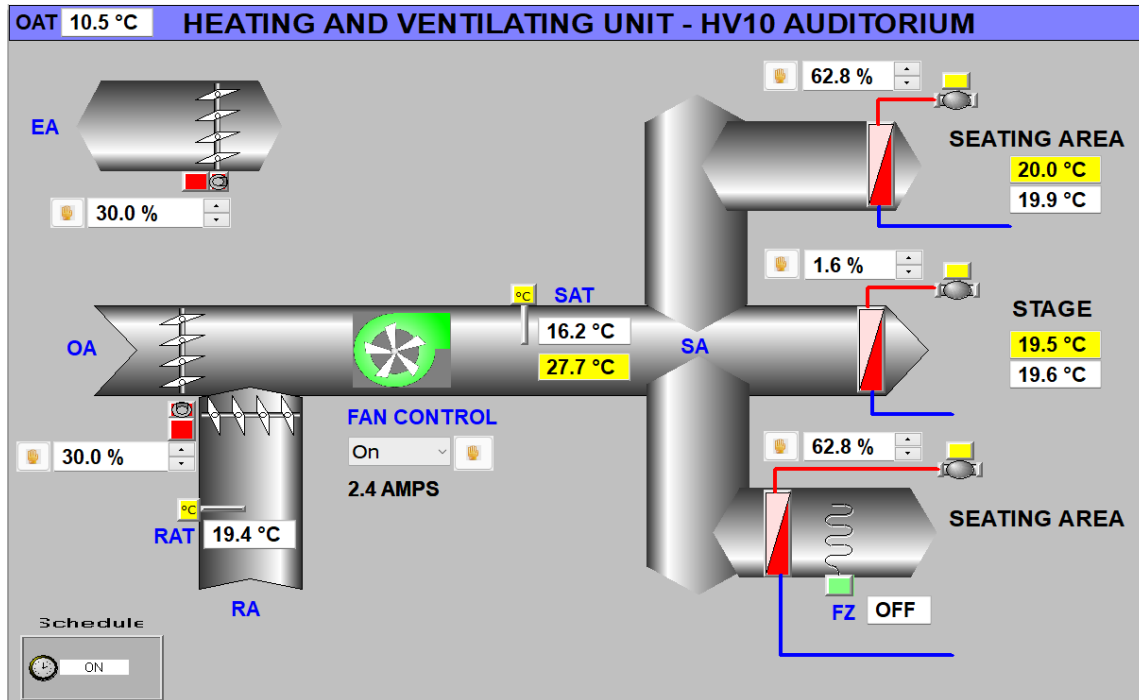

**HV11A**

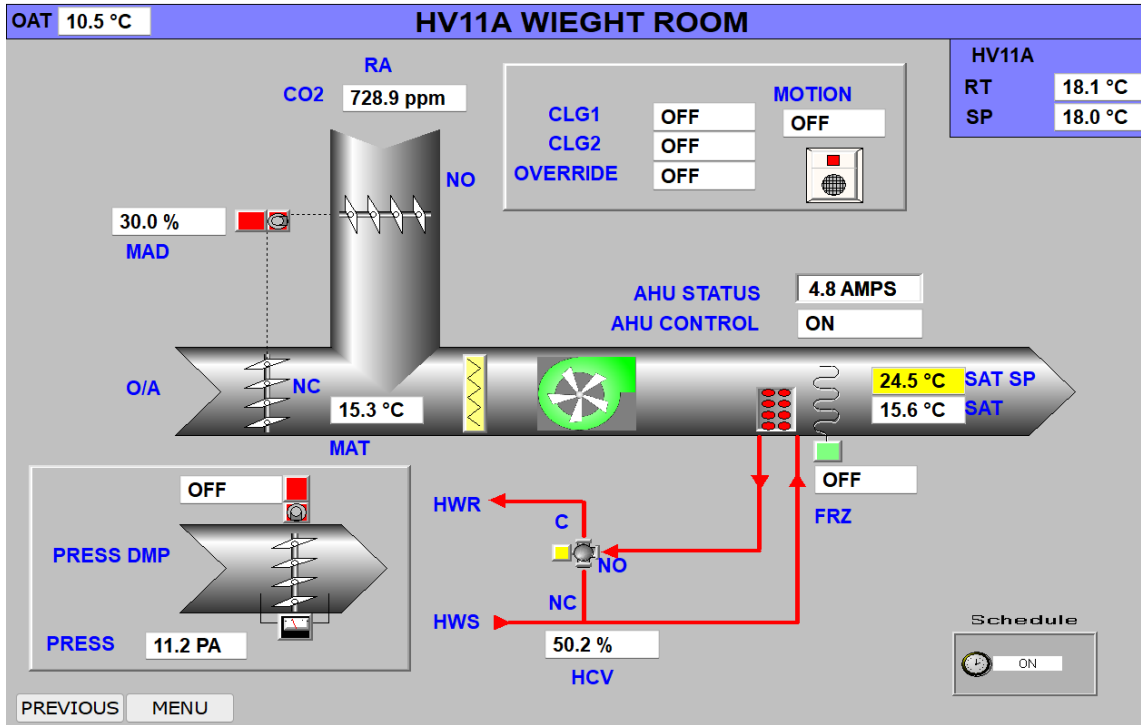

**HV13**

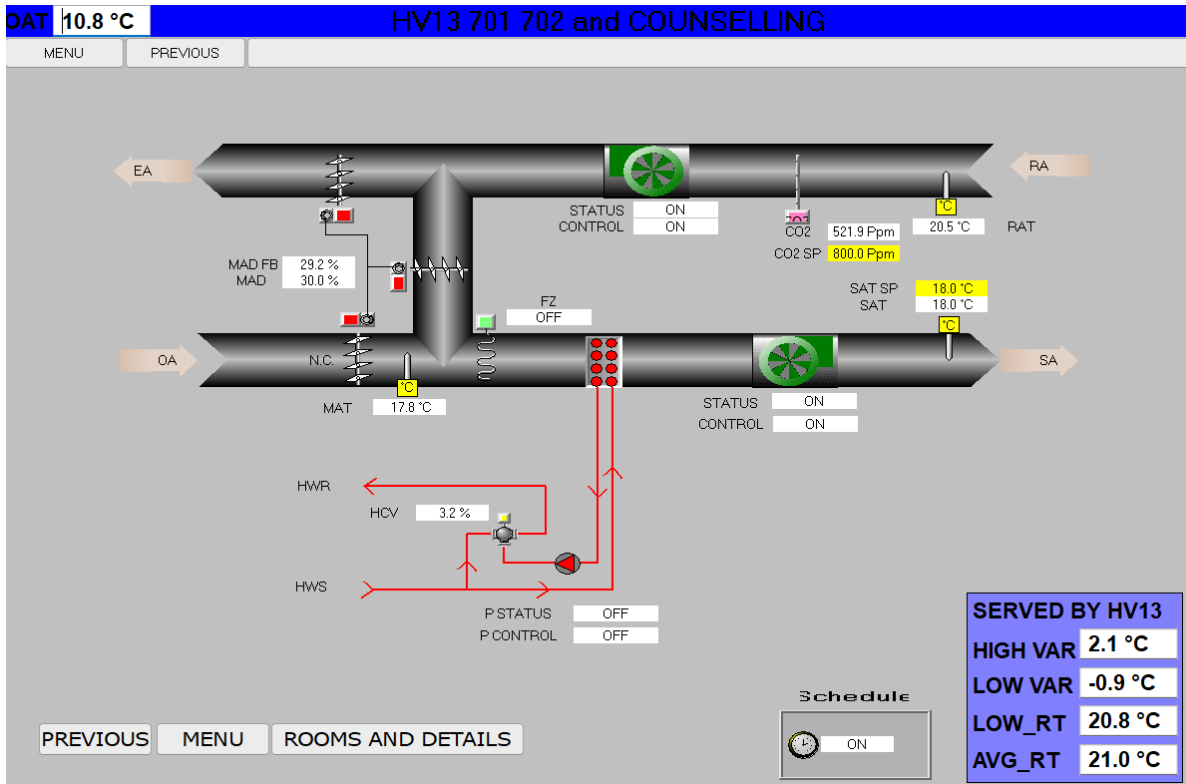



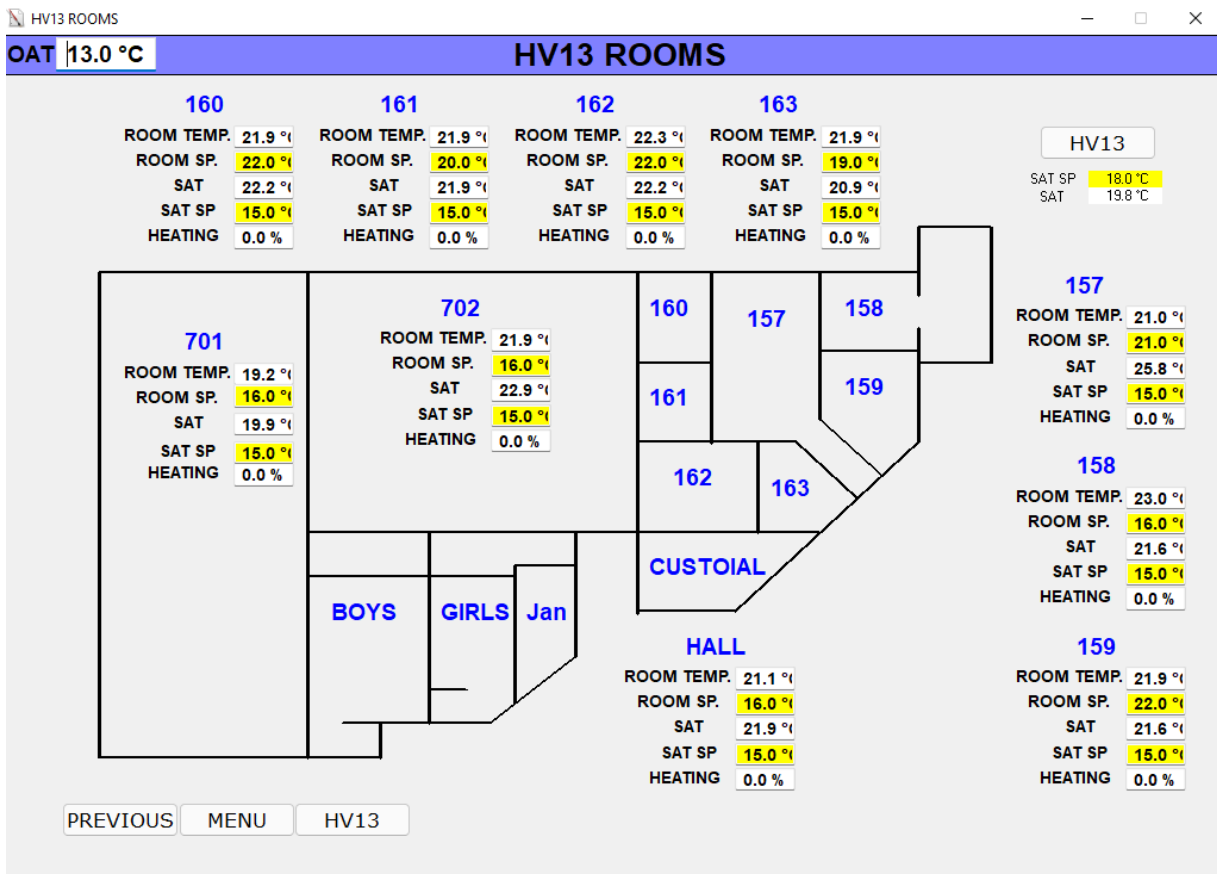
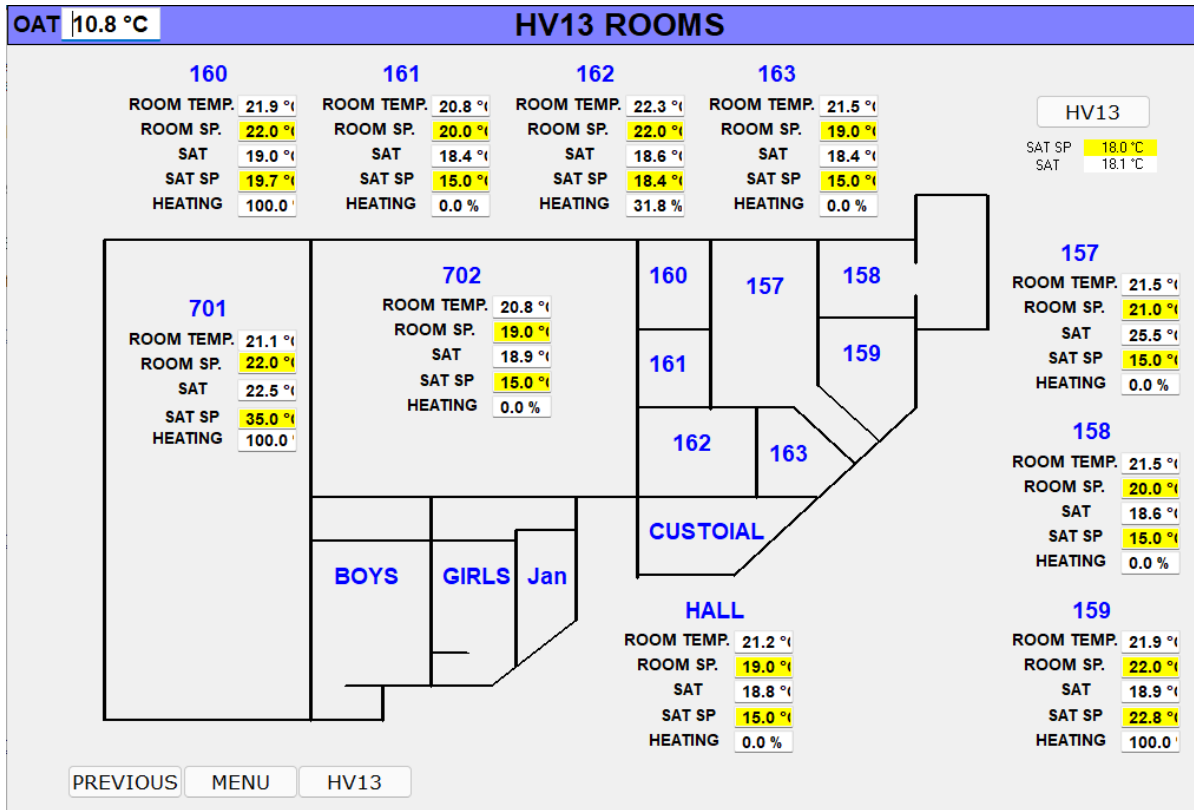

**HV14**

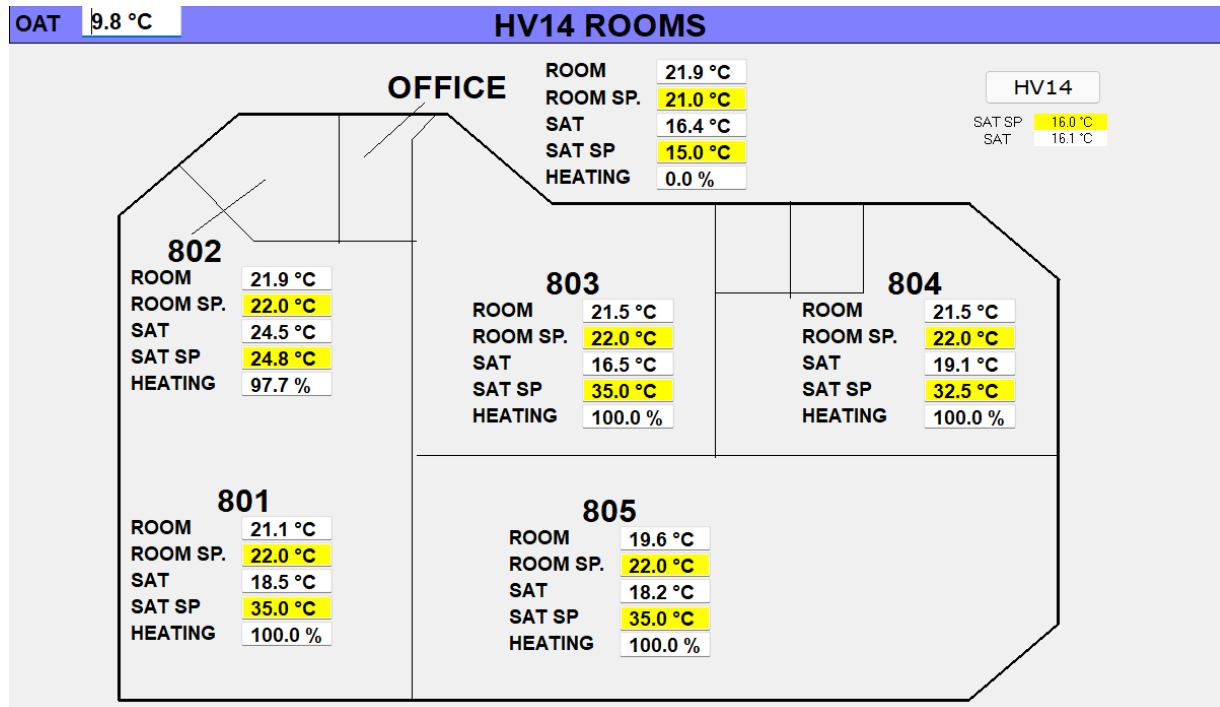
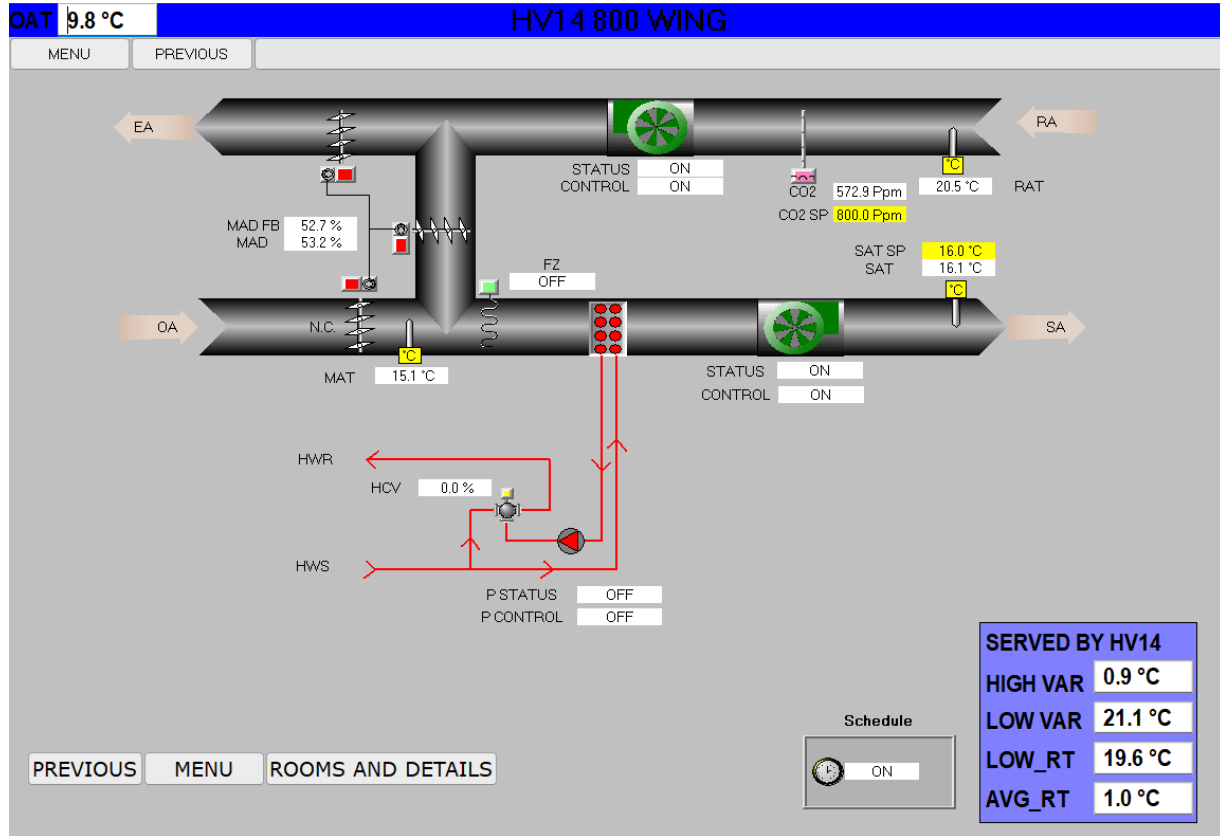

### Boilers (unoccupied)

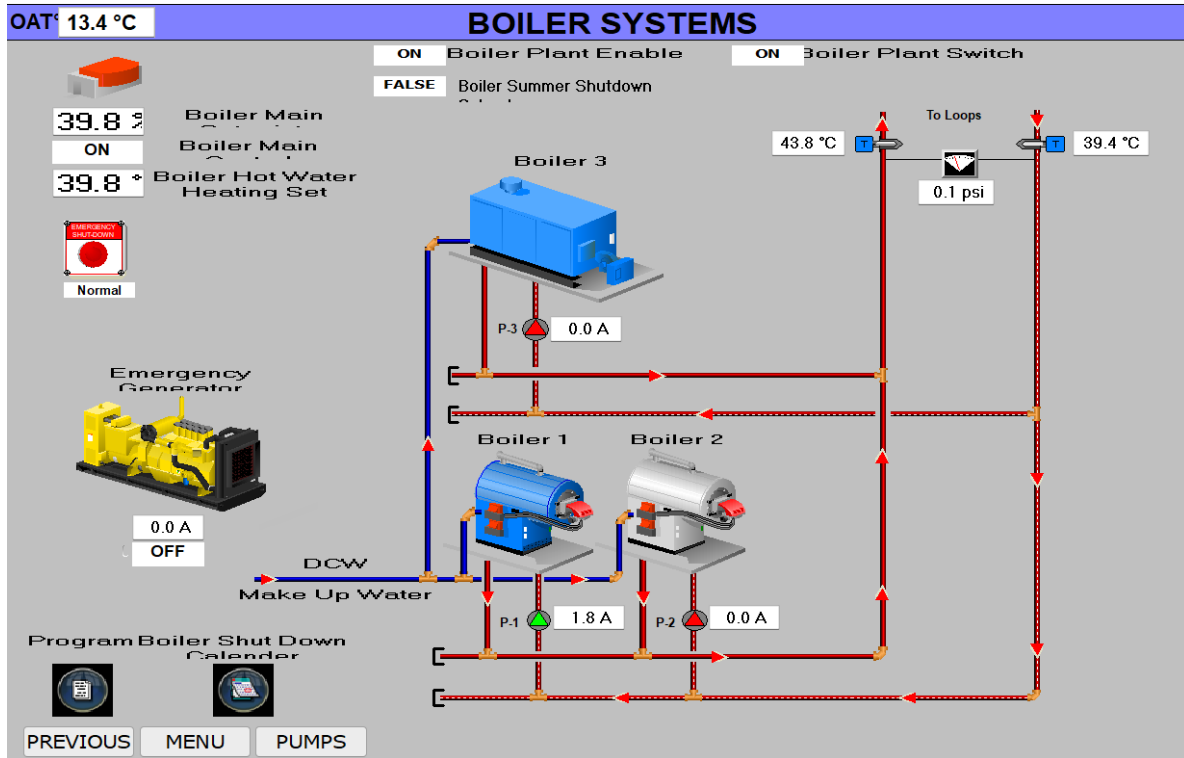

Figure 33: Boiler loop losing over 4°C even with all AHUs off

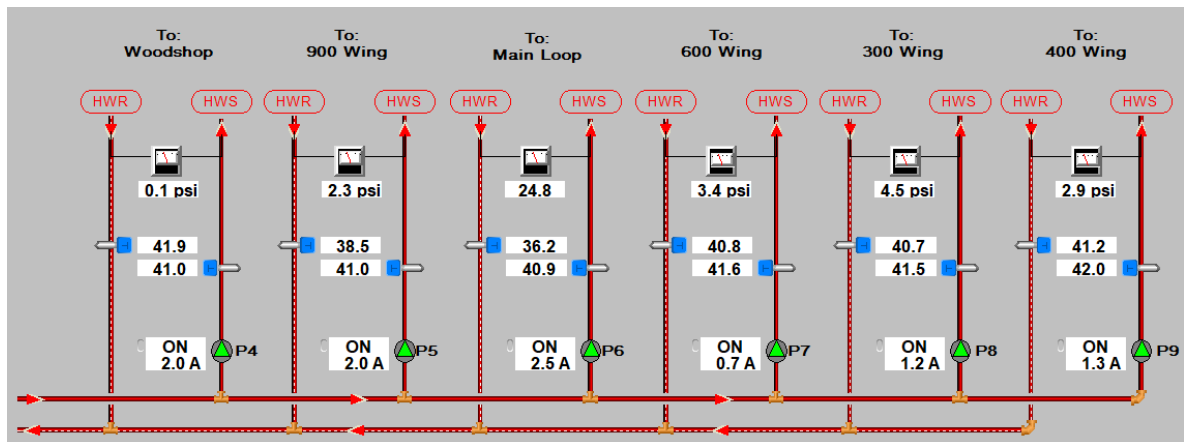

Figure 34: Biggest temperature drop is in the main loop

Continuous Optimization for Commercial Buildings Program

# Recommissioning Report

---

Version	Updated on	Phase
1	12 July, 2022	Investigation phase. Draft for client review.

Prepared for:

School District 69

Kwalikum Secondary School

266 Village Way

Qualicum Beach, BC

Project: BCH-07831

Prism Project: 2021300

---

Prepared by:

Prism Engineering Ltd.

#320 - 3605 Gilmore Way

Burnaby, BC



# TABLE OF CONTENTS

<b>1.0</b>	<b>INTRODUCTION</b> .....	<b>3</b>
<b>2.0</b>	<b>PROJECT OVERVIEW</b> .....	<b>4</b>
<b>3.0</b>	<b>SAVINGS SUMMARY</b> .....	<b>5</b>
<b>4.0</b>	<b>BRIEF DESCRIPTION OF EXISTING SYSTEM</b> .....	<b>6</b>
4.1	FACILITY DESCRIPTION.....	6
4.2	HEATING SYSTEM.....	6
4.3	COOLING SYSTEM.....	8
4.4	VENTILATION SYSTEM.....	8
4.5	DOMESTIC HOT WATER SYSTEM.....	11
4.6	CONTROLS SYSTEM (INCLUDES LIGHTING CONTROLS IF APPLICABLE).....	11
4.7	OTHERS.....	11
<b>5.0</b>	<b>MEASURES SELECTED FOR IMPLEMENTATION (UNDER C.OP. PROGRAM)</b> .....	<b>12</b>
5.1	MEASURE 1: AIR HANDLER HEATING CONTROL VALVES PASSING.....	12
5.2	MEASURE 2: BOILER SETPOINT OPTIMIZATION.....	16
5.3	MEASURE 3: AHUS RUNNING OVERNIGHT.....	17
5.4	MEASURE 4: WEEKLY SCHEDULE.....	18
5.5	MEASURE 5: NIGHT SETBACK.....	20
5.6	MEASURE 6: REHEAT COILS PASSING OR BLOCKED.....	21
5.7	MEASURE 7: HV-7 AND HV-8 OUTDOOR DAMPERS.....	23
5.8	MEASURE 8: BROKEN SENSORS.....	24
<b>6.0</b>	<b>MEASURES TO BE CONSIDERED FOR FUTURE IMPLEMENTATION</b> .....	<b>26</b>
6.1	MEASURE 9: FOUR DUAL-FUEL ROOF TOP UNITS.....	26
6.2	MEASURE 10: CENTRAL AIR SOURCE HEAT PUMP.....	26
<b>7.0</b>	<b>NEXT STEPS – IMPLEMENTATION PHASE AND COMPLETION PHASE</b> .....	<b>27</b>
7.1	IMPLEMENTATION PHASE.....	27
7.2	COMPLETION PHASE.....	27
<b>APPENDIX A:</b>	<b> INVESTIGATION PHASE SUMMARY TABLE</b> .....	<b>29</b>
<b>APPENDIX B:</b>	<b> COMPLETION PHASE SUMMARY TABLE</b> .....	<b>30</b>
<b>APPENDIX C:</b>	<b> SAMPLE TRAINING OUTLINE</b> .....	<b>31</b>
<b>APPENDIX D:</b>	<b> TRAINING COMPLETION FORM</b> .....	<b>32</b>

## 1.0 Introduction

Prism Engineering is pleased to present the results of the Investigation Phase that was conducted as part of BC Hydro's Continuous Optimization for Commercial Buildings Program for Kwalikum Secondary School. The objective of an Investigation is to identify deficiencies and improvements in the operation of a facility's mechanical equipment, lighting, and related controls, and determine opportunities for corrective action that reduce energy consumption and preserve the indoor environmental quality.

This document is a complete record of the work performed at this facility, including the in-depth investigation of the building systems and the implementation of selected measures to optimize building performance.

The Recommissioning Investigation Report provides an overview of the recommendations for the implementation of measures. This information is not considered a specification or detailed sequence of operations. The intent is to provide an overview of the recommendation that can be built upon during the implementation phase as part of any detailed design that may be required. Certain measures may require further investigation and specification for the correct implementation by the owner or the DDC contractor.

Eight recommended retrofits were identified as a part of this investigation. The proposed measures will be reviewed in a meeting with SD69 and Prism Engineering representatives to determine which measures will be implemented.

Recommended retrofits for implementation include:

- Measure #1: Air handler heating control valves passing
- Measure #2: Boiler setpoint optimization
- Measure #3: AHUs running overnight
- Measure #4: Weekly schedule
- Measure #5: Night Setback
- Measure #6: Reheat coils passing or blocked
- Measure #7: HV-7 and HV-8 Outdoor Dampers
- Measure #8: Broken sensors

These measures are presented in the Investigation Summary Table (see Appendix A).

While the investigation focuses on low-cost improvements with short paybacks, some capital improvement opportunities may also be identified. Major retrofit measures are beyond the scope of this program, but other BC Hydro and FortisBC programs provide a variety of incentives to complete the retrofits. Retrofits were identified as a part of this investigation that could potentially qualify for other BC Hydro and FortisBC programs, these measures are described in Section 6.

Retrofits include:

- Measure #9: Four ASHP Hot Water RTUs
- Measure #10: Central Air Source Heat Pump



## 2.0 Project Overview

Project Information		Complete cells this background colour	
RCx Project File #	BCH-07831		
Date of Workbook Update	12-Jul-2022		
Organization	School District 69		
Building Name	Kwalikum Secondary School		
Building Type	Large School		
Location (City)	Qualicum Beach, BC		
Owner Contact	Phil Munro		
Investigation Phase start date	01-Feb-2022		
Participated in previous BCH RCx program?	No		
Previous RCx File #			
Previous RCx completion date			
Building Information			
Facility Area (ft <sup>2</sup> )	105,206		
Annual elec consumption (kWh)	676,432	6.4	kWh/ft <sup>2</sup>
Annual elec costs (\$)	\$ 66,547	\$ 0.10	Avg. \$/kWh
Fuel type	Natural Gas		
Annual fuel consumption (GJ)	6,866	18.1	ekWh/ft <sup>2</sup>
Annual fuel cost (\$)	\$ 83,237	\$ 12.1	Avg. \$/GJ
Total GHG emissions (tCO <sub>2</sub> e/yr)	350		
Total Energy Cost	\$ 149,784	\$ 1.42	\$/ft <sup>2</sup>
Energy Use Intensity (ekWh/ft <sup>2</sup> )	24.6		
Year for energy data above	2021		



### 3.0 Savings Summary

Savings Summary	Previous, still working	New + Previous, rectify + Previous, documented					
		Identified		Selected		Implemented	
	# of measures	10		8		8	
		Re-claim Savings	Total Savings	% Savings	Total Savings	% Savings	Total Savings
Electrical savings (kWh/yr)	-	76,672	11.3%	194,307	28.7%	194,307	28.7%
Fuel savings (GJ/yr)	-	4,779	69.6%	3,407	49.6%	3,407	49.6%
Cost savings (\$)	\$ -	\$ 65,480	43.7%	\$ 60,420	40.3%	\$ 60,420	40.3%
GHG reduction (tCO2e/yr)	-	239.2	68.4%	172.0	49.2%	172.0	49.2%
<b># of Abandoned measures</b>	<b>0</b>						



## 4.0 Brief Description of Existing System

This section contains a brief description of the existing HVAC and Controls system. The information is intended to provide a general overview only.

### 4.1 Facility Description

Kwalikum Secondary School consists of two buildings. The original two-storey South Block was built in 1981 and expanded around 1987, with a major retrofit of HVAC systems in 2002. The South Block contains classrooms, workshops, and gym. The two-storey North Block was built in 2002 and contains classrooms and admin offices. The total area of the school is 105,207 sqft.

### 4.2 Heating System

A boiler plant with eight IBC 399 MBH condensing boilers (Figure 1 and Figure 2) is the main source of heating to both blocks. The primary loop is connected through a low loss header to secondary loops serving heating coils in air handlers, reheat coils, convective heaters and fan coils in entrance ways, radiant panel, and unit heaters. Distribution loops and pumps are shown in Figure 3 and Table 1.



Figure 1: Four of the IBC boilers

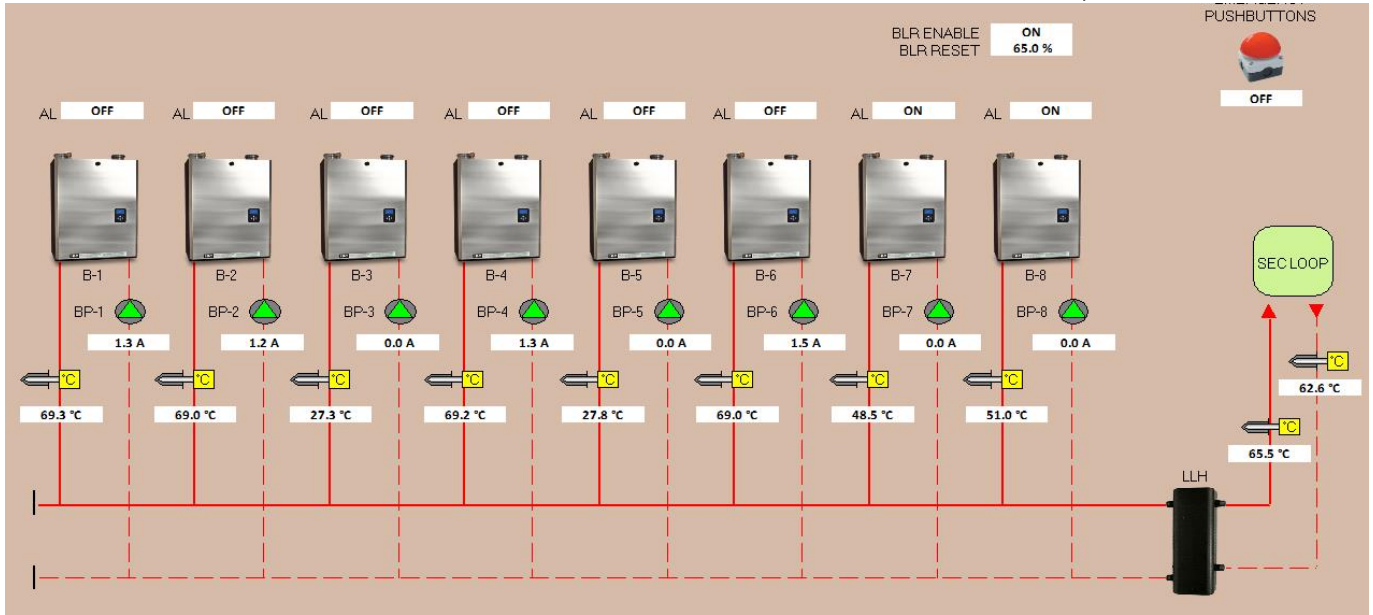

Figure 2: Boiler Plant DDC Graphic

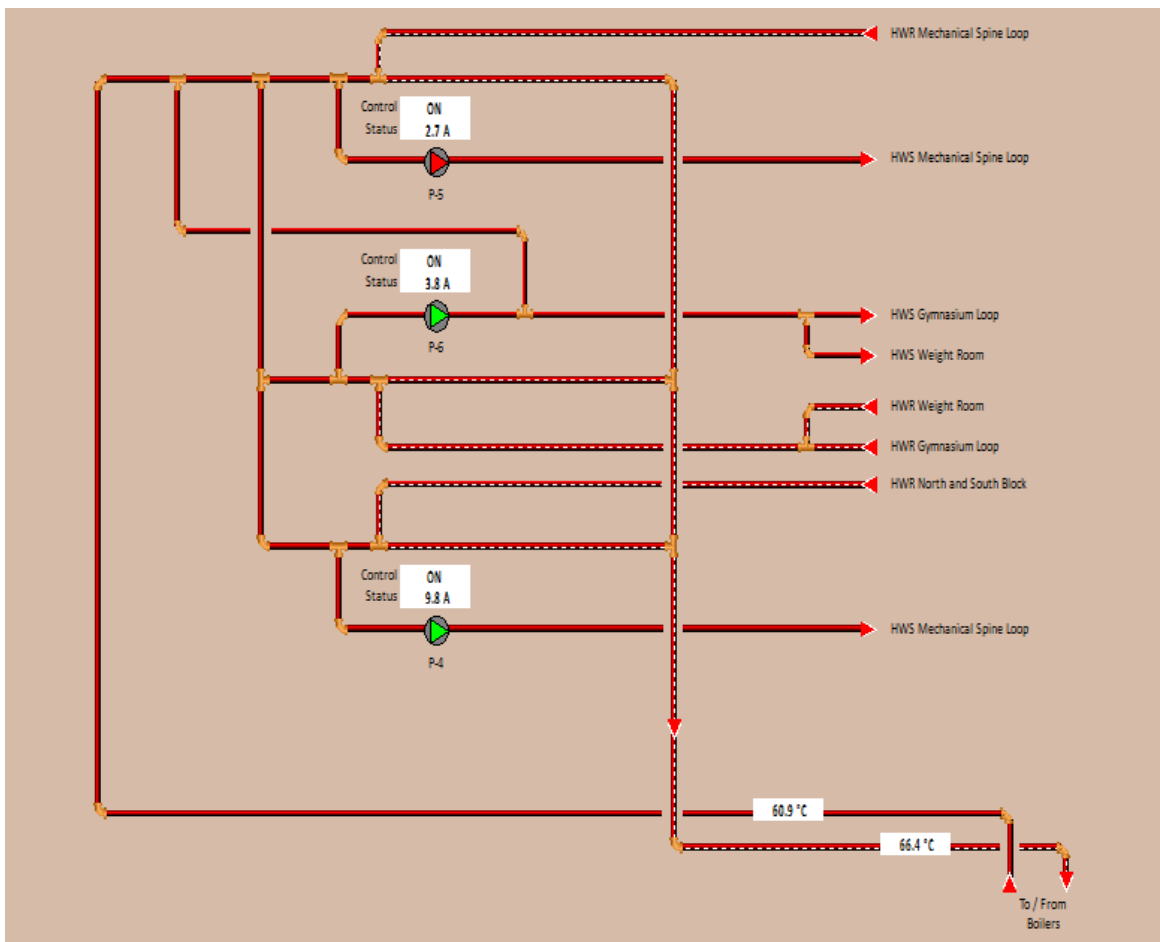

Figure 3: Secondary heating water loops



Table 1: Heating Water Pumps

Tag	Serves	Size	Flow (GPM)	Head (Ft)
P-3	DWH recirc (South)	179 W	Unknown	Unknown
P4	Mech Spine Secondary loop	5 HP	220.8	51
P-5	Mech Spine, A Secondary loop	1.5 HP	90.6	33
P-6	Gym/Weights Secondary loop	1 HP	82.3	30
P-7	North Block Loop (not shown in DDC)	2 HP	112.4	39
P-8	AC-4 Coils	1/3 HP	38	30
P-9	DHW recirc (South)	1/25 HP	Unknown	Unknown
BP-1 to BP-8	Boilers Primary Circulation	189W each	Unknown	Unknown

### 4.3 Cooling System

Cooling is provided by DX coils and condensing units in AC-1 to AC-5.

### 4.4 Ventilation System

There are five rooftop units on the North Block, and 7 rooftop units and an indoor air handler (AC-4) on the South Block, all listed in Table 2.

Table 2: Air handling units

Tag	Service	Supply Flow	Supply Fan	Return Fan	Heating Coil	Cooling Coil	Mix/OA
North Block (2002)							
AC-1	Technology Class and Workroom	3,440 CFM	5 HP	2 HP	Hydronic	DX 9 Tons	Mix Min 20%
AC-2	Staff Room, Admin, Counseling	4,500 CFM	5 HP	2 HP	Hydronic	DX 11 Tons	Mix Min 10%
HV-1	Music Room and Practice	10,560 CFM	7.5 HP	5 HP	Hydronic	-	Mix

Tag	Service	Supply Flow	Supply Fan	Return Fan	Heating Coil	Cooling Coil	Mix/OA
							Min 20%
HV-2	North Block Ground and Upper Classrooms	17,065 CFM	10HP	7.5HP	Hydronic	-	Mix Min 20%
HV-3	Multi-purpose Room	12,000 CFM	7.5 HP	5 HP	Hydronic duct reheats	-	Mix Min 20%
<b>South Block (1981/1987)</b>							
AC-3 (2002)	Multimedia Comms and Research	6,435 CFM	7.5 HP	3 HP	Hydronic	DX 18 Tons	Mix Min 20%
AC-4	Admin, Computers Science and Art	20,788 CFM	20 HP	N/A	Hydronic	DX 60 Tons	Mix Min 20%
AC-5 (2002)	South Class: Textiles, Food, Art	7,865 CFM	7.5 HP	3 HP	Hydronic	DX 21 Tons	Mix Min 10%
HV-4 2002	Metal Shop	6,500 CFM	5 HP	N/A	Hydronic	-	Mix Min 20%
HV-5 (2002)	Power and Automotive Shop	6,000 CFM	5 HP	N/A	Hydronic	-	Mix Min 20%
HV-6 (2002)	Wood Shop	7,695 CFM	5 HP	N/A	Hydronic	-	Mix Min 20%
HV-7 (2002)	Admin and Drama	7,300 CFM	5 HP	5 HP	Hydronic	-	Mix Min 20%
HV-8 (2002)	Gym and Change Rooms	42,035 CFM	25 HP VSD	15 HP VSD	Hydronic	-	Mix Min 20%

The two buildings have approximately 30 exhaust fans.

Table 3: Exhaust fans

Tag	Service	Airflow	Fan	Control
EF-1	Washroom. Ground Floor	312 l/s	1/4 HP	DDC / HV-2
EF-2	Staff Washrooms	94 l/s	100 W	DDC / AC-2
EF-3	Staff Room	283 l/	1/4 HP	DDC / AC-2
EF-4	Office N108	154 l/s	Unknown	DDC / AC-2
EF-5	Home Economics N121	1312 l/s	1/2 HP	DDC
EF-6	Storage N131	195 l/s	1/10 HP	-
EF-7	Elevator Mech Room N217	200 l/s	1/10 HP	Thermostat
EF-8	Fume Hood	378 l/s	1/4 HP	Manual
EF-9	Fume Hood	1034 l/s	1/4 HP	Manual
EF-10	Fume Hood	378 l/s	1/4 HP	Manual
EF-11	Fume Hood	378 l/s	1/4 HP	Manual
EF-12	Science 256	800 l/s	1/4 HP	DDC / AC-4
EF-13	Science 258	900 l/s	1/4 HP	DDC / AC-4
EF-14	Physics 202	900 l/s	1/4 HP	DDC / AC-4
EF-15	Biology 264	900 l/s	1/4 HP	DDC / AC-4
Ef-16	Chemistry 201	Unknown	Unknown	DDC / AC-4
EF-17	Washroom, Ground Floor	Unknown	Unknown	DDC / AC-4
EF-18	Welding Hood	1228 l/s	5 HP	Manual
EF-19	Heat Treatment 241	236 l/s	1/4 HP	Thermostat.
EF-20	Finish Room 232	455 l/s	1/3 HP	Switch (light)
EF-21	Foods 255	Unknown	Unknown	DDC / AC-5
EF-23E	Change Room	1025 l/s	1/3 HP	DDC / HV-8
EF-24	Gym Storage 144	Unknown	Unknown	DDC / HV-8
EF-25	Weight Room 145	566 l/s	1/3 HP	Manual
EF-26	Storage 124	71 l/s	161 W	DDC
EF-27	Rooms W246 W247	457 l/s	1/3 HP	DDC / AC-5
EF-28	Medical Room N106	154 l/s	100 W	Manual
EF-29	Elevator Machine Room	94 l/s	100 W	-
EF-30	N142A	306 l/s	Unknown	-
EF-31	Electrical 108	958 l/s	3/4 HP	-

## 4.5 Domestic Hot Water System

Each building has its own domestic hot water (DHW) system, shown in Table 4.

Table 4: Domestic Hot Water

Block	Heaters	Heating capacity	Storage	Recirculation Pump
South Block	Electric DWH heater	12 kW	404 liter	Fractional
North Block	Two atmospheric gas-fired heaters	2 x 400 MBH (input)	2 x 80 US Gal	1/25 HP

## 4.6 Controls System (includes Lighting Controls if Applicable)

The HVAC system is controlled by a Delta Controls DDC system, using ORCAView 3.40 software. Remote access to the system is available. DHW is not on the DDC. Trend data is seldom available for more than a day.

## 4.7 Others

The school has a 40.8 kW solar PV system on the roof of the South Block. It was installed in 2017 and produces approximately 47,000 kWh electricity annually.

## 5.0 Measures Selected for Implementation (Under C.Op. Program)

This section provides an overview of each measure, recommendations for implementation, and update after implementation.

### 5.1 Measure 1: Air Handler Heating Control Valves Passing

#### 5.1.1 Description of Finding

Several air handlers appear to have passing heating coil control valves, based on the rise in temperature between mixed air temperature and supply air temperature, with the heating valve closed. During conditions when the boilers were disabled, the temperature rise was confirmed to be approximately 1°C (or less) which is what is expected from just the fan.

#### HV-2

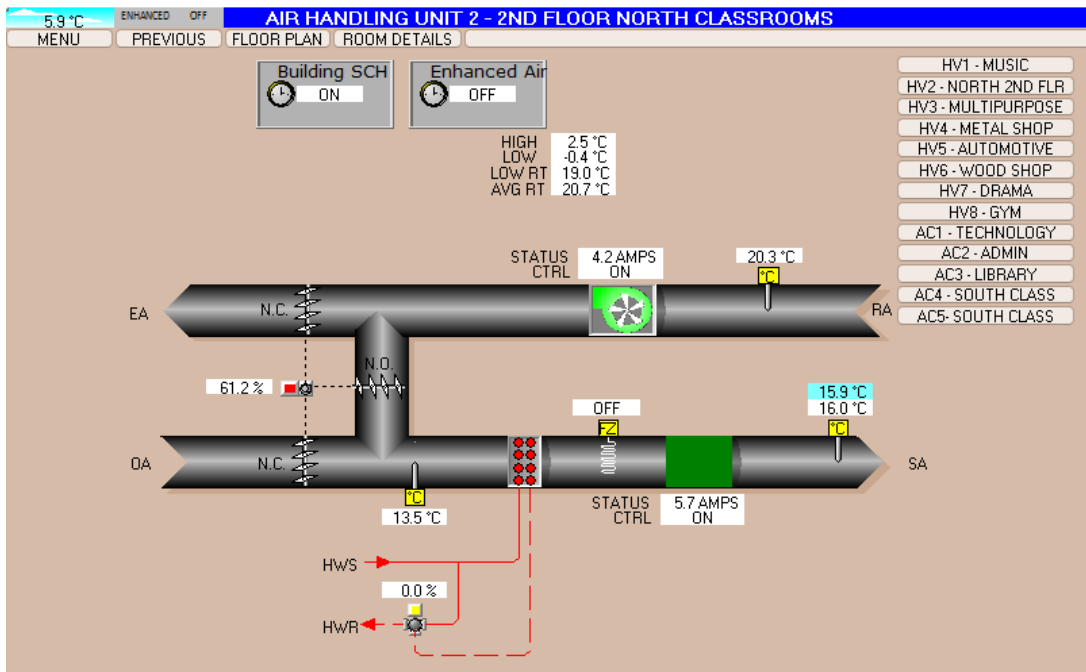

Figure 4: Heat rise across the AHU-2 heating coil is 3.5°C with its control valve closed

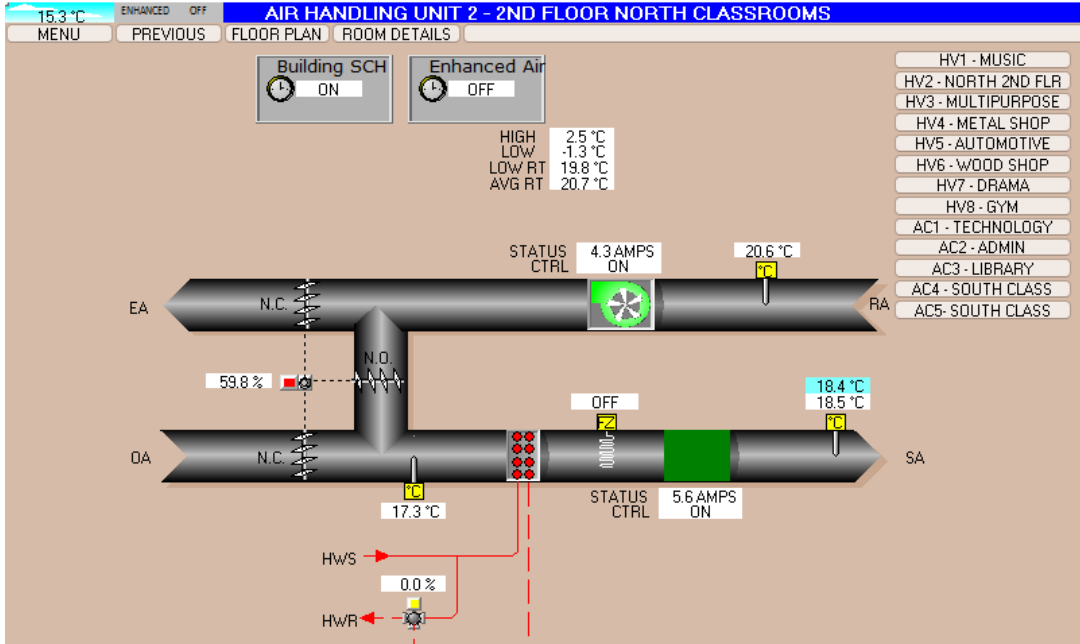

Figure 5: AHU-2 Heat rise across the heating coil drops to 1.2°C when the boilers are disabled and the coil is cold.

### HV-3

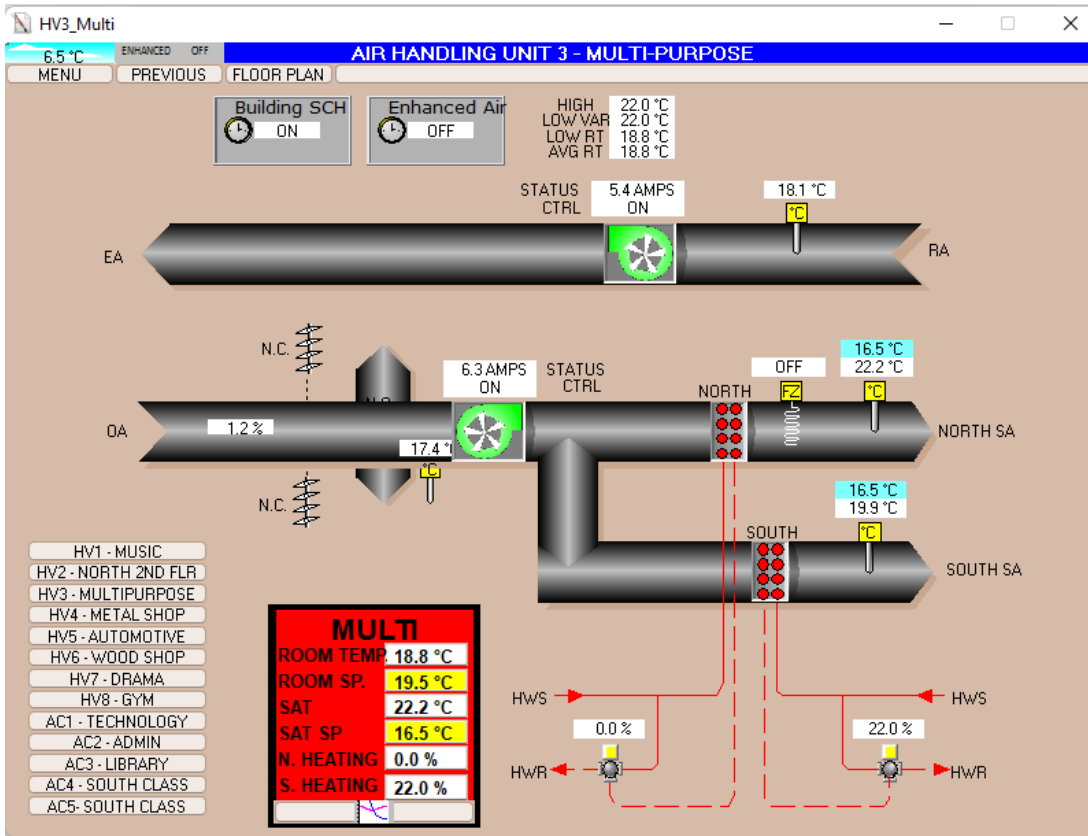

Figure 6: Heat rise of 4.8°C across the AHU-3 north supply air heating coil



**HV-4**

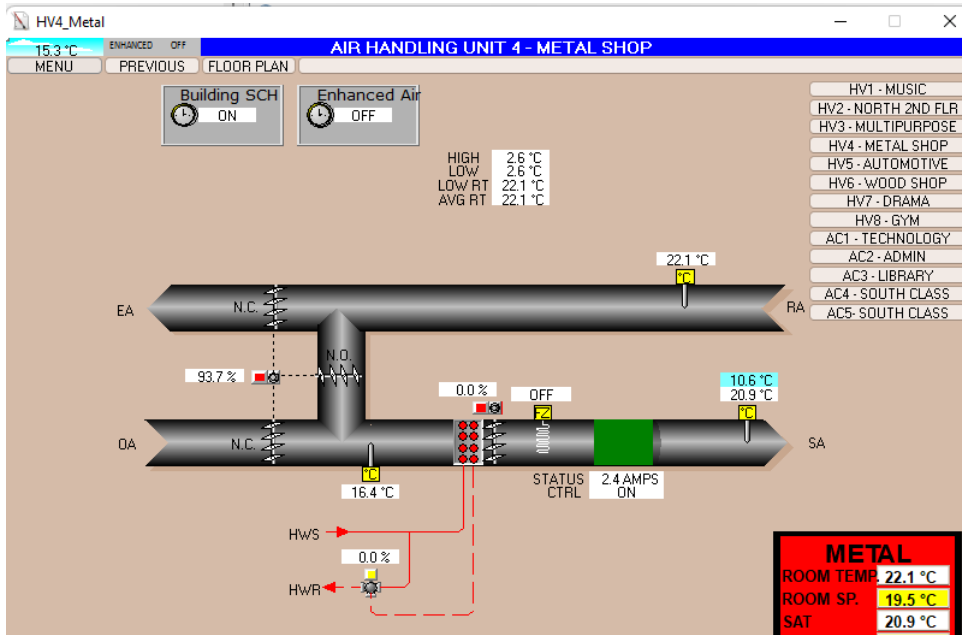

Figure 7: Temperature rise across the heating coil is 4.5°C with the control valve closed.

**HV-6**

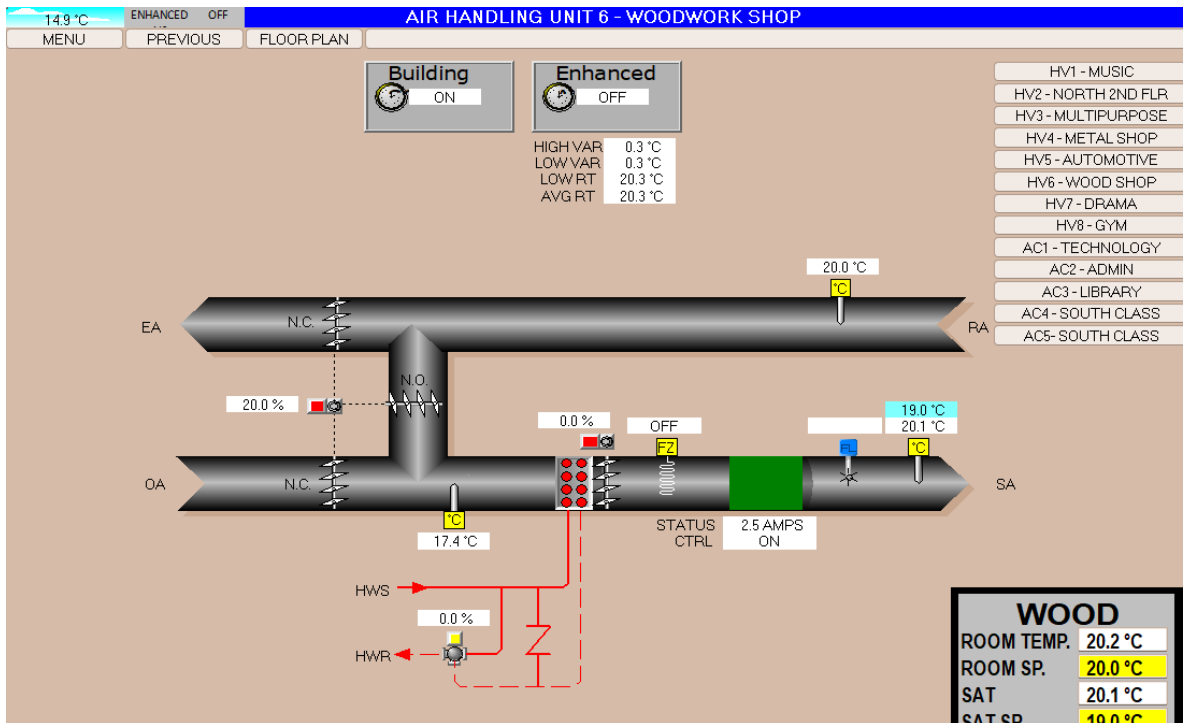

Figure 8: Temperature rise of 2.6°C across the heating coil with the control valve closed.

**HV-8**

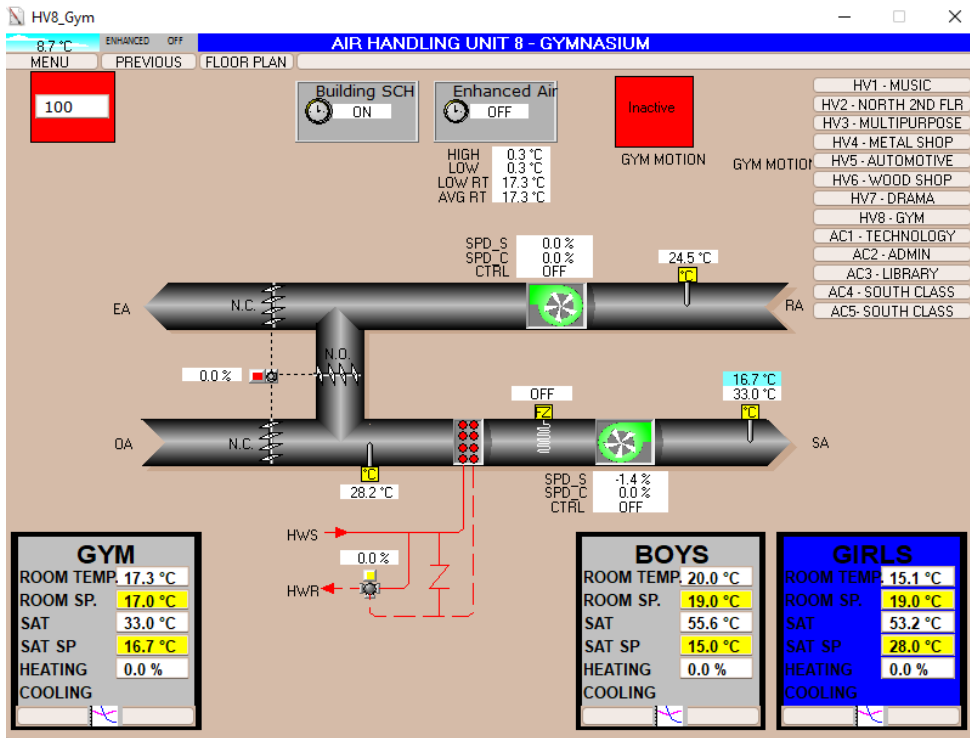

Figure 9: HV8 has a temperature rise of 7.5°C across the heating coil

**AC-2**

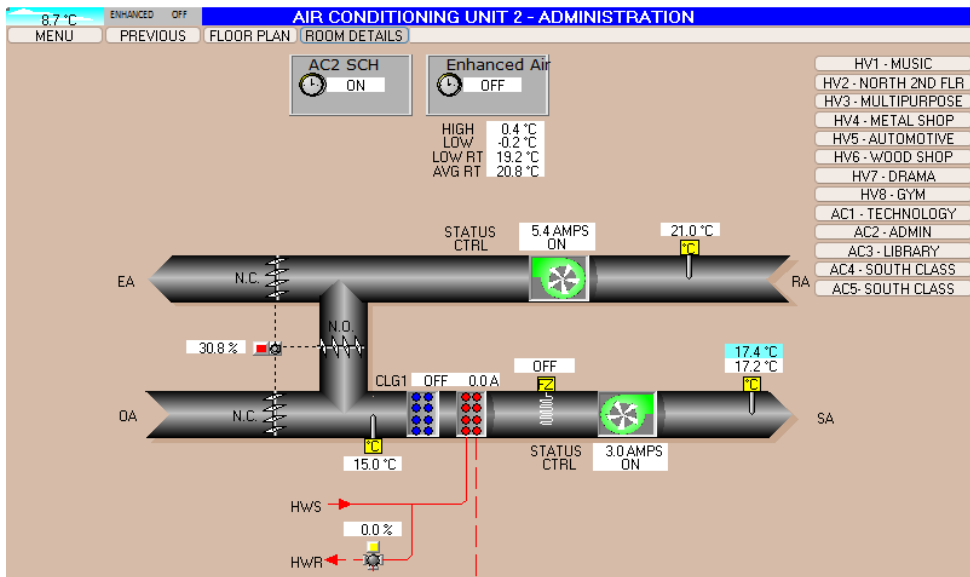

Figure 10: AC-2 showing a rise in air temperature across the heating coil with its control valve closed.



### 5.1.2 Measure Description

Validate heating valve issues with manual temperature readings in the field:

Operate the mentioned air handlers with the supply fan enabled and the heating coil control valve commanded fully closed (0%). Manually measure the air temperature at the coil inlet and outlet. A temperature rise indicates a passing valve. Furthermore, the heating coil inlet and outlet pipes should be cold after the control valve is closed for several minutes. Diagnose the valve issue as required, including replacing the valve, or repairing control parts.

Since this issue has affected multiple units, there may be an issue with heating loop water. Water quality should be tested and water treatment processes should be reviewed.

### 5.1.3 Measure Implementation Update

[Provide confirmation details **AFTER** the measure is implemented and verified]

## 5.2 Measure 2: Boiler Setpoint Optimization

### 5.2.1 Description of Finding

The boiler control program resets the boiler supply water temperature setpoint when heating demand is low. Heating demand is determined by the temperature difference between supply and return water.

However, regardless of the load, this setpoint is not allowed to drop below 60°C. The efficiency of condensing boilers increases as loop temperatures drop and operating the boilers at higher temperatures does not take advantage of their higher efficiency.

```

//FINAL SET POINT BASED ON DELTA T ONLY (PANELS 100 FULL TO CALC AVG_VALVE)
BLR_HWST_SP = Limit ((BLR_HWL_DELTA_T_MODIFIER + BLR_HWST_MIN), 60, 83)
//ENABLE/DISABLE BOILERS BASED ON OAT
    
```

10400.AV29 = 60 °C

We observed the boilers operating in several conditions, with outdoor temperatures down to 7°C, and the setpoint did not rise above 60°C. We were not able to observe the boilers in any conditions in which the building required higher heating water temperatures.

### 5.2.2 Measure Description

We recommend updating the boiler supply temperature reset logic to use trim and respond logic based on zone feedback (i.e., the position of heating valves required to maintain the room temperature). This will reduce the boiler temperature to the lowest that keeps all zones comfortable, operate the boilers at highest possible efficiency, and reduce distribution losses.

The algorithm also identifies which zones require the highest loop temperature. There may be issues with equipment in these zones, for example blocked or passing heating coil valves (see ECM 5.1 and ECM 5.6) which should be corrected first, or it may just be due to the selection of coils/equipment in these zones.

We also recommend enabling long term trending for the heating system, including water supply and return temperatures, and heating valve positions and room temperatures, will provide important insights for future electrification of the heating system.

### 5.2.3 Measure Implementation Update

[Provide confirmation details **AFTER** the measure is implemented and verified]

### 5.3 Measure 3: AHUs Running Overnight

#### 5.3.1 Description of Finding

HV-1, HV-2, and AC-1 are programmed to operate for normal operation whenever the variable CLASS\_SCH\_BV is ON. This variable is always on and appears to have no Control Source (e.g., schedule). Therefore, these AHUs operate continuously in occupied mode, causing unnecessary fan energy use and gas consumption (for ventilation heating).

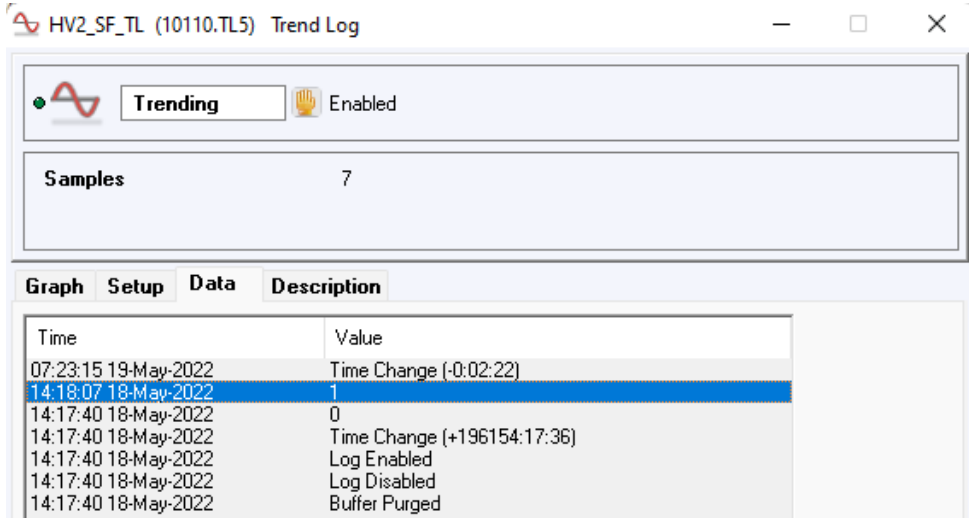

Figure 11: HV-2 supply fan trend show it turned on for the last several months.

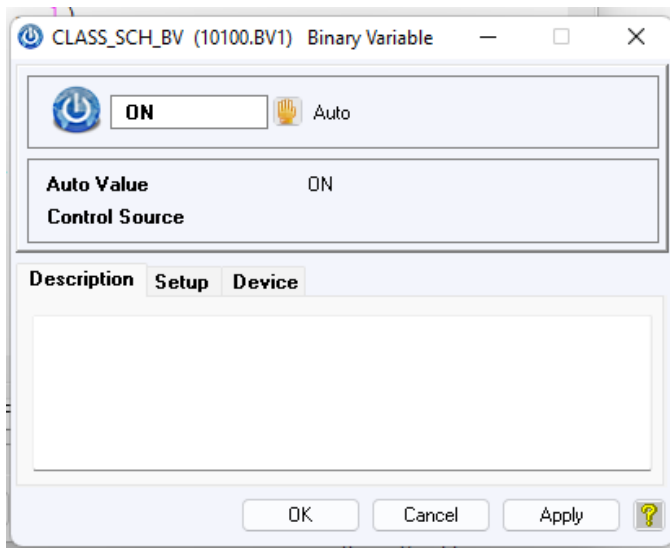

Figure 12: CLASS\_SCH\_BV has no "Control Source" program changing it

```

5 ● HV1_LOW_RT = Min (RMN122_RT_AV, RMN130_RT_AV)
6 ● HV1_AVG_RT = Average (RMN122_RT_AV, RMN130_RT_AV)
7 ● HV1_OCC = Max (CLASS_SCH_BV, HV1_OS_BV)
8 ●
9 ● End Do
10 ●
--
51 ● //SYSTEM START-UP MODE
52 ● If (HV1_OCC = On) Or (BUILDING_FLUSH_BV = On) Or (Enhanced_Air_Ad
53 ● HV1_RFC = On
54 ● HV1_NSB_BV = Off
55 ● Else

```

10106.BV21 = ON

Figure 13: HV-1 is enabled in occupied mode due to the value of CLASS\_SCH\_BV

```

6 ● HV2_LOW_RT = Min (RMN206_RT_AV, RMN208_RT_AV, RMN
7 ● HV2_AVG_RT = Average (RMN206_RT_AV, RMN208_RT_AV,
8 ● HV2_OCC = Max (CLASS_SCH_BV, HV2_OS_BV)
9 ● End Do
10 ●

```

Figure 14: HV-2 enabled by the value of CLASS\_SCH\_BV

```

4 ● AC1_AVG_RT = Average (RMN214_RT_AV, RMN215_RT_AV)
5 ● AC1_OCC = Max (CLASS_SCH_BV, AC1_OS_BV)
6 ●

```

Figure 15: AC-1 enabled by the value of CLASS\_SCH\_BV

### 5.3.2 Measure Description

The occupancy mode logic for HV-1, HV-2 and AC-2 should be updated to refer to the main building operating schedule (KSS\_CLASSROOM\_SCH)

### 5.3.3 Measure Implementation Update

[Provide confirmation details **AFTER** the measure is implemented and verified]

## 5.4 Measure 4: Weekly schedule

### 5.4.1 Description of Finding

Kwalikum Secondary’s main operating schedule (KSS\_CLASSROOM\_SCH) starts at 4am Monday to Wednesday, and 7am Thursday and Friday. The later start on Thursday and Friday indicates that the school typically warms up in time even with a later start.

In addition, the schedule includes one hour of occupancy from 6-7pm Monday to Friday. It is unclear what this is for.

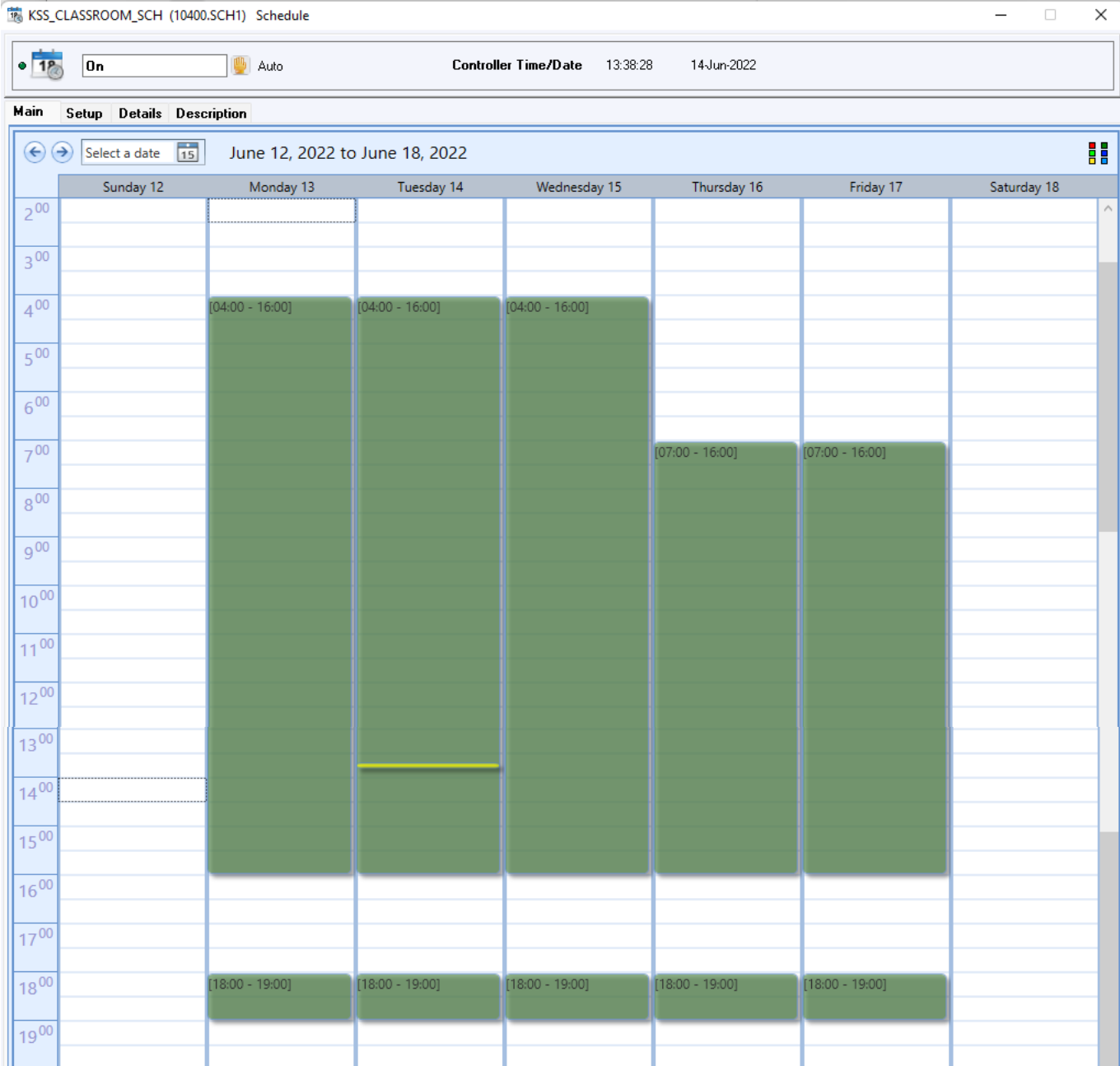

Figure 16: Main operating schedule

### 5.4.2 Measure Description

Program the DDC to adjust start times based on outdoor air temperature and room temperatures, since it takes more time to warm up the building on a cold morning than on a warmer day when the building has retained most of the heat from the previous day. This is commonly known as “optimal start”. The start time should be calculated separately for each air handler, since they have different occupancy times

### 5.4.3 Measure Implementation Update

[Provide confirmation details **AFTER** the measure is implemented and verified]

## 5.5 Measure 5: Night Setback

### 5.5.1 Description of Finding

Lowering the building temperature at night, commonly known as “night setback”, reduces the heating required. The school DDC already has logic to do this, but the night setback temperature is between 19°C and 20°C for most zones per Table 5, which is too high to provide any significant savings.

Table 5: Current night setback temperatures

Unit	Night setback
HV-1, HV-2, HV-3	19.9°C
HV-4 to HV-7	19°C
HV-8	14°C
AC-1, AC-2	19.9°C
AC-3, AC-4, AC-5	19°C
Radiators	19°C
Fan coils	No setback

Some units follow the global night setback variable. This has been overridden to to 19°C.

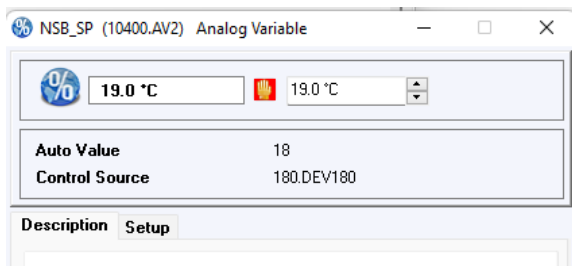

The night setbacks for other units are calculated using various equations. In some cases, the logic refers to undefined values which may result in unpredictable results.

```

56   HV1_NSB_BV = Switch ( HV1_NSB_BV, HV1_LOW_RT, NSB_SP_AV - 1, NSB_SP_AV)
57   HV1_RFC = HV1_NSB_BV
58 End If
59
10  RMN107_VAR = 10105.DA11207
11  NSB_SP_AV = (RMN107_SP_AV - RMN106_RT_AV) * 10100.CO6 / 100 + RMN106_RT_AV
12
13  COMMON_SP_AV = 10107.Temperature
14  RMN106_RT_AV = '10107.Day Setpoint'
    
```

Figure 17: NSB calculations for HV3 refers to undefined values

### 5.5.2 Measure Description

Change the night setback for all zones and equipment to 15°C. Link all zones to the global night setback temperature setpoint.

Where available, enable terminal units including radiators and fan coils before AHUs during unoccupied periods. This will reduce AHU operating hours, saving fan energy use while still heating the zones.

### 5.5.3 Measure Implementation Update

[Provide confirmation details **AFTER** the measure is implemented and verified]

## 5.6 Measure 6: Reheat Coils Passing or Blocked

### 5.6.1 Description of Finding

Several reheat coils were found to be operating incorrectly. Some appear to be blocked: they did not provide any heating even when commanded open. This indicates an issue with the control valve sticking closed, the coil obstructing water flow, or a lack of air flow through the coil.

Other coil control valves appear to be passing: the coils provided heat when the control valves were commanded closed. This indicates an issue with the control valve mechanism, wiring, or programming.

Both issues cause comfort issues in the space served by the coil. They can cause the associated air handler to raise or lower supply air temperature which can affect comfort in other. Both issues can increase energy use.

A summary of problem reheat coils is provided in Table 6.

Table 6: Reheat coil issues

Air handler	Blocked Coils	Passing Coils
HV-1	RM129, RM125, RM126	
HV-2	RM113, RM115, RM204, RM207	RM208, RM210, RM114
HV-7	RM220, RM225	
AC-1		RM214
AC-2	RM101, RM104, RM106, RM134, RM137, RM102 (also passing?)	RM102
AC-3	RM215	RM211E, RM211W
AC-4	RM101, RM105, RM114, RM204A, RM257, RM258	RM103C, RM104,
AC-5	RM251, RM255	RM208

Examples of issues are shown in Figure 18 and Figure 19.



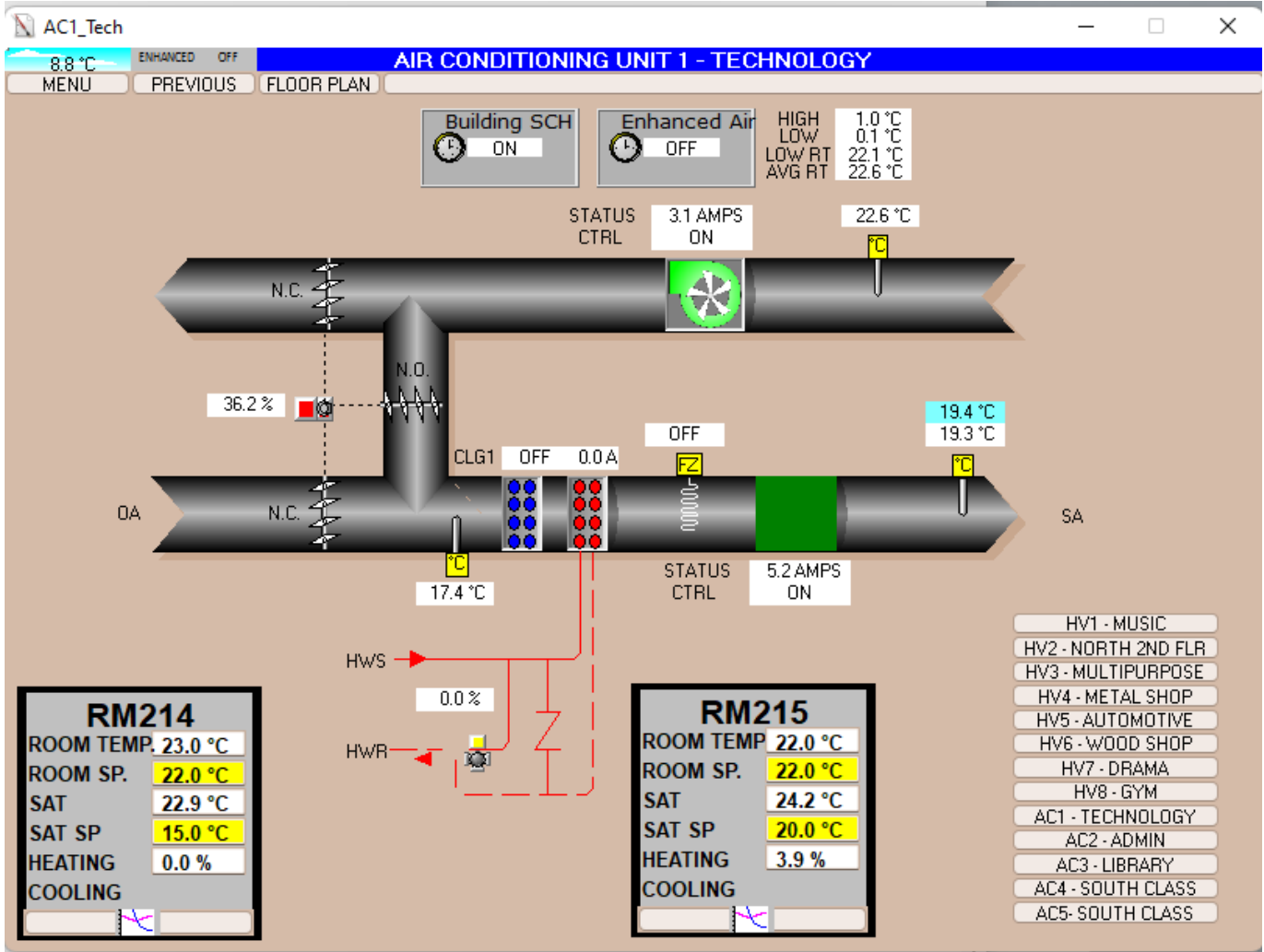

Figure 18: RM214 supply air temperature is 3.5°C hotter than provided from AC-1, even with reheat coil control valve closed.

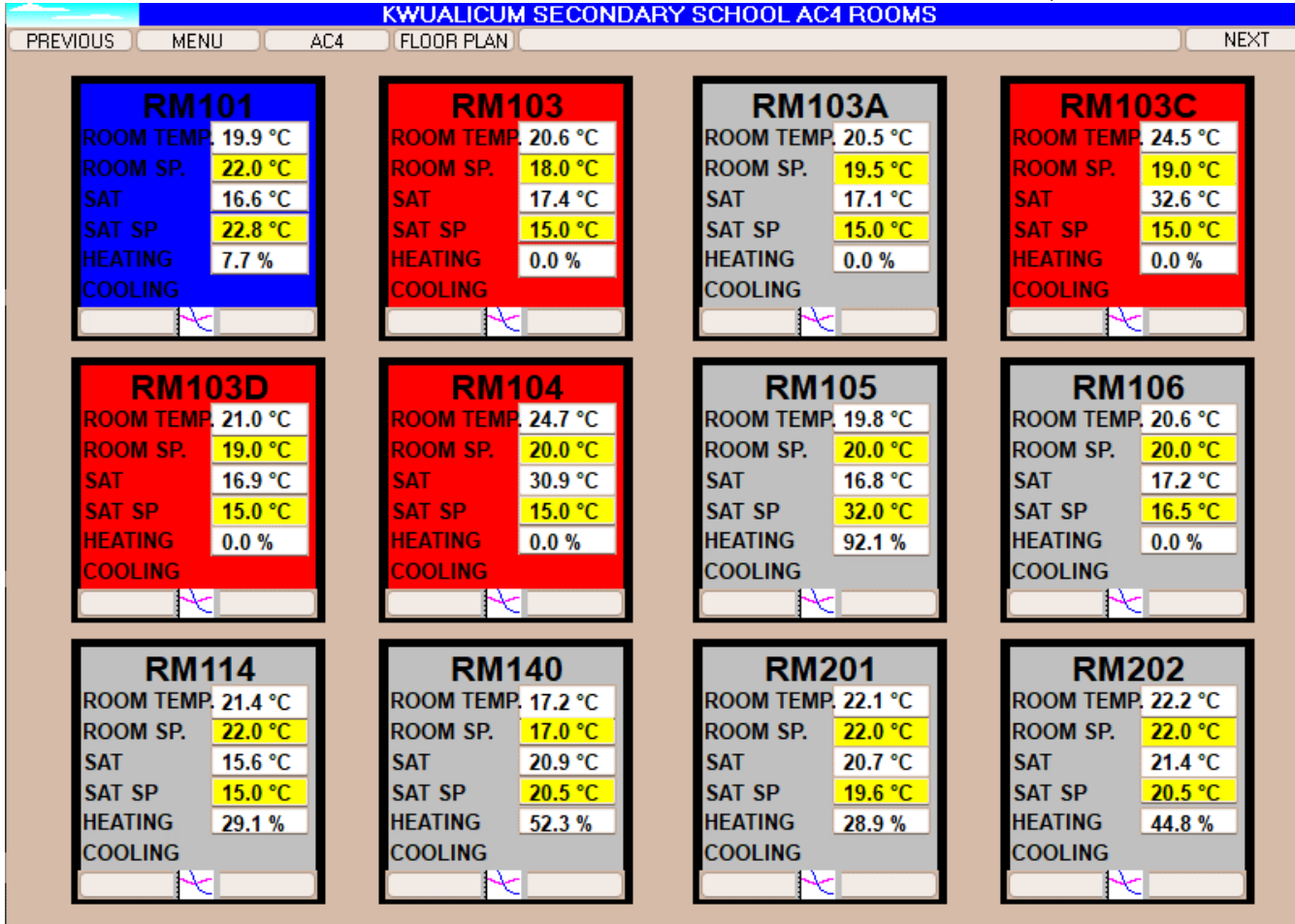

Figure 19: AC-4 reheat coils. The supply air from the air handler was 17.2°C. RM103C and RM104 have much higher supply air temperature with no reheat. RM105 has no heat increase with its heating coil control valve 92% open.

### 5.6.2 Measure Description

Each problem reheat coil should be diagnosed and repaired. This may include repairing or replacing the valve, control components, or even the coil itself. Our costing estimates that approximately half of the identified coils need new valves, and that the rest of the issues can be resolved with simple repairs (recalibrating actuators, cleaning coils, etc.). If any reheat coils are replaced, they should be sized for 45°C or less entering heating water at design conditions to accommodate future efficiency projects.

### 5.6.3 Measure Implementation Update

[Provide confirmation details **AFTER** the measure is implemented and verified]

## 5.7 Measure 7: HV-7 and HV-8 Outdoor Dampers

### 5.7.1 Description of Finding

#### HV-7

The control logic for HV-7 fully closes the outdoor air damper because Enhanced\_Air\_Mode is commanded off. This stops HV-7 from cooling its zones with outdoor air. Furthermore, the lack of outdoor air ventilation reduces indoor air quality.

```

74 ●
75 ●      If HV7_NSB_BV On Or Enhanced Air Mode = Off Then
76 ●          HV7_MAD_AV = 0
77 ●      End If
78 ●      End If
    
```

10219.BV28 = OFF

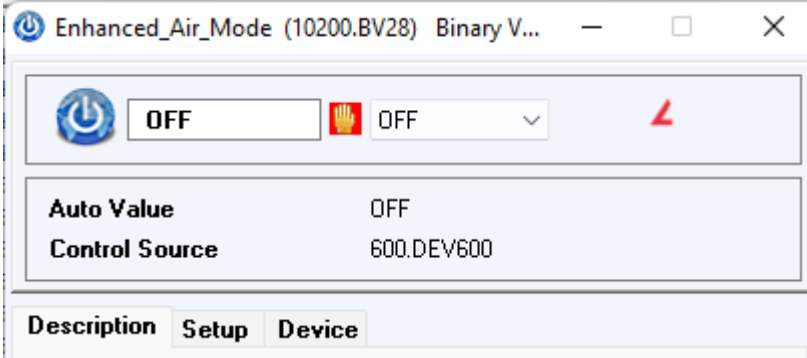

Figure 20: HV-7 MAD closes since Enhanced\_Air\_Mode is off

### HV-8

The HV-8 supply fan feedback sensor returns -1.4%, which is interpreted as the fan has failed. The control logic thus activates HV-8’s “shutdown” mode. This keeps the mixed air dampers closed, leading to indoor air quality and comfort issues.

```

// ●      // DAMPER CONTROL
78 ●      If HV8_SF_SPD_S > 25 Then
79 ●          DoEvery 1 10402.AI1 = -1.4 %
80 ●          HV8_MAD_RAMP = Limit (HV8_MAD_RAMP + (HV8_RAT - (GYM_DAY_SP - 2)), 0, 100)

105 Else
106 ●          //SHUT-DOWN MODE
107 ●          HV8_MAD_AV = 0
108 ●          HV8_MAD_RAMP = 0
109 ●          HV8_HCV_AV = 100 - HV8_MAD_LL_CO
110 ●      End If
    
```

### 5.7.2 Measure Description

Remove the reference to Enhanced\_Air\_Mode in the HV-7 logic mixed air damper logic. Confirm if the HV-8 feedback sensor matches actual fan status and replace if necessary. There are no energy savings associated with this measure.

### 5.7.3 Measure Implementation Update

[Provide confirmation details **AFTER** the measure is implemented and verified]

## 5.8 Measure 8: Broken Sensors

### 5.8.1 Description of Finding

The Corridor 237 room temperature sensor reads -49.9°C. This causes the associated convective heater to operate continuously.



```

7
8 RT_237_AV = '10222.Input 2 '
9 RT_237_VAR = RT_237_AV - 10200.COMMON_SP_AV
10 '10222.Output3 - REHOTE (BIN DIR)' = Switch ( '10222.Output3 - REMOTE (BIN DIR)', RT_237_AV, 10200.COMMON_SP_AV - 1, 10200.COMMON_SP_AV)
11
12
13
14
15
16
17
18
19
20
21
22
23
24
25
26
27
28
29
30
31
32
33
34
35
36
37
38
39
40
41
42
43
44
45
46
47
48
49
50
51
52
53
54
55
56
57
58
59
60
61
62
63
64
65
66
67
68
69
70
71
72
73
74
75
76
77
78
79
80
81
82
83
84
85
86
87
88
89
90
91
92
93
94
95
96
97
98
99
100
101
102
103
104
105
106
107
108
109
110
111
112
113
114
115
116
117
118
119
120
121
122
123
124
125
126
127
128
129
130
131
132
133
134
135
136
137
138
139
140
141
142
143
144
145
146
147
148
149
150
151
152
153
154
155
156
157
158
159
160
161
162
163
164
165
166
167
168
169
170
171
172
173
174
175
176
177
178
179
180
181
182
183
184
185
186
187
188
189
190
191
192
193
194
195
196
197
198
199
200
201
202
203
204
205
206
207
208
209
210
211
212
213
214
215
216
217
218
219
220
221
222
223
224
225
226
227
228
229
230
231
232
233
234
235
236
237
238
239
240
241
242
243
244
245
246
247
248
249
250
251
252
253
254
255
256
257
258
259
260
261
262
263
264
265
266
267
268
269
270
271
272
273
274
275
276
277
278
279
280
281
282
283
284
285
286
287
288
289
290
291
292
293
294
295
296
297
298
299
300
301
302
303
304
305
306
307
308
309
310
311
312
313
314
315
316
317
318
319
320
321
322
323
324
325
326
327
328
329
330
331
332
333
334
335
336
337
338
339
340
341
342
343
344
345
346
347
348
349
350
351
352
353
354
355
356
357
358
359
360
361
362
363
364
365
366
367
368
369
370
371
372
373
374
375
376
377
378
379
380
381
382
383
384
385
386
387
388
389
390
391
392
393
394
395
396
397
398
399
400
401
402
403
404
405
406
407
408
409
410
411
412
413
414
415
416
417
418
419
420
421
422
423
424
425
426
427
428
429
430
431
432
433
434
435
436
437
438
439
440
441
442
443
444
445
446
447
448
449
450
451
452
453
454
455
456
457
458
459
460
461
462
463
464
465
466
467
468
469
470
471
472
473
474
475
476
477
478
479
480
481
482
483
484
485
486
487
488
489
490
491
492
493
494
495
496
497
498
499
500
501
502
503
504
505
506
507
508
509
510
511
512
513
514
515
516
517
518
519
520
521
522
523
524
525
526
527
528
529
530
531
532
533
534
535
536
537
538
539
540
541
542
543
544
545
546
547
548
549
550
551
552
553
554
555
556
557
558
559
560
561
562
563
564
565
566
567
568
569
570
571
572
573
574
575
576
577
578
579
580
581
582
583
584
585
586
587
588
589
590
591
592
593
594
595
596
597
598
599
600
601
602
603
604
605
606
607
608
609
610
611
612
613
614
615
616
617
618
619
620
621
622
623
624
625
626
627
628
629
630
631
632
633
634
635
636
637
638
639
640
641
642
643
644
645
646
647
648
649
650
651
652
653
654
655
656
657
658
659
660
661
662
663
664
665
666
667
668
669
670
671
672
673
674
675
676
677
678
679
680
681
682
683
684
685
686
687
688
689
690
691
692
693
694
695
696
697
698
699
700
701
702
703
704
705
706
707
708
709
710
711
712
713
714
715
716
717
718
719
720
721
722
723
724
725
726
727
728
729
730
731
732
733
734
735
736
737
738
739
740
741
742
743
744
745
746
747
748
749
750
751
752
753
754
755
756
757
758
759
760
761
762
763
764
765
766
767
768
769
770
771
772
773
774
775
776
777
778
779
780
781
782
783
784
785
786
787
788
789
790
791
792
793
794
795
796
797
798
799
800
801
802
803
804
805
806
807
808
809
810
811
812
813
814
815
816
817
818
819
820
821
822
823
824
825
826
827
828
829
830
831
832
833
834
835
836
837
838
839
840
841
842
843
844
845
846
847
848
849
850
851
852
853
854
855
856
857
858
859
860
861
862
863
864
865
866
867
868
869
870
871
872
873
874
875
876
877
878
879
880
881
882
883
884
885
886
887
888
889
890
891
892
893
894
895
896
897
898
899
900
901
902
903
904
905
906
907
908
909
910
911
912
913
914
915
916
917
918
919
920
921
922
923
924
925
926
927
928
929
930
931
932
933
934
935
936
937
938
939
940
941
942
943
944
945
946
947
948
949
950
951
952
953
954
955
956
957
958
959
960
961
962
963
964
965
966
967
968
969
970
971
972
973
974
975
976
977
978
979
980
981
982
983
984
985
986
987
988
989
990
991
992
993
994
995
996
997
998
999
1000

```

North block Sprinklers 142B room temperature sensor is reads -50.7°C, causing the radiator to be enabled continuously.

```

4 RM142_VAR = RT_142_AV - 10400.COMMON_SP
5 10119.RAD~142B = Switch ( 10119.RAD~142B, RT_142_AV, 10400.COMMON_SP - 1, - 10400.COMMON_SP)
6
7 End Do

```

The boys change room (Room 129) room temperature sensor reads -50.0°C, causing the reheat coil serving the space to stay at 100%, heating continuously.

```

HV8_ROOMS_PG (10301.PG3) Program
1 RM129_RT_AV = 129 RT
2 RM129_SP_AV = 103(10301.AI102 = -50 °C ?)_AV
3 RM129_VAR = RM129_RT_AV - RM129_SP_AV
4
5
6
7
8
9
10
11
12
13
14
15
16
17
18
19
20
21
22
23
24
25
26
27
28
29
30
31
32
33
34
35
36
37
38
39
40
41
42
43
44
45
46
47
48
49
50
51
52
53
54
55
56
57
58
59
60
61
62
63
64
65
66
67
68
69
70
71
72
73
74
75
76
77
78
79
80
81
82
83
84
85
86
87
88
89
90
91
92
93
94
95
96
97
98
99
100
101
102
103
104
105
106
107
108
109
110
111
112
113
114
115
116
117
118
119
120
121
122
123
124
125
126
127
128
129
130
131
132
133
134
135
136
137
138
139
140
141
142
143
144
145
146
147
148
149
150
151
152
153
154
155
156
157
158
159
160
161
162
163
164
165
166
167
168
169
170
171
172
173
174
175
176
177
178
179
180
181
182
183
184
185
186
187
188
189
190
191
192
193
194
195
196
197
198
199
200
201
202
203
204
205
206
207
208
209
210
211
212
213
214
215
216
217
218
219
220
221
222
223
224
225
226
227
228
229
230
231
232
233
234
235
236
237
238
239
240
241
242
243
244
245
246
247
248
249
250
251
252
253
254
255
256
257
258
259
260
261
262
263
264
265
266
267
268
269
270
271
272
273
274
275
276
277
278
279
280
281
282
283
284
285
286
287
288
289
290
291
292
293
294
295
296
297
298
299
300
301
302
303
304
305
306
307
308
309
310
311
312
313
314
315
316
317
318
319
320
321
322
323
324
325
326
327
328
329
330
331
332
333
334
335
336
337
338
339
340
341
342
343
344
345
346
347
348
349
350
351
352
353
354
355
356
357
358
359
360
361
362
363
364
365
366
367
368
369
370
371
372
373
374
375
376
377
378
379
380
381
382
383
384
385
386
387
388
389
390
391
392
393
394
395
396
397
398
399
400
401
402
403
404
405
406
407
408
409
410
411
412
413
414
415
416
417
418
419
420
421
422
423
424
425
426
427
428
429
430
431
432
433
434
435
436
437
438
439
440
441
442
443
444
445
446
447
448
449
450
451
452
453
454
455
456
457
458
459
460
461
462
463
464
465
466
467
468
469
470
471
472
473
474
475
476
477
478
479
480
481
482
483
484
485
486
487
488
489
490
491
492
493
494
495
496
497
498
499
500
501
502
503
504
505
506
507
508
509
510
511
512
513
514
515
516
517
518
519
520
521
522
523
524
525
526
527
528
529
530
531
532
533
534
535
536
537
538
539
540
541
542
543
544
545
546
547
548
549
550
551
552
553
554
555
556
557
558
559
560
561
562
563
564
565
566
567
568
569
570
571
572
573
574
575
576
577
578
579
580
581
582
583
584
585
586
587
588
589
590
591
592
593
594
595
596
597
598
599
600
601
602
603
604
605
606
607
608
609
610
611
612
613
614
615
616
617
618
619
620
621
622
623
624
625
626
627
628
629
630
631
632
633
634
635
636
637
638
639
640
641
642
643
644
645
646
647
648
649
650
651
652
653
654
655
656
657
658
659
660
661
662
663
664
665
666
667
668
669
670
671
672
673
674
675
676
677
678
679
680
681
682
683
684
685
686
687
688
689
690
691
692
693
694
695
696
697
698
699
700
701
702
703
704
705
706
707
708
709
710
711
712
713
714
715
716
717
718
719
720
721
722
723
724
725
726
727
728
729
730
731
732
733
734
735
736
737
738
739
740
741
742
743
744
745
746
747
748
749
750
751
752
753
754
755
756
757
758
759
760
761
762
763
764
765
766
767
768
769
770
771
772
773
774
775
776
777
778
779
780
781
782
783
784
785
786
787
788
789
790
791
792
793
794
795
796
797
798
799
800
801
802
803
804
805
806
807
808
809
810
811
812
813
814
815
816
817
818
819
820
821
822
823
824
825
826
827
828
829
830
831
832
833
834
835
836
837
838
839
840
841
842
843
844
845
846
847
848
849
850
851
852
853
854
855
856
857
858
859
860
861
862
863
864
865
866
867
868
869
870
871
872
873
874
875
876
877
878
879
880
881
882
883
884
885
886
887
888
889
890
891
892
893
894
895
896
897
898
899
900
901
902
903
904
905
906
907
908
909
910
911
912
913
914
915
916
917
918
919
920
921
922
923
924
925
926
927
928
929
930
931
932
933
934
935
936
937
938
939
940
941
942
943
944
945
946
947
948
949
950
951
952
953
954
955
956
957
958
959
960
961
962
963
964
965
966
967
968
969
970
971
972
973
974
975
976
977
978
979
980
981
982
983
984
985
986
987
988
989
990
991
992
993
994
995
996
997
998
999
1000

```

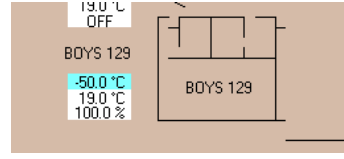

Operating heaters continuously overheats spaces, reducing comfort and wasting energy.

### 5.8.2 Measure Description

Ensure the room temperature sensors are properly connected to the DDC. Replace the sensors where broken.

### 5.8.3 Measure Implementation Update

[Provide confirmation details **AFTER** the measure is implemented and verified]

## 6.0 Measures to be considered for Future Implementation

This section provides an overview of each measure (that was identified but **was not selected** as part of this C. Op. project, but maybe considered for future implementation), recommendations for implementation, and the most suitable method for providing evidence of implementation. See Appendix A - Investigation Phase Summary Table for more details.

### 6.1 Measure 9: Four Dual-Fuel Roof Top Units

Four of Kwalikum Secondary's air-conditioning rooftop units (AC-1, AC-2, AC-3 and AC-5)<sup>1</sup> are 20 years old and nearing the end of typical useful service life. Their DX cooling systems use R-22 refrigerant, which is obsolete.

When the units need to be replaced<sup>2</sup>, we propose selecting dual-fuel rooftop units equipped with reversible air source heat pumps in place of the existing DX systems. Air source heat pumps provide efficient low-emission heating as well as cooling. The retrofit units would retain heating coils for supplementary heating from the central boilers plant. The heating coils should be compatible with low entering heating water temperature (<50°C at design conditions).

Measure costs assume all four units are replaced.

### 6.2 Measure 10: Central Air Source Heat Pump

The gas-fired heating plant can be supplemented with an air source heat pump. This can achieve significant gas (and emissions) reduction, even with a unit sized for only part of the full heating load, since it can often meet all heating requirements at mild temperatures and supplement the existing gas boilers during colder periods.

The heating loop is currently operated above 60°C heating water supply temperature continuously. This is too high to be served by commercially available air source heat pumps. However, analysis of the DDC indicates that it would be possible to reduce the loop temperature, while providing adequate heating, at least in milder conditions.

We recommend a feasibility study during the next heating season, after implementing logic to reduce the loop temperature (see ECM 5.2). The investigation will identify the required upgrades to the distribution equipment (mainly the heating coils) required to operate the building at loop supply temperatures at 50°C for a significant part of the heating season. This equipment can be upgraded as part of regular replacement cycle, or on a more aggressive schedule. Note that any reduction in loop temperature will provide immediate gas (and emissions) savings as the system efficiency is improved. Heat pump capacity can be added incrementally, as the system is adapted to operate at low loop temperatures at colder temperatures.

Reversible heat pump can also provide chilled water, and it should be explored whether this is a practical and economical method for providing cooling in any of the existing units. As an example, we've explored cost and energy savings from replacing the aging condensing unit in AC-4 with a 60T reversible air-to-water heat pump. During heating season, the unit can produce hot water for the heating loop. During cooling season, it can produce chilled water piped to a new cooling coil in AC-4. The calculated savings assume the heating loop can be operated at temperatures of 50°C (or below) when the outdoor temperature is 6°C or warmer.

---

<sup>1</sup> A fifth air conditioning unit, AC-4, is located inside in the mechanical penthouse and likely has a different replacement schedule and options. The condensing unit for AC-4 is due for replacement and has been considered in ECM 6.2.

<sup>2</sup> If the units are in good condition, an alternative strategy is to replace only the DX coils and serve these with external VRF units which provide both heating and cooling.

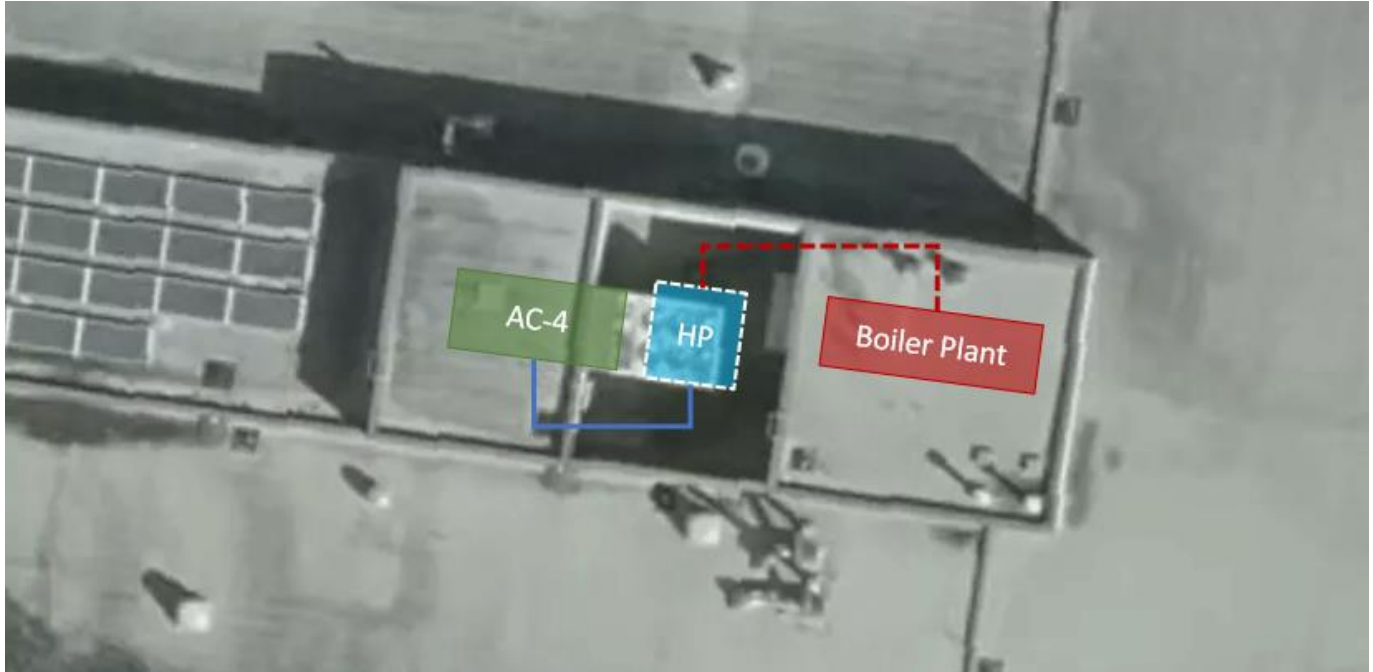

Figure 21: Possible location for an air-source heat pump serving both AC-4 and the central heating loop

## 7.0 Next Steps – Implementation Phase and Completion Phase

### 7.1 Implementation Phase

To continue in the program, the owner is responsible for implementing the selected bundle of measures that pay back in two years or less. Using the *Recommissioning Report* for implementation allows flexibility in how the selected measures are implemented. Options include: utilize in-house building staff, hire the C.Op Provider to implement or provide technical assistance, contract with outside service contractors, or any combination of the above.

### 7.2 Completion Phase

C.Op Service provider will follow up after implementation of the selected measures and **update** this *Recommissioning report and Recommissioning Workbook*.

The updated report for the implemented measures includes but not limited to: date of completion of each measure, new or improved sequences of operation, the energy savings impact of the measures, the requirements for ongoing maintenance and monitoring of the measures, and contact information for the service provider, in house staff, and contractors responsible for the implementation. When feasible, verification data should include trends or functional test results, though other methods, such as copies of invoices, site visit reports, and before/after photos, may be acceptable.

The C.Op Service Provider will conduct an in-house (teleconference) session for the Applicant and the appropriate building operations personnel covering the new documentation, measures that were implemented, and requirements for ongoing maintenance and monitoring. Document the attendance of the building operations staff.



We're working together to help B.C. save energy.



The *updated Recommissioning Workbook* and *updated Recommissioning Report* will be submitted to the owner and the program for review. See Appendix B: Completion Phase Summary Table for more details on implemented measures.

## Appendix A: Investigation Phase Summary Table

Investigation Phase Summary				Investigation Phase							
ECM #	Measure Title	Measure History	Include cost	Energy Savings			Cost Savings	Financial		Est. GHG Reduction	Enter "x" if DESELECT for implementation
				Demand (kW)	Electrical (kWh/yr)	Fuel (GJ)	Total (\$/yr)	Estimated Measure Cost (\$)	Simple Payback (yrs)	tonnes CO2e/yr	
ECM-1	Air Handler Control Valves Passing	New	1	-	-	1,164	\$ 14,116	\$ 2,900	0.2	58.1	
ECM-2	Boiler Setpoint Optimization	New	1	-	-	182	\$ 2,209	\$ 6,000	2.7	9.1	
ECM-3	AHUs running overnight	New	1	-	147,432	311	\$ 18,272	\$ 400	0.0	17.1	
ECM-4	Weekly schedule	New	1	-	46,876	308	\$ 8,351	\$ 600	0.1	15.9	
ECM-5	Night Setback	New	1	-	-	709	\$ 8,593	\$ 700	0.1	35.4	
ECM-6	Reheat valves and coils	New	1	-	-	732	\$ 8,878	\$ 24,300	2.7	36.5	
ECM-7	HV-7 and HV-8 Air Dampers	New	1	-	-	-	\$ -	\$ 800	#DIV/0!	-	
ECM-8	Broken sensors	New	1	-	-	-	\$ -	\$ 1,400	#DIV/0!	-	
ECM-9	Four ASHP Hot Water RTUs	New	1	-	21,091	253	\$ 993	\$ 563,600	567.4	12.4	x
ECM-10	Central Air Source Heat Pump	New	1	-	96,545	1,119	\$ 4,066	\$ 427,500	105.1	54.8	x
TOTAL (Previous, still working):				-	-	-	\$ -	n/a	n/a	-	
TOTAL (All potential measures for Implementation):				-	76,672	4,779	\$ 65,480	\$ 1,028,200	15.7	239.2	
TOTAL (Selected measures only):				-	194,307	3,407	\$ 60,420	\$ 37,100	0.6	172.0	
				Implementation cap @\$0.25/ft2				\$	26,302		



## Appendix B: Completion Phase Summary Table

[Paste image of Completion Summary Table from the RCx Workbook AFTER Implementation]

## Appendix C: Sample Training Outline

[Completion Report AFTER Implementation]

The Commissioning Provider (C.Op Provider) may customize the outline for the training and developing the training materials. Before preparing the training outline and materials, the C.Op Provider should assess the related level of knowledge of the building operators, to set up the training accordingly. For reference, the Program provides the following sample outline for the training:

- Background on the energy use of this particular building
  - Present Energy Utilization Index
  - Describe Operating Schedules and Owner's operating requirements
- RCx investigation process used in this building
  - Describe the methods used to identify problems and deficiencies
  - Review the RCx Workbook
- Implementation process in this building
  - Describe the measures that were implemented and by whom
  - Walk around the building to look at any physical changes or step through the new control sequences at the operator workstation
  - Provide as many details about implementation as necessary to describe what was done
  - Describe improved performance that these measures will create (show trends if available)
- O&M requirements
  - Describe the O&M requirements needed to keep these improvements working
  - Describe how the staff can be aware of energy efficiency opportunities and begin looking for additional savings potential

The C.Op Provider should follow the outline to prepare materials, as necessary, to hand out at the training session.



## Appendix D: Training Completion Form

Project ID
------------

### Facility Information

Company Name	Building Name(s)
Facility Address	City Province

### Training Details

Location	Date
Commissioning Provider/Trainer	

### Materials Attached

<input type="checkbox"/> Agenda
<input type="checkbox"/> Materials used for training
<input type="checkbox"/> List of individuals who attended

### COMMISSIONING PROVIDER SIGNATURE

By signing this Training Completion Form, I verify that this training took place with the listed attendees.	
Commissioning Provider (print name):	
Signature:	Date:

**FACSIMILE/SCANNED SIGNATURES:** Facsimile transmission of any signed original document, and the retransmission of any signed facsimile transmission, shall be the same as delivery of the original signed document. Scanned original documents transmitted to BC Hydro as an attachment via electronic mail shall be the same as delivery of the original signed document. At the request of BC Hydro, C.Op Provider shall confirm documents with a facsimile transmitted signature or a scanned signature by providing an original document.

Targeted Documentation

O & M Manual

O & M Manual updated <input type="checkbox"/>	Describe updates below and attach copies of new or amended portions
O & M Manual not updated <input type="checkbox"/>	Province reasons below
Building has no O & M Manual <input type="checkbox"/>	

Building Plans (“as-builts”)

Building Plans updated <input type="checkbox"/>	Describe below
Wiring diagrams updated <input type="checkbox"/>	Describe below
No plans or diagrams updated <input type="checkbox"/>	Describe below

EMS Programming

New sequences of operation on file <input type="checkbox"/>	Specify location of file and attach copy
Printed screenshots on file <input type="checkbox"/>	Specify location of file and attach copy

Equipment Manuals

Manuals for new equipment are on file <input type="checkbox"/>	Describe below (attach copy if applicable)
--	--

We're working together to help B.C. save energy.



